

kortho

MANUAL

GraphicJet X-series

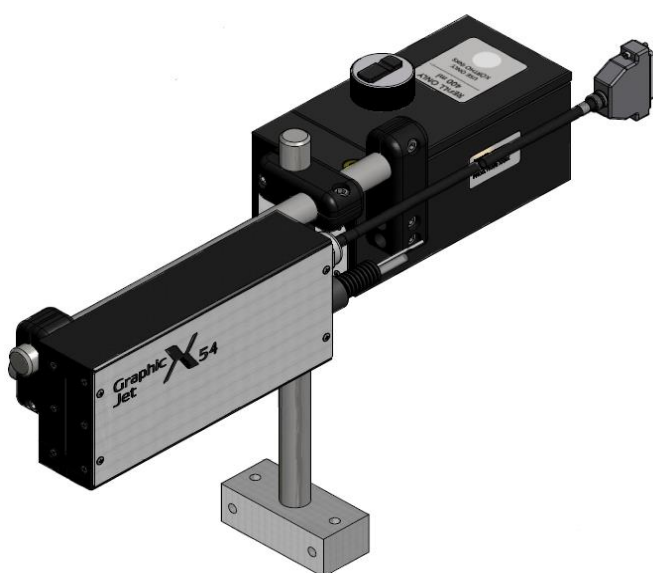
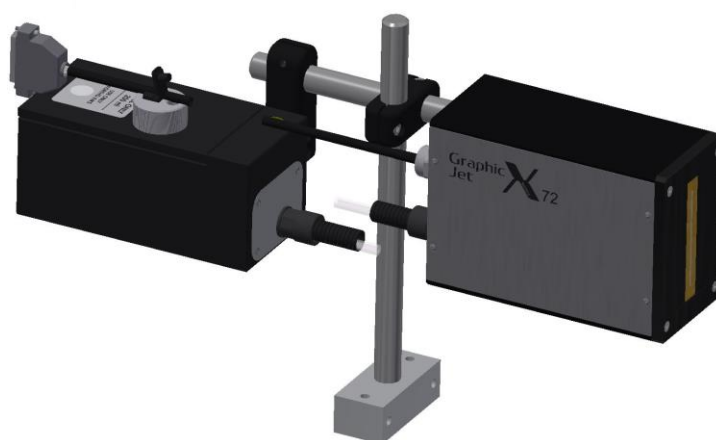

bv korthofah

P.O. box: 3040
2220 CA, Katwijk
The Netherlands

Tel: +31 71 40 60 480
Fax: +31 71 40 32 807
E-mail: export@kortho.nl
Internet: www.kortho.com, www.kortho.eu

In light of continuous development and improvement, Korthofah BV reserves the right to modify the specifications without prior notice. The figures printed in this manual may slightly differ from the Kortho GraphicJet. Information in this document is subject to change without notice.

No part of this document may be reproduced or transmitted in any form or by any means, electronic or mechanical, without the written permission of Korthofah BV.

Document date: 16/08/2019
Manual: H550 AE KGJ TSC20 EN 006.doc
Number of pages: 236

The basis for this manual is:

Series: KGJ X-series
Production year: 2016 - 2018
Original language: English

Standard models: KGJ X18 / X18+ / X18si / X54 / X72 series + TsC20-X / TsC20-X duo
QiC Control version: V1.0-06032018a

Copyright © 2019 **bv korthofah**
All Rights Reserved



The **kortho** logo and the **bv Korthofah** logo are trademarks of Korthofah BV. All other brand and product names in this manual are the trademarks or registered trademarks of their respective holders.

Printed in the EC 2019

■ Preface

Welcome to the GraphicJet X-series manual.

Read the manual before you start and read it carefully. This will avoid unnecessary problems and loss of performance.

This manual is meant for all personnel who are involved with the GraphicJet X-series, which includes the control units TsC20-X and TsC20-X duo and the coding units X18, X18+, X18si, X54 and X72. The purpose of this manual is to get familiar with the GraphicJet X-series. This involves operational, safety, transport & storage, installation, commissioning, fault diagnosis and maintenance instructions.

The general construction for the different types of coding units of the GraphicJet X-series is the same. Because of this there is no need to show pictures of each individual model. Functions which are typical for a particular control unit and/or coding unit will be marked by the type identification between brackets e.g. [TsC20-X duo] if the function is only available for the Control unit TsC20-X duo or [X72] if the function is not available for the coding unit X72.

All personnel must read the first four sections named INTRODUCTION, TECHNICAL DESCRIPTION, PRINT PROCESS DESCRIPTION and SAFETY. The other sections provide instructions or information for different aspects of the GraphicJet X-series.

Keep this manual on a sensible and safe place for future use.

Contact Korthofah BV or your local distributor if you have any questions.

Conventions in this manual:

- The GraphicJet X-series will be referred to as the printer.
- Any material the printer is used to print on is called substrate.
- The customer is the person or company who is the owner of the printer.
- Follow the instruction order as indicated when you carry out any of the procedures described.

Instruction format:

1. Instruction. Comment(s).
 - a. Sub-instruction. Comment(s).
 - b. Sub-instruction. Comment(s).
2. Instruction. Comment(s).

■ Symbols in this manual

In this manual, the following symbols are used:



WARNING:

This symbol indicates a potentially hazardous situation which, if instructions are not followed, could result in death or serious injury.



CAUTION:

This symbol indicates a potentially hazardous situation which, if instructions are not followed, may result in minor or moderate injury or damage to property.

The statements above are notes for your safety.



Beware:

A notice with useful information for the user in relation to the product. It attends the user to possible problems.

**Note:**

Gives the user suggestions and helps the work to be carried more rapidly.

■ Glossary

Bitmap:	A data file or structure. A set of bits that represents a graphic image, with each bit or group of bits corresponding to a pixel in the image.
Datum:	Drawing term for a fixed reference point from which measurements are taken.
Encoder:	This is a shaft encoder. It converts shaft rotations to pulses for accurate and precise measurements. The encoder generates pulses from which the control unit can extract the product speed information in order to match the print speed.
Host:	A machine or production system that handles the product or substrate and can be connected by an interface to the printer, e.g. a printer alarm to stop the machine.
Label:	A design file from which the printer generates the bitmap to print. This design file can contain a unique combination of text, numeric, date, time, barcode and/or graphical items.
Label memory:	Memory on the CPU board in which the labels, fonts and graphics can be stored. From this memory labels can be selected for printing (stored in the printlab memory).
Nozzle:	A narrow piece attached to the end of a tube so that the liquid that comes out can be directed in a particular way. In this case a small hole in a nozzle plate. The printhead comprises an array of channels containing ink. Ink droplets are ejected from a nozzle at the end of each channel as a result of pressure waves generated in the ink by deflection of the channel walls.
Nozzle plate:	A polymer film in which the nozzles are formed.
Pixel:	A pixel is the smallest portion of a bitmap. For a printer one pixel represents one dot.
Print:	The result of printing a label on a substrate.
Print memory:	Memory on the CPU board in which the label that one likes to print will be stored.
Print request:	A signal generated by a sensor or host machine. It is a trigger to start a print cycle.
Print cycle:	The moment from which the printer accepts a print request until the printer is ready to accept a new print request.
Product:	In this manual, the substrate the printer prints on, e.g. a box, package etc.
Sensor:	A product detection device connected to the control unit, usually a photocell.
Substrate:	This is the material of a product to print on, e.g. cardboard, wood, paper, and packaging foil.

■ Table of contents

▪	Preface.....	iii
▪	Symbols in this manual.....	iii
▪	Glossary.....	iv
▪	Table of contents	v

1 INTRODUCTION

1.1	Qualified personnel.....	1-1
1.2	Elementary personal protection.....	1-1
1.3	Intended Use	1-1
1.4	Specifications.....	1-2
1.4.1	Coding unit	1-2
1.4.2	Control unit	1-3
1.4.3	Ink.....	1-4
1.4.4	Label features.....	1-4
1.4.5	Life span	1-5
1.4.6	Electrostatic charge	1-5
1.4.7	Shock & vibration	1-5

2 TECHNICAL DESCRIPTION

2.1	The print system	2-1
2.2	Coding unit.....	2-2
2.3	Control unit.....	2-3
2.4	Sensors.....	2-5
2.4.1	Photocell.....	2-5
2.4.2	Encoder	2-5
2.5	Label design	2-6
2.5.1	Integrated label design program	2-6
2.5.2	NiceLabel	2-6

3 PRINT PROCESS DESCRIPTION

3.1	Print cycle	3-1
3.2	Printhead.....	3-1
3.3	Ink system.....	3-2
3.4	Spit function	3-2
3.5	User interface	3-3
3.5.1	Menu structure	3-3
3.5.2	LED indicators on control unit	3-3
3.5.3	Keyboard	3-4
3.5.4	System information.....	3-8
3.5.5	Menu structure	3-9

4 SAFETY

4.1	General	4-1
4.2	Control unit.....	4-1
4.2.1	General information.....	4-1
4.2.2	Power supply.....	4-2
4.2.3	Precautions before power-up	4-2
4.2.4	Precautions when opening the control unit	4-3

4.3	Anti-static precautions.....	4-3
4.3.1	Printhead	4-3
4.3.2	Printed circuit boards.....	4-3
4.4	Ink and cleaner.....	4-4
4.4.1	General safety measures	4-4
4.4.2	First aid measures	4-4
4.4.3	Warning labels	4-4
4.4.4	Caution labels	4-4

5 TRANSPORT & STORAGE

5.1	Printer equipment.....	5-1
5.1.1	Shipping and handling	5-1
5.1.2	Pre-transport procedure	5-1
5.1.3	Pre-storage procedure.....	5-2
5.2	Ink and cleaner.....	5-4
5.2.1	Handling and storage	5-4
5.2.2	Transport information	5-4

6 INSTALLATION

6.1	Requirements.....	6-1
6.1.1	Provided by the customer.....	6-1
6.1.2	Equipment.....	6-1
6.1.3	Optional parts	6-1
6.2	Unpacking	6-2
6.2.1	Coding unit.....	6-2
6.2.2	Control unit	6-3
6.2.3	Encoder (Optional)	6-3
6.2.4	Ink set	6-4
6.3	Coding unit mounting options	6-4
6.3.1	Distance between front plate and product.....	6-4
6.3.2	Ink reservoir	6-5
6.3.3	Ink reservoir orientation	6-5
6.3.4	Printhead rotation [X54] [X72]	6-6
6.3.5	Radial printhead rotation	6-6
6.3.6	Axial printhead rotation [X54] [X72].....	6-9
6.3.7	Radial and axial printhead rotation [X54] [X72].....	6-11
6.4	Positioning the sensors.....	6-12
6.4.1	Photocell for print request (X04).....	6-12
6.4.2	Photocell to enter BCD code into the buffer (X08)	6-12
6.4.3	Encoder (optional)	6-13
6.5	Mounting the control unit.....	6-14

7 COMMISSIONING

7.1	Preparing the control unit.....	7-1
7.2	Filling the ink system.....	7-2
7.3	Tuning the speed related parameters	7-5
7.3.1	Preparing for the first test print	7-5
7.3.2	Tuning the test print with the encoder disabled.....	7-7
7.3.3	Tuning the test print with the encoder enabled	7-8
7.4	General print parameter settings	7-8
7.4.1	Changing the print direction.....	7-8
7.4.2	Changing the print direction and mirroring the label.....	7-9
7.4.3	Setting the print request parameters	7-9
7.5	Spit parameter settings	7-10
7.5.1	Setting the spit parameters.....	7-10
7.5.2	Setting the ink low and ink out outputs.....	7-12

7.6	User settings	7-12
-----	---------------------	------

8 OPERATION

8.1	Powering up	8-1
8.2	Operational	8-2
8.2.1	Start printing	8-2
8.3	Operator data input	8-2
8.3.1	Text item input menu	8-3
8.3.2	Date advance input menu	8-4
8.3.3	Number start value input menu	8-4
8.4	Label management	8-5
8.4.1	Selecting a label for printing	8-5
8.4.2	List labels (Local files)	8-6
8.4.3	Add labels	8-6
8.4.4	Moving a label	8-8
8.4.5	Deleting a label	8-9
8.4.6	Editing a label	8-10
8.4.7	Creating a label	8-11
8.4.8	Showing a preview	8-15
8.5	Re-filling the ink reservoir	8-16
8.5.1	Purging the printhead	8-17
8.5.2	Priming the printhead	8-18
8.6	Adjusting printer settings	8-19
8.6.1	System settings	8-20
8.6.2	Printer settings	8-25
8.6.3	Signal settings	8-28
8.6.4	Network settings	8-32
8.6.5	Label settings	8-35
8.6.6	Print settings	8-37
8.7	Specific settings for the TsC20-Duo	8-39

9 DIAGNOSTICS / TROUBLESHOOTING

9.1	Service	9-1
9.1.1	Test labels	9-1
9.1.2	Fonts	9-2
9.1.3	Test	9-6
9.1.4	Printer	9-8
9.1.5	Diagnostics	9-10
9.1.6	Graphics	9-12
9.2	Information	9-15
9.2.1	General	9-15
9.2.2	Health	9-16
9.2.3	Backup	9-16
9.2.4	System Info	9-18
9.2.5	Report	9-19
9.2.6	Upgrade	9-21
9.3	Fault finding	9-23
9.3.1	Control unit	9-23
9.3.2	Coding unit	9-24
9.3.3	Print request sensor	9-26
9.3.4	Encoder	9-26
9.4	Error/warning messages	9-27
9.5	Poor print quality	9-27
9.5.1	General issues	9-27
9.5.2	Often seen print results	9-29

10 MAINTENANCE

10.1	Quick and regular checks	10-1
10.2	Nozzle maintenance	10-1
10.3	Yearly maintenance	10-1
10.4	Replacing parts of the printhead housing	10-1
10.4.1	Anti-static precautions	10-1
10.4.2	Open the printhead housing	10-2
10.4.3	Close the printhead housing.....	10-3
10.4.4	Replacing the printhead PCB [X18, X18si, X18+]	10-3
10.4.5	Replacing the printhead PCB [X54].....	10-4
10.4.6	Replacing the printhead PCB [X72].....	10-5
10.4.7	Replacing the piezo printhead [X18, X18si, X18+].....	10-6
10.4.8	Replacing the piezo printhead [X54]	10-6
10.4.9	Replacing the piezo printhead [X72]	10-7
10.4.10	Replacing the ink filter	10-8
10.5	Updating firmware and software	10-8

11 DISMANTLING & DISPOSAL

11.1	Dismantling	11-1
11.1.1	System	11-1
11.1.2	Ink reservoir	11-1
11.1.3	Printhead housing.....	11-1
11.1.4	Control unit	11-1
11.1.5	Sensor devices	11-1
11.1.6	Ink and cleaner	11-2
11.2	Disposal	11-2
11.2.1	Disposal method.....	11-2
11.2.2	Waste separation.....	11-2

Index

▪	Keywords	I
▪	Figures	III
Part 1; selecting a label for printing over Ethernet.		M-1
	Select Label command standard version (Unicode)	M-1
	Select Label command standard version (ANSI)	M-2
	Select Label command Escape version.....	M-2
Part 2; updating text fields inside the printed label over TCP/IP.....		M-3
	Update text field command; standard version	M-3
	Update text field command; Escape version.....	M-4

Appendices

Appendix A	Specifications.....	A-1
Appendix B	Dimensions	B-1
Appendix C	Part lists & illustrations	C-1
Appendix D	Connections.....	D-1
Appendix E	NiceLabel driver tutorials	E-1
Appendix F	Quick reference menu structure	F-1
Appendix G	Error list	G-1
Appendix H	Using the BCD label selection	H-1
Appendix I	Using variables in labels	I-1
Appendix J	Setting and using the security option	J-1
Appendix K	Restore factory settings using dipswitch	K-1
Appendix L	The automation feature	L-1
Appendix M	Selecting and updating a label over TCP/IP.....	M-1
Appendix N	Remapping inputs & outputs	N-1
Appendix O	EC Declaration of conformity.....	O-1

1 INTRODUCTION

1.1 Qualified personnel

Operators are qualified when they have read and understand sections 1 to 8 of this manual. A specific preliminary training is not required.

Technicians that carry out repairs and technical maintenance on the printer equipment should have secondary technical education or comparable technical level of knowledge through practical experience.

Installation or servicing of the printer must only be performed by qualified personnel of Korthofah BV or a local distributor, which is designated by Korthofah BV.

For customer installations authorisation must be obtained from Korthofah BV or a local distributor, which is designated by Korthofah BV.

1.2 Elementary personal protection

- Use the printer only in a well ventilated area.
- Do not eat or drink while working with the ink or cleaner.

When at risk for contact with the ink or cleaner:

- Wear chemical resistant gloves.
- Use safety goggles or face shield in case of splash risk.
- Wear suitable protective clothing as protection against splashing of or contamination with ink or cleaner.

When installing or servicing the equipment:

- Ensure that the host machine is stopped.
- Ensure the control unit of the printer is switched off.

Please read the SAFETY section and the SDS of the ink used for more information. The SDS can be downloaded from the Kortho website (www.kortho.com).

1.3 Intended Use

The GraphicJet X-series are industrial printers and are designed to print directly on substrates e.g. cardboard, wood and paper. The printers can print labels with fixed and/or dynamic items. Dynamic items are items like operator input text, number, date and time. Beside text related items, the printer can also print items such as barcodes, shift-codes and graphics.

The labels can be designed with a PC based design tool or they can be designed on the control unit. The labels designed with a PC based design tool can be downloaded to the control unit by Ethernet or by USB thumbdrive. The labels will be stored in the label memory.



Beware:

USB must be formatted as FAT12, FAT16, FAT32, exFAT, TexFAT in order to be supported. The NTFS file system is not supported in any of the Windows CE versions.

INTRODUCTION

Normal use means use under normal conditions as described in this manual i.e. use inks recommended by Korthofah BV and use only original spare parts.

The printer may not be used in areas which have a fire or explosion hazard.

Korthofah BV does not accept any liability for damage to the equipment or personal injury resulting from improper use of the equipment or improper maintenance. Neither does Korthofah BV accept any liability for the normal wear-and-tear of the equipment.

1.4 Specifications

Only general specifications are described in this section. Refer to Appendix A for more detailed specifications.

1.4.1 Coding unit



Fig. 1.1 Coding units, global dimensions

A general impression of the coding unit dimensions is given in Fig. 1.1. The dimensions (H x W x D, in mm) (bracket included) and the typical specifications of coding units are:

Part.nr.	Coding unit	Height	Width	Depth	Print area	Print speed	Ink type
817752	Coding unit X18	322	170	477	17,5x1500	0-40m/min	GJ8
818157	Coding unit X18+	322	170	477	17,5x1500	0-60m/min	GJ8
818227	Coding unit X18si	322	170	477	17,5x1500	0-40m/min	GJ4
817555	Coding unit X54	322	183	480	53,7x2000	0-60m/min	GJ8
819041	Coding unit X72	322	190	480	71,8x2000	0-45m/min	GJ9

The ambient temperature must be between 5 °C and 40 °C, with a relative humidity between 10% and 90% (non-condensing).

Use only Kortho GJ inks and cleaners for this printer. Make sure the ink and cleaner used match.

1.4.2 Control unit

A general impression of the control unit TsC20 dimensions is given in Fig. 1.2 . The typical specifications of the control units are:

Part.nr.	Control unit	Height	Width	Depth	Coding unit
818131	Control unit TsC20-X Duo	203	258	153	2



Beware:

One can connect two coding units to the control unit TsC20-X Duo. Both coding units have to be of the same type, so 2x X18 series, 2x X54-series or 2x X72-series. Different types of X18 can be used together.



Fig. 1.2 Control unit, global dimensions

The electrical requirements for the power supply of a Controller TcC20 or TsC20-Duo in combination with one coding unit X18/X18+/X18si/X54/X72 are:

- Voltage rating: 100-240 VAC;
- Frequency rating: 50 / 60Hz;
- Current rating: 0,5A / 0,25A
- Power rating: 50VAmx.
- Fuse rating: 2x T2,5A 250VAC (slow acting).

The electrical requirements for the power supply of a controller TcC20-Duo in combination with two coding units X18/X18+/X18si/X54/X72 are:

- Voltage rating: 100-240 VAC;
- Frequency rating: 50 / 60Hz;
- Current rating: 0,85A / 0,45A
- Power rating: 85VAmx.
- Fuse rating: 2x T2,5A 250VAC (slow acting).

**CAUTION:**

Make sure the interface cable is no longer than 30m and is shielded. Using a cable longer than 30m can cause EMC interference.

The control unit has a bespoke hardware user interface, communication ports and host I/O-ports.

The ambient temperature must be between 5 °C and 40 °C, with a relative humidity between 10% and 90% (non-condensing).

1.4.3 Ink

The Kortho inks have been developed for use in conjunction with the GraphicJet X-series printhead to print onto a range of substrates. The inks are either oil based, used on porous substrates like cardboard, or solvent based, used on non-porous substrates like PVC water pipes.

The oil based inks are low odour, low volatility pigmented inks. The use of a low volatility oil gives rapid dry times on appropriate substrates, such as paper and card board, and gives reliable performance in the GraphicJet printheads.

The solvent based inks are developed to give a relatively fast drying time on the substrate, this while the ink will only slowly dry into the print head. This ensures that the print head will not be permanently blocked after a longer period of not using the printer. Nevertheless there is always a chance the ink will dry into the print head and will permanently block the print head. To prevent this it is important to either use the printer regularly or to purge the print head with regular intervals. The length of the interval depends on the ink used (layout of the print and printfrequency) and type of ink used and ambient circumstances, like temperature and humidity, please refer to the ink specification sheet for more detailed information.

The inks are designed for outdoor use and with a suitable substrate; the ink should withstand 1-year exposure. All pigments are lightfast. The ink is resistant to water and common solvents when used on suitably resistant substrates.

The ink must be protected from light and stored or used between 5 °C and 40 °C.

The recommended ambient temperature while printing is between 15 °C and 35 °C.

1.4.4 Label features

Label:

Name: User defined name.

Test label: A label that is permanently available (cannot be deleted) and specifically designed for making test prints to check the print quality and the right setting of several parameters.

Items: Text, multiple line text, number, date, time, shiftcode, barcode, line and box items and graphics. These items are placed in a label using label design software or the on-board label design function.

Data: Fixed and variable.

Max. items: 25 number items per label (per coding unit). 200 characters per text item when using the on-board label editor. When designed with label design software the limit depends on the software used and is limited to a maximum of 2000 characters by the print engine.

Font:

General: Full Windows TTF font support. The following fonts are pre-installed in the printer: Arial, **Arial Black**, Arial Narrow, **Century Gothic**, Courier New, Georgia, **Liberations Sans**, **Liberations Serif**, Lucida Sans Unicode, Microsoft Sans Serif, Segoe UI, Segoe UI licht, Segoe UI Semi bold, **Tahoma**, Times New Roman, Trebuchet MS, Verdana.

Windows driver: The fonts that are marked in bold are also implemented in the Windows driver. When using the driver these fonts can be used to print fixed and variable text e.g. time, date, operator input text. When another font is used in an item, the driver will convert the item into a bitmap.

Controller: The fonts used in a label also need to be installed on the control unit. When a font is used in a label which is not installed on the controller, the controller will select an alternative font which is installed on the controller. This will affect the layout of the label. When using the Bold option for text items, install the bold font if possible. If not, Windows will boldface the selected font, which makes it slower.

Barcode formats: Internal barcode generator, which supports all commonly used barcodes among which are Codabar, Code 2 of 5, Code128, Data Matrix, EAN128, EAN13, EAN8, RSS-14, UPC A, UPC E, QR-code etc.

Items:

Graphic: In jpg, bmp or png format (automatic black/white conversion).

Dynamic: Number, date, time and shiftcode.

Operator input: Text, number, date offset.

Variables: It is possible to use variables in the label design which can be combined in a single text or barcode item

Label download: Through Ethernet or a USB thumbdrive. Ethernet can be used to download a label to the print memory. By using the USB thumbdrive labels can only be copied to the label memory.

Storage capacity: 40MB (approximately 400 labels). This memory can be used for storage of:

- a. Labels
- b. Graphics
- c. Fonts

1.4.5 Life span

The life span of the equipment is five years, except for the printhead, under normal use and in compliance with the indicated maintenance periods.

The life span can be negatively influenced by improper/uninformed use of the equipment or improper maintenance, repair or modification by unqualified personnel, or repair with non-original parts. No claims for guarantee or compensation for damages will be accepted in such instances.

1.4.6 Electrostatic charge

Make sure that the substrate is not able to build up an electrostatic charge near the printhead, i.e. use conductive rolls and bearings for substrate guidance, place an ESD brush or an ionizing air bar just before the printer.

An electrostatic charge will disturb the print by electrostatic influence on the printhead, this may cause permanent printhead failure.

1.4.7 Shock & vibration

The printer should be installed on a low vibration location.

It is recommended that the coding unit is protected from shock and vibration, as this will have severe impact on the printed label quality and printhead life.

2 TECHNICAL DESCRIPTION

This section is meant for all users. It describes all the main parts of the printer system.

2.1 The print system

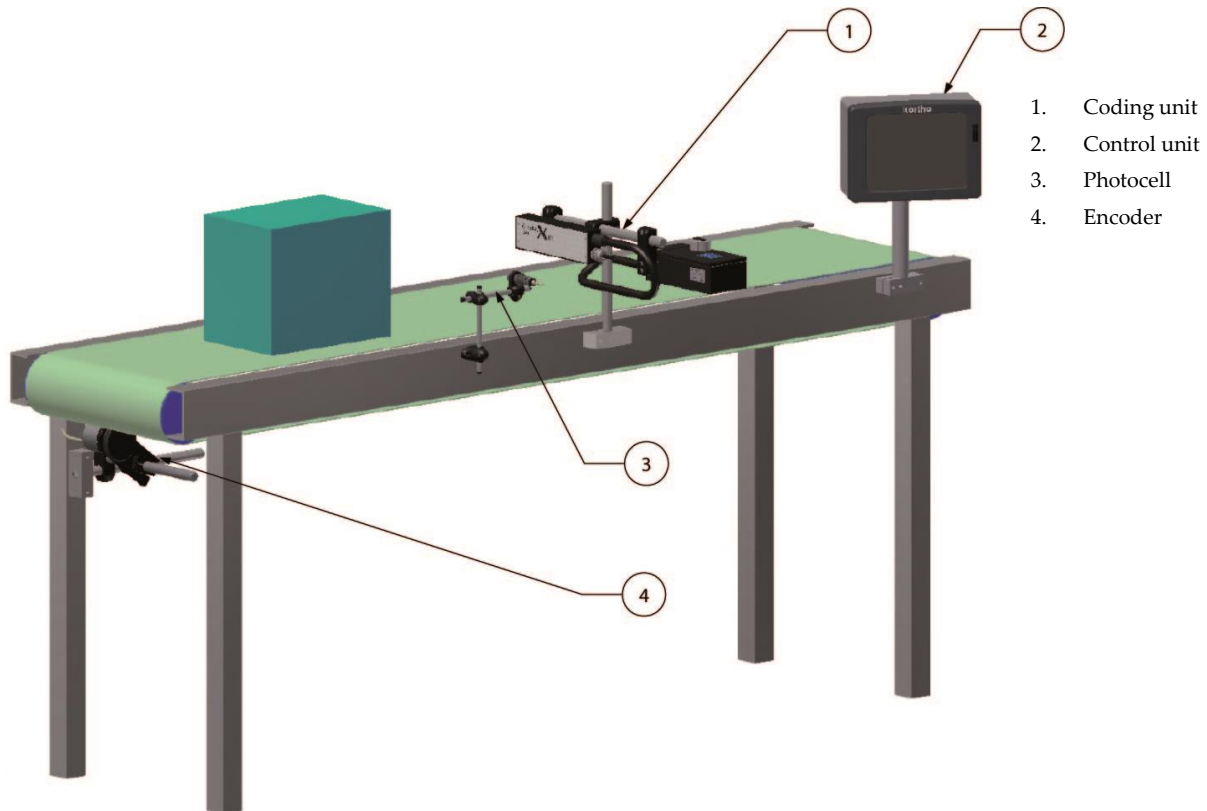

Fig. 2.1 The printer system

A typical GraphicJet system is shown in Fig. 2.1. The box/product is moved by a conveyor belt along the front of the photocell and the coding unit. The photocell is connected to the control unit. An encoder can also be connected to the control unit but this is optional. If the speed is not constant, an encoder is required for optimum print quality, otherwise the print will be squeezed in or stretched out. The control unit is connected to the coding unit(s). Up to two coding units can be connected to one control unit. Both coding units will generate a print based on the printsignal. When the speed is set by the user (external encoder off), both heads can also print at a different speed.

All connections between printer and peripheral devices are made on the control unit i.e. print request signal, alarm signals and Ethernet connection.

The GraphicJet printhead receives the label from the control unit and prints it on the substrate. The design resolution is 185 DPI in height and 185 DPI in length for the X18 series and 180DPI in height and length for the X54 and X72. The printed resolution (horizontal) will be 185 DPI for the X18 series and 180 DPI for the X54 and X72 series when the external encoder is used or when the accurate product speed is entered.

When the print process has finished, the label variables will be updated.

After printing a label the printer is in stand-by mode again and awaiting the next print request signal.

After receiving the next print request signal the time and date items will be updated after which the system will print the completely updated label.

2.2 Coding unit

1. Ink reservoir
2. Printhead housing
3. Support

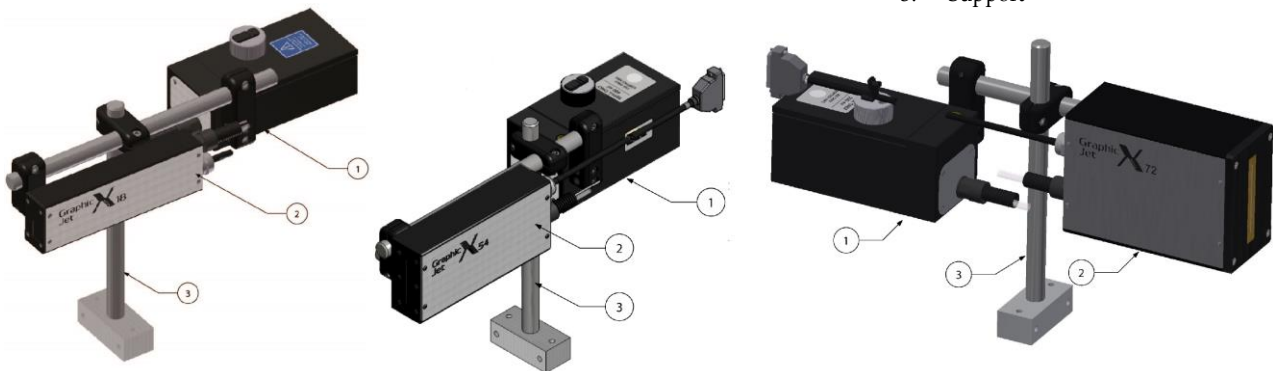
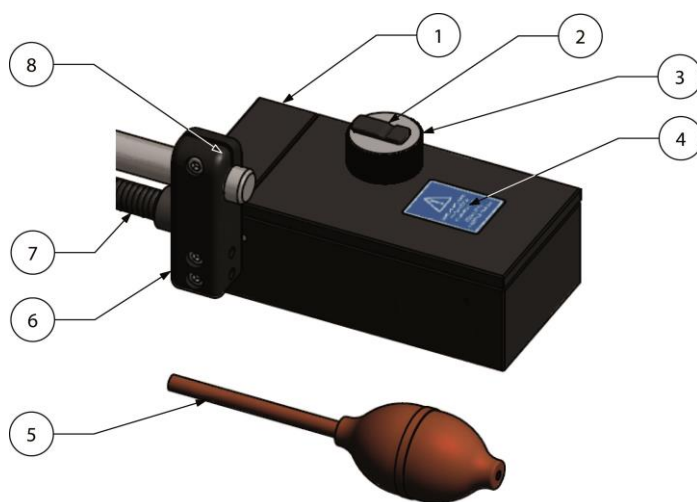
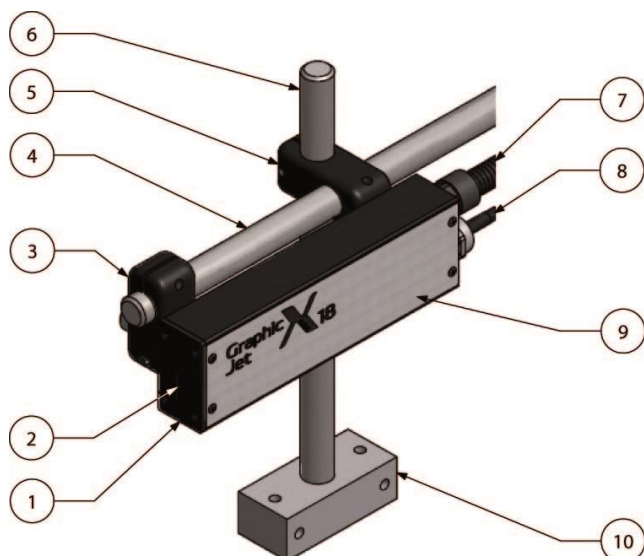

Fig. 2.2 Coding unit, parts



1. Ink reservoir
2. Fitting for prime bulb
3. Screw cap
4. Refill label
5. Prime bulb with tube
6. Reservoir mounting clamp
7. Flexible conduit to printhead housing
8. Built-in spirit leveller (not shown – positioned behind the clamp)

Fig. 2.3 Ink reservoir, parts



1. Front plate
2. Printhead nozzle plate
3. Mounting clamp
4. Support shaft
5. Support clamp
6. Support pole
7. Flexible conduit to ink reservoir
8. Power/data cable
9. Printhead housing
10. Support mounting block

Fig. 2.4 Printhead housing & bracket parts

TECHNICAL DESCRIPTION

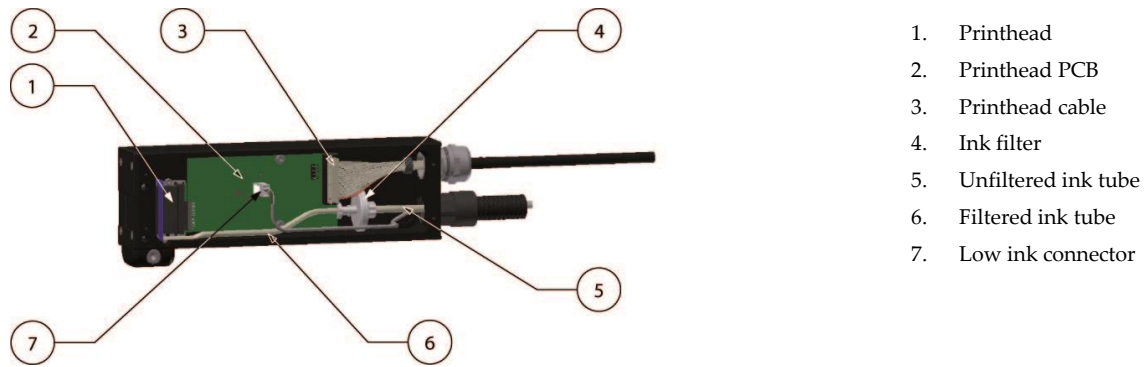

Fig. 2.5 Printhead interior, parts

The printhead has a small integrated filter designed to stop particles entering the printhead and blocking the nozzles. If this filter starts to become excessively blocked, flow rate will decrease and the performance of the printhead will severely decrease. The integrated filter cannot be replaced or cleaned.

A primary system filter is filtering the ink (Fig. 2.5. item 4), prior to the integrated filter. This will ensure that the integrated filter will last for the lifetime of the printhead. This filter can be replaced.

The difference between the X18 and X18+ is the printhead used. The printheads are easy to recognize, as the printhead of the X18 is black and the printhead of the X18+ is red/orange.

The difference between the X18 and X18si is the material used for tubing and sealings. The sealings are easy to recognize, as the sealings for the oil based inks used in the X18, X18+, X54 and X72 are marked with one notch and the sealings for solvent based inks used in the X18si are marked with 2 notches.

2.3 Control unit

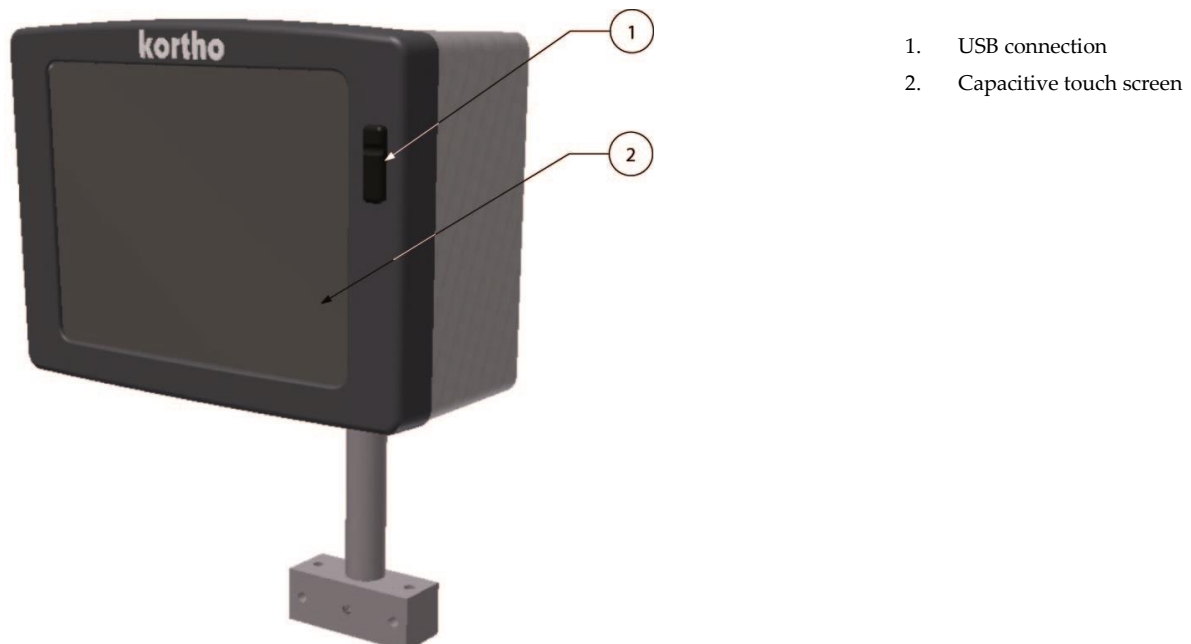

Fig. 2.6 Control unit



CAUTION:

Do not use an extension cable for connecting the USB thumbdrive to the controller, but place the USB thumbdrive directly in the controller. Using an extension cable can cause EMC interference.

TECHNICAL DESCRIPTION

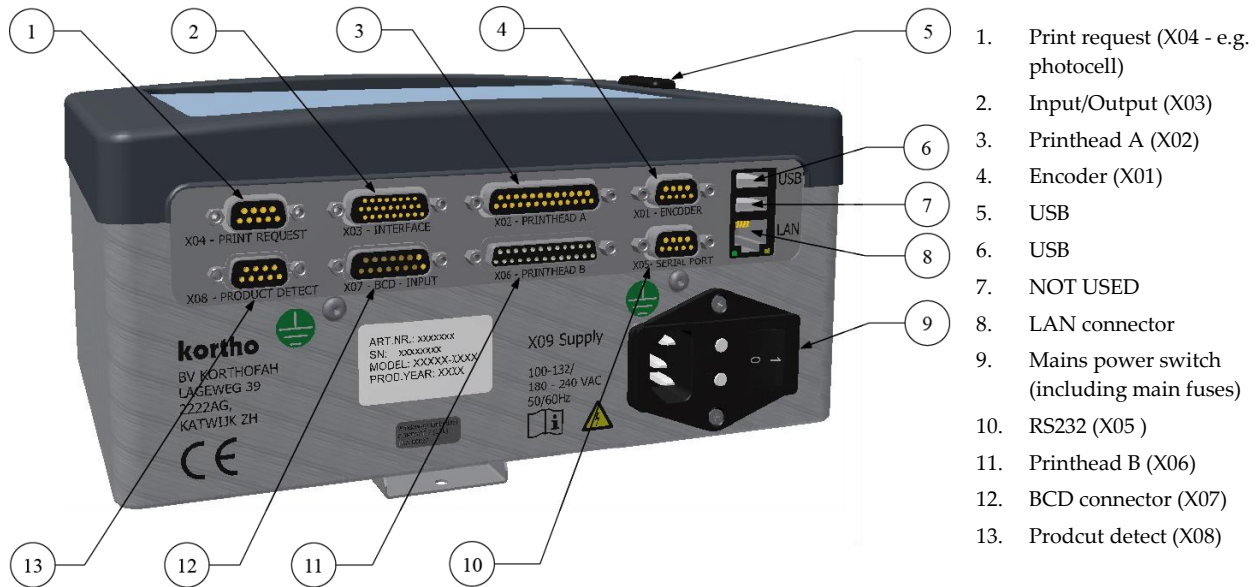

Fig. 2.7 Control unit, connections

2.4 Sensors

2.4.1 Photocell

The photocell is used to detect the substrate to print on.



1. Detection indicator
2. Sensitivity adjustment
3. Sensor connector
4. Photocell lens

Fig. 2.8 Photocell

2.4.2 Encoder

The encoder is used to measure the movement of the product to print on. This measurement is used to calculate the correct print speed at which the printer will print.

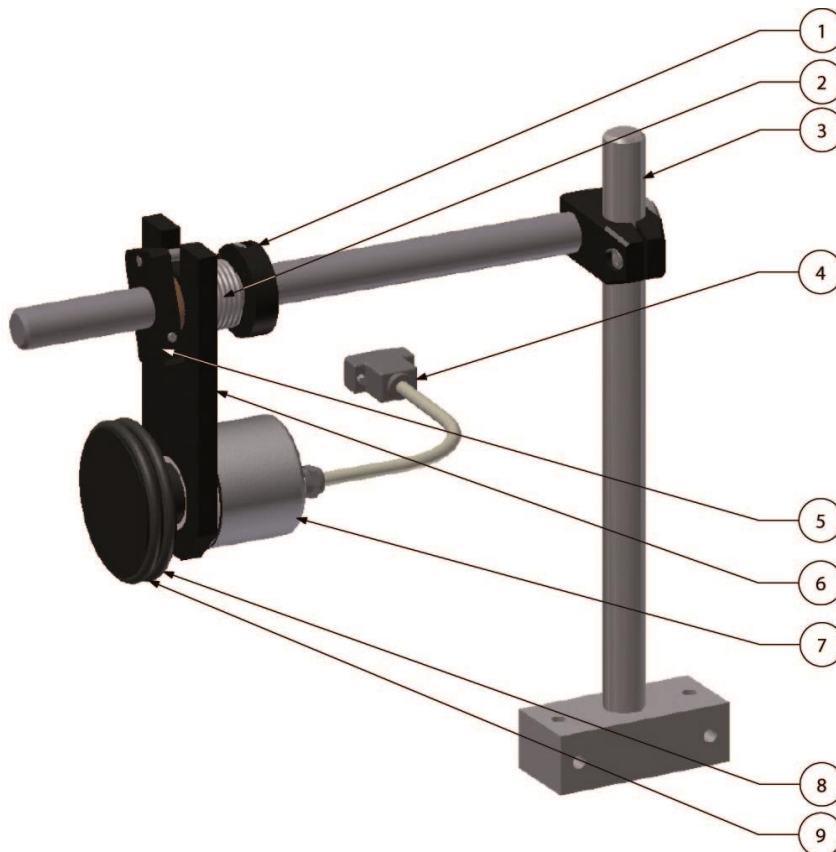

1. Spring clamp
2. Spring
3. Encoder support
4. Encoder connector
5. Lever limiter
6. Encoder lever
7. Encoder
8. Encoder wheel
9. Rubber O-ring (2x)

Fig. 2.9 Encoder

The encoder for the X18 and X54 are the same. The X72 requires a different encoder and measuring wheel. The interface of the encoders are the same, so no damage will occur if these are interchanged. The printed label will however not be printed correctly. (stretched or compressed)

2.5 Label design

A label can be designed by the integrated label design program or NiceLabel in combination with the Windows driver. Other software can be used in combination with the Windows driver, but depending on the software, most internal functions will not be available. Please consult Korthofah or your local distributor for further information.

2.5.1 Integrated label design program

The control unit offers the option to design a label on screen. The label design option offers the most common items and item options used in a label. If advanced features are required, the label needs to be designed with a label design program that runs on a PC, like NiceLabel.

2.5.2 NiceLabel

Labels can also be created by using NiceLabel or any other windows based program using the Kortho printer driver for NiceLabel. When using this driver in combination with the NiceLabel software one can use the full options this software program offers including variable text and data field. One should note that using the NiceLabel Windows driver in combination with any other program will limit the label item options to fixed items. For information about the installation of the driver and the use of the NiceLabel, see Appendix E.

3 PRINT PROCESS DESCRIPTION

3.1 Print cycle

The purpose of the printer is to print a label on a substrate. A label is digital data and is stored in the memory of the control unit. The control unit converts the label into a bitmap. The printhead receives this bitmap pixel-column by pixel-column and uses it to fire ink dots on the substrate. The ink drop fire rate is controlled by pulses, which are generated by either an internal clock or an external encoder. The vertical dot resolution is 185 dpi for the X18 series and 180DPI for the X54 and X72 series. The horizontal dot resolution depends on the speed setting. At the correct speed, by parameter setting or use of an encoder, the horizontal print resolution is 185 dpi for the X18-series and 180 dpi for the X54 and X72 series.

The print cycle is initiated with a signal, called 'print request', and generally generated by a photocell, which detects the product or special mark on the substrate. When a print has been made, the bitmap will be updated, if necessary, for label items such as time, date and number. When this is done, the busy output is deactivated and the printer is ready for receiving the next print request.

3.2 Printhead

The heart of the GraphicJet printer is the printhead. The printhead uses patented digital drop on demand (DOD) piezo ink jet printing technology. It is seen in a range of industrial printing applications, including coding and marking, as it is a versatile technology able to print on a wide variety of substrates.

This printing technology uses a ceramic material that deforms when an electric field is applied to it. This deformation is harnessed in order to eject ink from each of the printhead's ink channels in a highly controlled and repeatable manner. Each pixel on the substrate is either covered with ink or not - a binary choice.

In simplified overview, the technology consists of a series of ink chambers packed together into a printhead, divided by shared chamber walls with an electrode attached to each side (Fig. 3.1).



Fig. 3.1 Piezo printhead technology

The piezo material is made of lead zirconate titanate (PZT). This ferroelectric ceramics becomes piezo-electric when poled.

When a voltage is applied across this material the material distorts or bends. This phenomenon is implemented in the printhead by machining rows of parallel channels into a PZT block. An electrode is then placed onto the sides of the channel walls allowing a voltage to be applied across it. The way in which the wall bends due to the applied voltage is known as 'shear mode'. Two channels share the wall, and hence the term shared wall.

The channels are filled with ink and a pressure wave inside the ink is generated due to the distortion of the PZT walls. The height and width of the chambers do not alter; they simply just shift to one side. This movement generates the pressure wave in the ink. This pressure wave forces ink out of the end of the channels via the printhead's nozzle.

Shear mode is more efficient than the direct mode of printing employed by other inkjet technologies as it effects a greater deformation in the piezoelectric material without using more energy.

3.3 Ink system

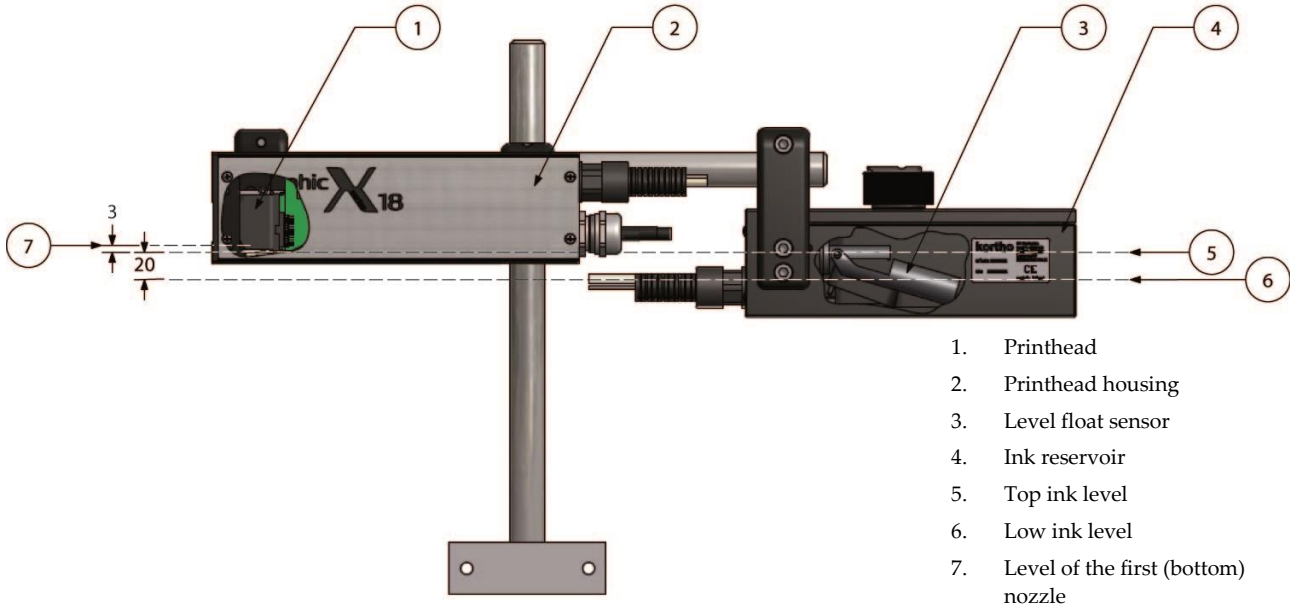

Fig. 3.2 Printhead and ink levels

The printhead acts like a pump and therefore is capable of pulling ink through it. A negative ink supply pressure must be used for the printhead to operate properly.

The most common and most simple way to supply a negative pressure ink supply is to position the ink reservoir below that of the printhead nozzles. The ink reservoir is open to atmospheric pressure.

The orientation of the printhead is between horizontal, as in Fig. 3.2, and vertical position, see section 6.3. The vertical orientation is only used for printing downwards. Upwards printing is not possible due to the very high risk of clogging the nozzles.

It is important that for any orientation of the printhead the top ink level is at least 3mm (X18 and X54 series) or 10mm (X72 series) below the level of the first (bottom) nozzle, otherwise the printhead starts 'bleeding' ink.

3.4 Spit function

In extreme cases, it is necessary to enable the spit timer. This timer triggers the printhead to spit ink through all the nozzles and in this way prevents clogging of the nozzles.

The disadvantage of using the spitting timer is waste of ink and probably the need of a device that collects the ink while spitting. Refer to chapter 7.5.1 Setting the spit parameters for further information.

3.5 User interface

The user interface on the control unit consists of a capacitive touch panel displaying the menu structure of operator menus.

The touch panel consists of a capacitive touch screen and a TFT panel. The screen can also be operated with gloves on (supplied with the ink). A stylus for capacitive touch screens can also be used if required.

3.5.1 Menu structure

The screen is divided in four parts, see Fig. 3.3. Section 1 shows the 4 main menu options:

1. Print (label selection and label management).
2. Settings (all printer and interface settings).
3. Service and Diagnostics (service and diagnostic functions).
4. Information (system information).

Section 2 shows the submenus available when the Printer setting icon is selected. When another main menu option is selected in section 1, different submenus will be shown.

Section 3 shows the menu items available in the submenu selected in section 2. Depending on the submenu selected the contents of this section will change. It's possible that not all the functions are displayed on the screen. To access the remaining functions, simply drag the screen upwards

Section 4 shows the status of the printer, the Start (I) and Pause (O) button and the coding units connected to the control unit (A and B).

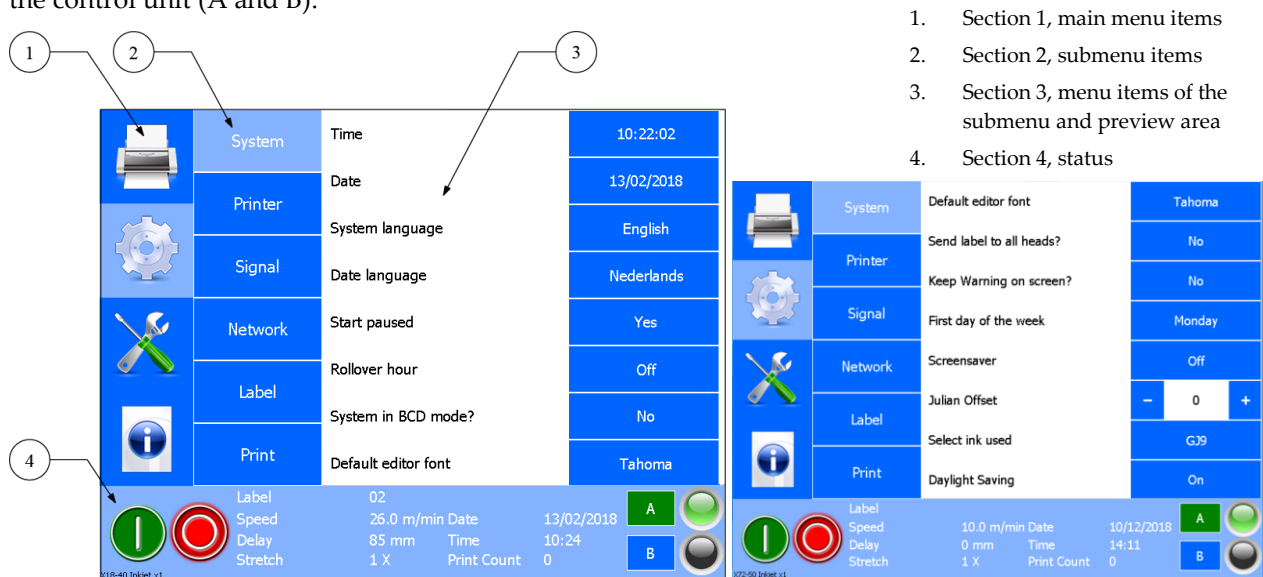

Fig. 3.3 Screen layout

3.5.2 LED indicators on control unit

The status screen of the control unit shows a LED indicator indicating if the printhead(s) connected to the control unit is (are) ready to print (green) or not (orange). E.g. when there is not enough ink present in the inksystem the LED indicator will turn orange and a low ink message will be shown on screen.

3.5.3 Keyboard

Data and settings can be entered through a keyboard that will be displayed on the TFT panel.

The keyboard has four screens. The first screen is shown below. The tiny round indicators at the bottom of the screen show which of the four keyboard screens is currently displayed. One can select another keyboard by either using the relevant buttons or by swiping over the round indicators at the bottom of the screen.

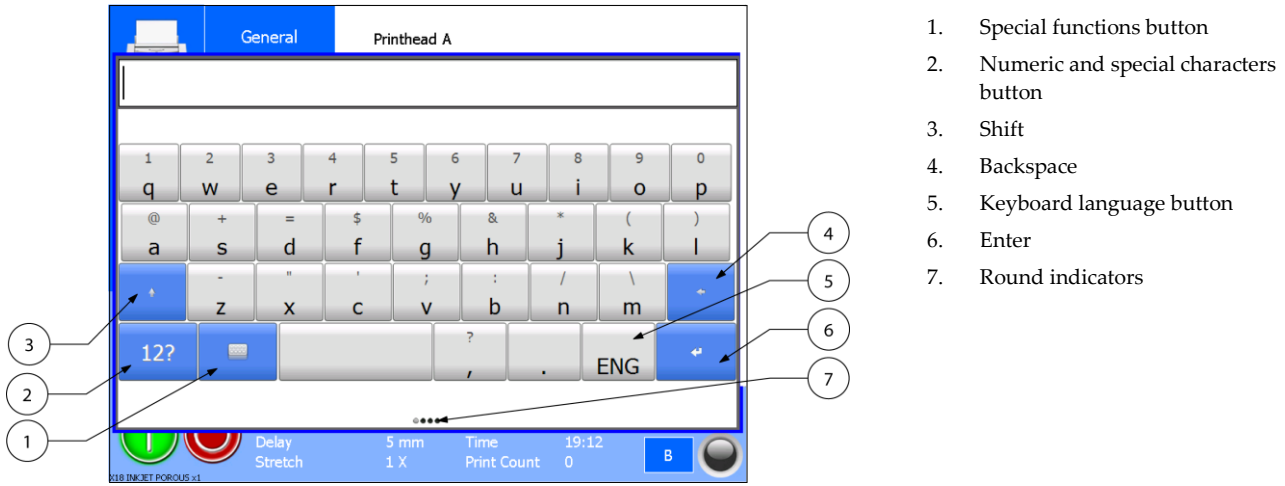

Fig. 3.4 First keyboard screen

To set the keyboard language

The keyboard language can be set by touching the Keyboard language button and selecting the required language, 5 in Fig. 3.4.

After the selection has been made the keyboard will be set to the selected language, e.g. Arabic as shown in figure Fig. 3.5.



Fig. 3.5 Arabic keyboard

To use the keyboards superscript alphanumerics:

1. Touch and hold the desired key.
2. Drag your finger to the left or right to select the character of choice.

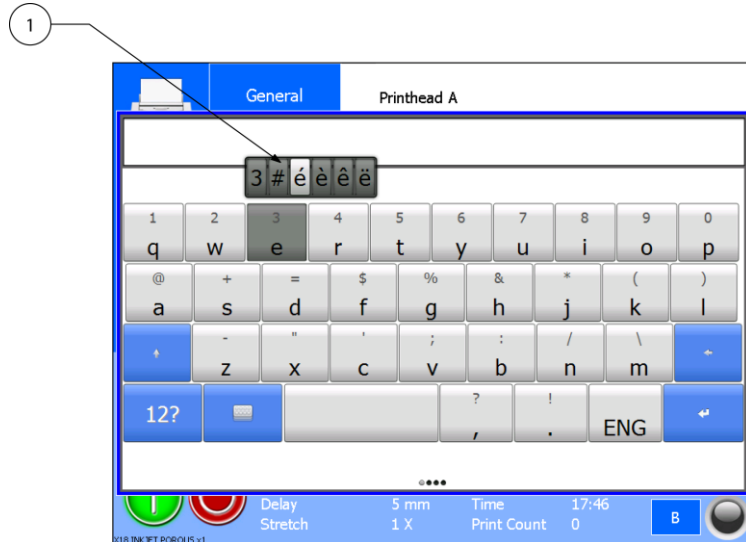

1. Alternative alphanumerics

Fig. 3.6 First keyboard screen, alternative alphanumerics

To use the Numeric and special character keyboard

An alternative way to select a digit is to touch the numeric and special characters button. The second keyboard screen will appear.

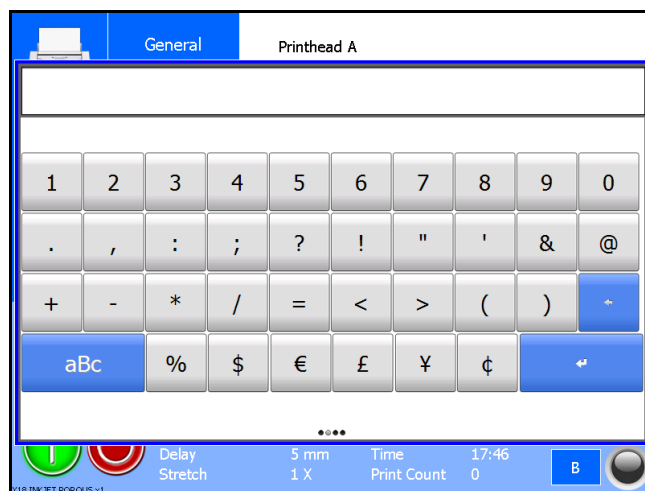

Fig. 3.7 Second keyboard screen, numeric and special characters

To use the Commonly used text keyboard

For entering commonly used text the third keyboard screen can be used. One can store frequently used texts in this keyboard. To enter this screen either swipe over the round indicators at the bottom of the screen or touch the special functions button in the first screen to enter the fourth screen and touch FX.

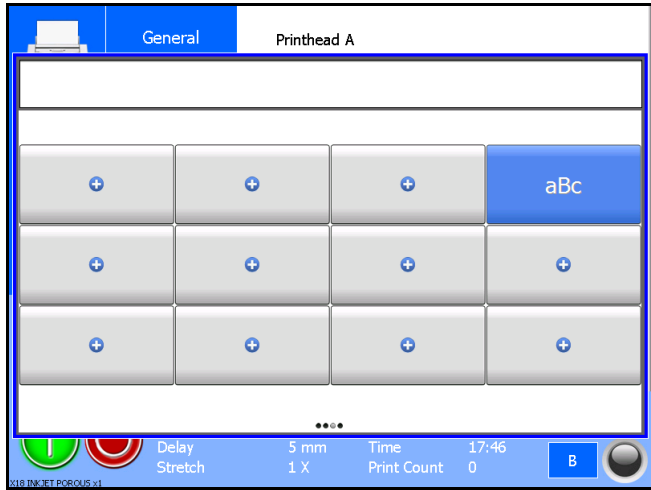

Fig. 3.8 Third keyboard screen, commonly used text

To program the buttons in the third screen:

1. Touch the special functions button on the first keyboard screen.
2. Touch the FX button.

The screen as shown in Fig. 3.8 will appear.

3. Touch one of the + buttons and enter the data to be stored (only one line can be stored), see Fig. 3.9.

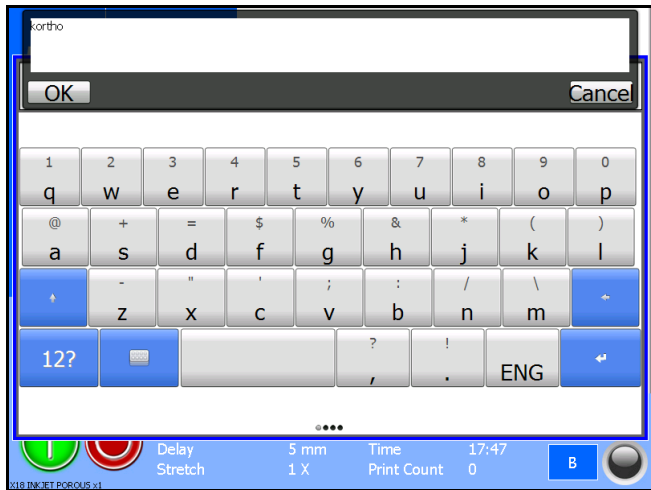

Fig. 3.9 Programming third keyboard screen buttons, entering text

4. Touch the OK button to store the text.

The button is now labelled with the text entered, see Fig. 3.10. Touching this button enters the text where required.

The text in a button can be deleted or modified later on.

A text placed by using the third keyboard screen will be treated as normal text, so the text can be deleted or modified if required.

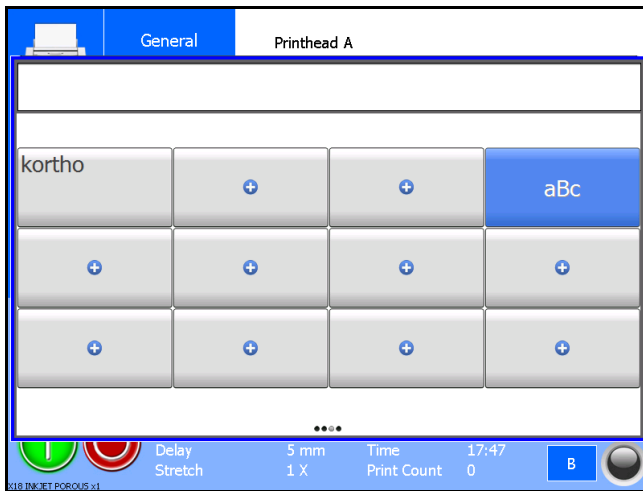

Fig. 3.10 Programming third keyboard screen buttons, entering text

To use the Special functions keyboard.

To edit text and use cursor controls, touch the keyboard button. This following screen will appear:



Fig. 3.11 Fourth keyboard screen, edit text and use cursor controls

To return to the first screen touch the *aBc* button.

To return to the second screen touch the *12?* button.

To return to the third screen touch the *FX* button.

To use the numeric keyboard

Beside the standard keyboard there is also a numeric keyboard available for all numeric items/entries, see figure Fig. 3.12.

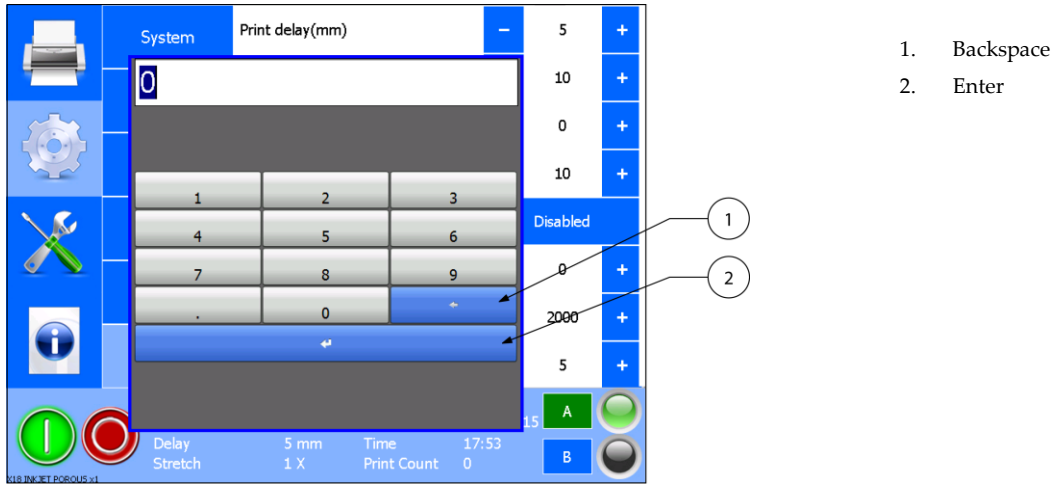
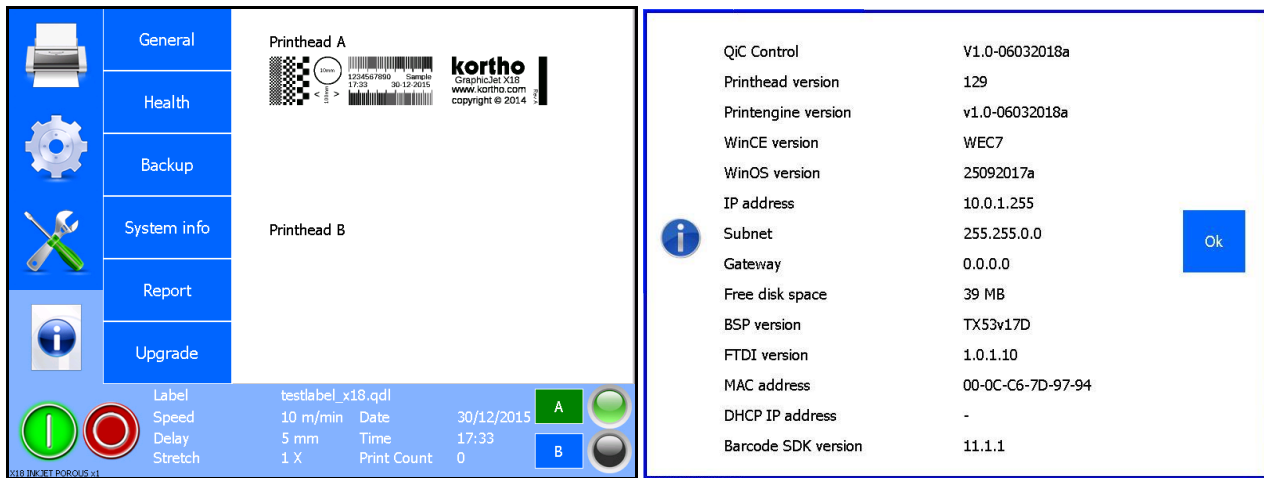

Fig. 3.12 Numeric keyboard

3.5.4 System information

The firmware versions installed on the control unit can be displayed on screen by pressing *System Info* in the Information menu.



A

B

Fig. 3.13 Entering the System information screen

3.5.5 Menu structure

Menu Structure Tsc20

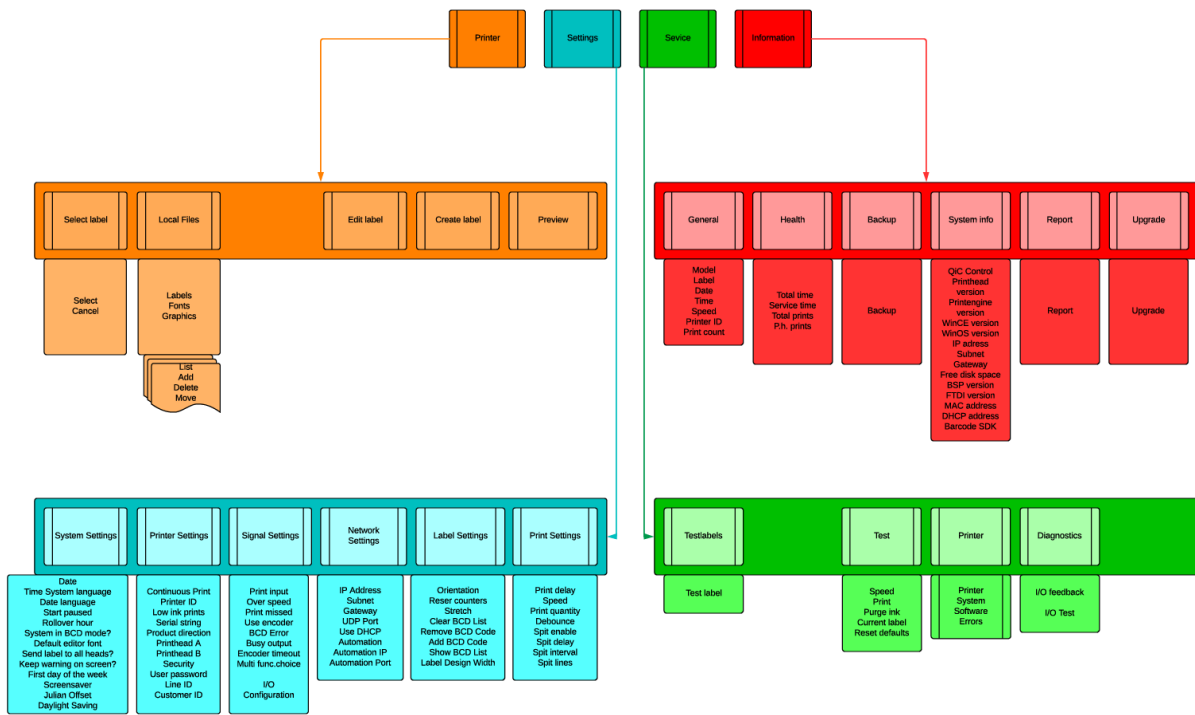

Fig. 3.14 Standard menu structure

Refer to Appendix F for a full-scale sheet of the menu structure.

PRINT PROCESS DESCRIPTION

This page was left intentionally blank.

4 SAFETY

This product is designed to conform to all applicable directives, and their relevant harmonized standards, of the European Council.

4.1 General

Make sure the location of the installation does not prevent people doing their job, there is sufficient light present for operating the printer and for maintenance and that the location is accessible for operating the printer and for maintenance.

NEVER check if the printer is actually printing by looking direct towards the printhead, this as there is a change the ink will be squired into ones eyes causing serious eye damage.

ALWAYS disconnect the power to the control unit before removing any connectors or covers:

- Switch off the control unit.
- Remove the plug from the mains power supply.
- DO NOT operate the printer when any cover is removed.
- DO NOT LEAVE tools, screws or other parts inside the coding unit and/or control unit when re-assembling the equipment.
- USE all screws to fasten the covers.

The inks and cleaners used with the printer come with a SDS. When accidents involving inks and/or cleaners occur, please refer to the corresponding SDS for appropriate actions to be taken. The SDS can be downloaded from the Kortho website (www.kortho.com). When working with chemicals in general:

- Provide adequate general and local exhaust ventilation.
- Wash hands, forearms and face thoroughly after handling chemical products, before eating, smoking and using the lavatory and at the end of the working period.
- Contaminated clothing should be removed.
- Ensure that eyewash stations and safety showers are close to the working station location.
- Wear personal protection equipment if the SDS and/or risk assessment points out this will be required. In general: face protection / safety goggles / chemical-resistant gloves / protective clothing / breathing apparatus.

4.2 Control unit

4.2.1 General information

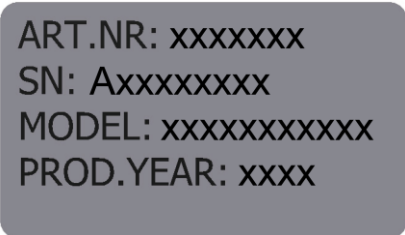

ART.NR: xxxxxxxx
SN: Axxxxxxxxx
MODEL: xxxxxxxxxxxx
PROD.YEAR: xxxx

Fig. 4.1 Control unit identification label

The part number and serial number of the control unit can be found on the identification label which is also located on the bottom of the control unit, see Fig. 4.1. The coding unit has its own part number and serial number. The coding unit identification label can be found on the side of the coding units printhead housing. The contact details of Korthofah can be found on bottom of the control unit, see Fig. 4.2.

4.2.2 Power supply

For safe operation, the power cable to the control unit must be connected to a properly grounded single-phase supply of the appropriate voltage. The power supply must comply with the power supply information that is written on the back of the control unit, see Fig. 4.2 and refer to section Appendix A.

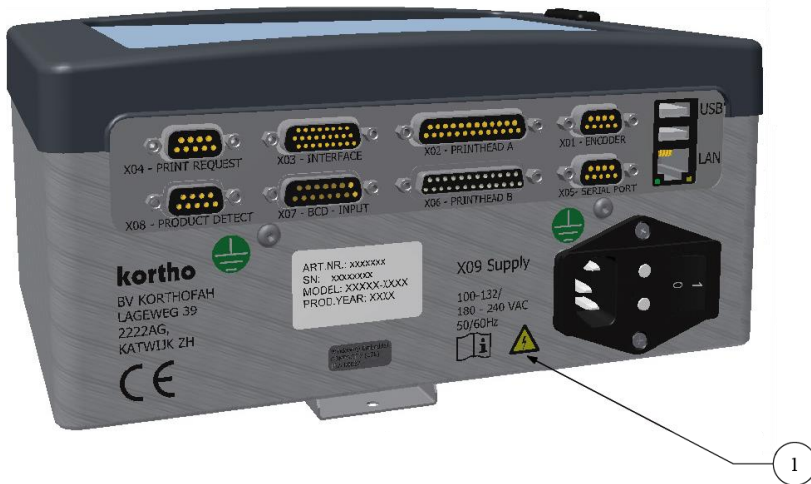

1. Power supply information

Fig. 4.2 Power supply information

Verify that no significant potential difference exists between the single-phase protective earth of the printer and the frame ground of the host machine.

The wire colour code for the supply cable is:

- BROWN for Line (L)
- BLUE for Neutral (N)
- GREEN/YELLOW for Protective Earth (PE)

When installing or servicing the equipment ensure that the host machine is switched off.

4.2.3 Precautions before power-up

Check at every printer power-up if all these connections are secured:

1. The cable/conduit (X02/X06) between the control unit and the coding unit(s).
2. The mains power plug (X09).
3. The print request cable (X04). (info: photocell or host-interface)
4. The input/output cable (X03). (option)
5. The encoder cable (X01). (option)
6. The LAN cable (LAN) (option)
7. The USB connection (USB, 2x) (option)
8. The BCD cable (X07) (option)
9. The RS232 communication cable (X05). (option)
10. The BCD product detect cable (X08) (option)

4.2.4 Precautions when opening the control unit



1. Attention label

Fig. 4.3 Attention label for opening control unit

The control unit connector plate has an attention label (Fig. 4.3) to alert the user to read the manual before opening the control unit.

ALWAYS disconnect the power to the control unit before removing any connectors or covers:

- Switch off the control unit.
- Remove the plug from the mains power supply.
- **DO NOT** operate the printer when the cover is removed.
- **DO NOT LEAVE** tools, screws or other parts inside the control unit when re-assembling the equipment.
- **USE** all six screws to fasten the cover.

4.3 Anti-static precautions

4.3.1 Printhead

The printhead is a static sensitive device, which can be damaged if it is touched without the necessary electrostatic discharge (ESD) precautions being taken. The ESD precautions involve the use of a grounded wrist strap and/or conductive work mat.

During installation, servicing and handling of the printhead, the printhead must be protected from electrostatic discharges. The printhead can be compared with a normal CMOS circuit and must be ESD protected accordingly to avoid later problems caused by discharges.

4.3.2 Printed circuit boards

The printed circuits boards can be damaged if they, or the connectors connected to the printed circuit board, are touched without the necessary electrostatic discharge (ESD) precautions being taken. The ESD precautions involve the use of a grounded wrist strap and/or antistatic work mat.

During installation, servicing and handling of a printed circuit board it must be protected from electrostatic discharges.

4.4 Ink and cleaner

4.4.1 General safety measures

Common:

- Use the printer only in a well ventilated area.
- Do not eat or drink while working with the ink or cleaner.
- Do not smoke in the vicinity of ink, cleaner or coding unit.

When at risk for contact with the ink or cleaner:

- Wear chemical resistant gloves.
- Use safety goggles or face shield in case of splash risk.
- Wear suitable protective clothing as protection against splashing or contamination with ink or cleaner.



4.4.2 First aid measures

The first aid measures depend on the ink used in the system and are described in the corresponding SDS of the ink and cleaner. The SDS can be downloaded from the Kortho website (www.kortho.com).

4.4.3 Warning labels

The labels on the ink bottle and the cleaner bottle are warning labels.

'Warning' indicates that harm to the user or damage to the printer is possible when the user is neglecting the risk and safety phrases. The user can be exposed to (severe) injury.

4.4.4 Caution labels

The label on the ink reservoir (Fig. 4.4) is a 'Caution' labels. 'Caution' indicates that, when the user is neglecting the procedures, the coding unit is at risk of damage.

Use only the Kortho GJ ink type that is noted on the ink reservoir (Fig. 4.4), this because other ink is probably not chemical compatible with the materials used in the GraphicJet X-series and the ink that is already present in the ink reservoir. Due to the use of other inks the coding unit can develop leakage and/or the printhead nozzles can become clogged.

Refill the ink reservoir only if the low ink indicator on the control panel is lit. Refill with up to 200 ml ink (Fig. 4.4). Absolutely no more than 200ml, otherwise there is a chance the ink reservoir will overflow and/or the printhead will start bleeding.

The user has to apply the sticker of the type of ink used.

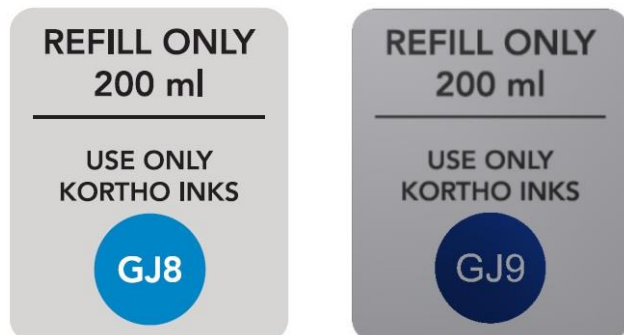

Fig. 4.4 Ink reservoir label, ink type GJ8 and GJ9 (as example).

5 TRANSPORT & STORAGE

5.1 Printer equipment

5.1.1 Shipping and handling

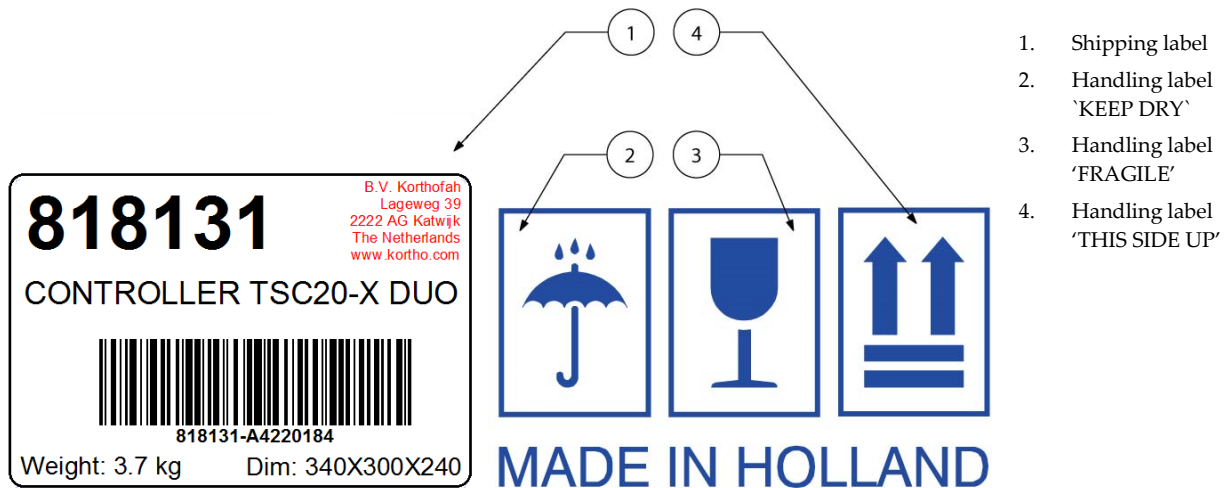

Fig. 5.1 Shipping and handling labels

The original packaging for the GraphicJet printer set is labelled with similar shipping and handling labels as shown in Fig. 5.1. The handling labels must be visible from all sides.

- Refer to label (1) of Fig. 5.1 for shipping information.

Description	Part nr.	Weight (kg)	Dimensions (cm)
Control unit TsC20-X	817807	4,7	W34xL41xH39
Control unit TsC20-X duo	818131	4,7	W34xL41xH39
Coding unit X18	817752	5,4	W25xL49xH20
Coding unit X18+	818157	5,4	W25xL49xH20
Coding unit X18si	818227	5,4	W25xL49xH20
Coding unit X54	817555	6,3	W25xL49xH20
Coding unit X72	819041	7,75	W30xL38xH28

- Store the package in a dry location, refer to label (2) of Fig. 5.1.
- Handle the package with care, because the printhead is fragile. Refer to label (3) of Fig. 5.1.
- Keep the package upright in all cases, refer to label (4) of Fig. 5.1.

5.1.2 Pre-transport procedure

The transport distance and time is determinative for the pre-transport procedure:

For movement within a building:

- Keep the coding unit upright to avoid ink leakage from the ink reservoir through the air supply/release channel.

Avoid shocks and vibrations during the transport to reduce the risk of generating air bubbles in the printhead or in the ink tubing. In this case, you have to prime the printhead and ink tubes at the new location.

For short distance and at the most two day travel:

1. Take the ink out of the ink reservoir. Extract the ink up from the ink reservoir with a clean syringe or prime all the ink through the printhead in a clean ink bottle (for later refill). Refer to subsection 8.5.2.
2. Keep the coding unit upright to avoid ink leakage of residue fluid from the ink reservoir through the air supply/release channel.
3. Use original or equal packaging for the printer equipment.
4. Label the box with 'keep dry' labels like label (B) of Fig. 5.1 (visible at all sides).
5. Label the box with 'fragile' labels like label (C) of Fig. 5.1 (visible at all sides).
6. Mark the top of the box with 'this side up' labels like label (D) of Fig. 5.1 (visible at all sides).

For long distance or at least two day travel:

1. Take the ink out of the ink reservoir. Extract the ink up from the ink reservoir with a clean syringe or prime all the ink through the printhead in a clean ink bottle (for later refill). Refer to subsection 8.5.2.
2. Refill the ink reservoir with 50ml cleaner.
3. Carry out the nozzle maintenance procedure. Refer to subsection 10.2.
4. Prime the ink system with the cleaner through the printhead in a waste container.
5. Repeat from instruction 2 until all the printhead nozzles spout a clean jet.
6. Extract or prime the remaining cleaner from the ink reservoir (same as instruction 1 but read cleaner instead of ink).
7. Verify whether the ink reservoir is empty.
8. Keep the coding unit upright to avoid leakage of residue fluid from the ink reservoir through the air release channel.
9. Use original or equal packaging for the printer equipment.
10. Label the box with 'keep dry' labels like label (B) of Fig. 5.1 (visible at all sides).
11. Label the box with 'fragile' labels like label (C) of Fig. 5.1 (visible at all sides).
12. Mark the top of the box with 'this side up' labels like label (D) of Fig. 5.1 (visible at all sides).

5.1.3 Pre-storage procedure

The printer storage location and time is determinative for the pre-storage procedure:

When still mounted on the support but idle for at least one month:

1. Take the ink out of the ink reservoir. Extract the ink up from the ink reservoir with a clean syringe or prime all the ink through the printhead in a clean ink bottle (for later refill). Refer to subsection 8.5.2.
2. Refill the ink reservoir with 50ml cleaner.
3. Carry out the nozzle maintenance procedure. Refer to chapter 10.2.
4. Prime the ink system with the cleaner through the printhead in a waste container.
5. Repeat from instruction 2 until all the printhead nozzles spout a clean jet.
6. Extract or prime the remaining cleaner from the ink reservoir (same as instruction 1 but read cleaner instead of ink).
7. Verify whether the ink reservoir is empty.
8. Place a dust cover or bag over the coding unit.

For storage prior to distribution:

1. Take the ink out of the ink reservoir. Extract the ink up from the ink reservoir with a clean syringe or prime all the ink through the printhead in a clean ink bottle (for later refill). Refer to subsection 8.5.2.
2. Refill the ink reservoir with 50ml cleaner.
3. Carry out the nozzle maintenance procedure. Refer to chapter 10.2.
4. Prime the ink system with the cleaner through the printhead in a waste container.
5. Repeat from instruction 2 until all the printhead nozzles spout with a clean jet
6. Extract or prime the remaining cleaner from the ink reservoir (same as instruction 1 but read cleaner instead of ink).
7. Verify whether the ink reservoir is empty.
8. Open de printhead housing. Refer to chapter 10.4.2.
9. Disconnect the ink filter at the ink reservoir side by turning the couplings anti-clockwise.
10. Block the ink tube at the reservoir side with a special stop (female).
11. Fill a clean syringe with oilbased cleaner (even is one uses solvent based inks).
12. Connect the syringe to the filter and fill the filter and printhead with cleaner.
13. Disconnect the syringe and block the filter with a special stop (male).
14. Close the printhead housing. Refer to chapter 10.4.3.
15. Place the coding unit in upright position in a packaging box to avoid leakage from the ink reservoir through the air release channel.
16. Use original or equal packaging for the printer equipment.
17. Label the box with 'keep dry' labels like label (B) of Fig. 5.1 (visible at all sides).
18. Label the box with 'fragile' labels like label (C) of Fig. 5.1 (visible at all sides).
19. Mark the top of the box with 'this side up' labels like label (D) of Fig. 5.1 (visible at all sides).
20. Store the printer, in the original packaging with topside upwards, in a dry place at ambient temperature between 5 °C and 40 °C.



Beware:

When re-installing the printer it is important that the ink tube from the reservoir is reconnected to the filter.



CAUTION:

When using solvent based inks, it is important to flush the filter and printhead with the cleaner for the specific solvent based ink used before reconnecting the ink tube from the reservoir to the filter.

5.2 Ink and cleaner

Refer to the latest Safety Datasheet for more detailed and accurate information.

The regulations relating to storage premises also apply to workshops where the product is handled.

5.2.1 Handling and storage

Handling : As with all chemicals, good industrial hygiene practices should be followed when handling this material. Wear appropriate protective equipment when handling this material (see Section 8 of the SDS). Always wash hands thoroughly after handling and before eating, drinking, or using tobacco products.

Avoid inhalation of ink and cleaner. Ink and cleaner may be harmful if swallowed.

Storage : Keep in a dry and cool place.

Specific use(s) : Use only as a marking tool to identify products.

As various inks and cleaners can be used in de the GaphicJet X-series, please refer to the specific Safety Datasheet of the ink/cleaner used for more detailed and accurate information.

5.2.2 Transport information

Refer to the latest Safety Datasheet for more detailed and accurate information.

Keep the ink bottle and cleaner bottle tightly closed in a dry place, between 5 °C and 40 °C, and away from strong, oxidizing agents. This is valid for all kind of transport.

6 INSTALLATION

6.1 Requirements

6.1.1 Provided by the customer

- Power: 100 - 240VAC, 50/60Hz, 85VA - including clean protective earth.
- The electrical circuit to which the printer is connected must be equipped with a 30mA residual current device (RCD).
- A print request-signal (e.g. output of the host machine or a photocell signal).
- Sufficient space for installation and operation.

Optional:

- An error input on the host machine. This will stop the host machine when the printer reports an error (general printer alarm).
- A warning-signal input on the host machine (warning alarm).
- A busy-signal input on the host machine. So the host machine can detect that the printer is in a print cycle (printer busy).
- A ready-input on the host machine, so the host machine can detect whether the printer is ready to make a print.



Note:

Refer to Appendix D, Connections, for the connection options.

6.1.2 Equipment

- Coding unit, see section 6.2.1.
- Control unit, see section 6.2.2.

6.1.3 Optional parts

- Encoder.
- Standard interface cable.
- Alarm beacon.
- Extra support parts: shaft, clamp, pole and mounting block.
- Photocell to generate print request.
- Photocell to detect the product in case of BCD label selection.
- Ethernet cable.
- Serial, RS232, cable.
- BCD cable.

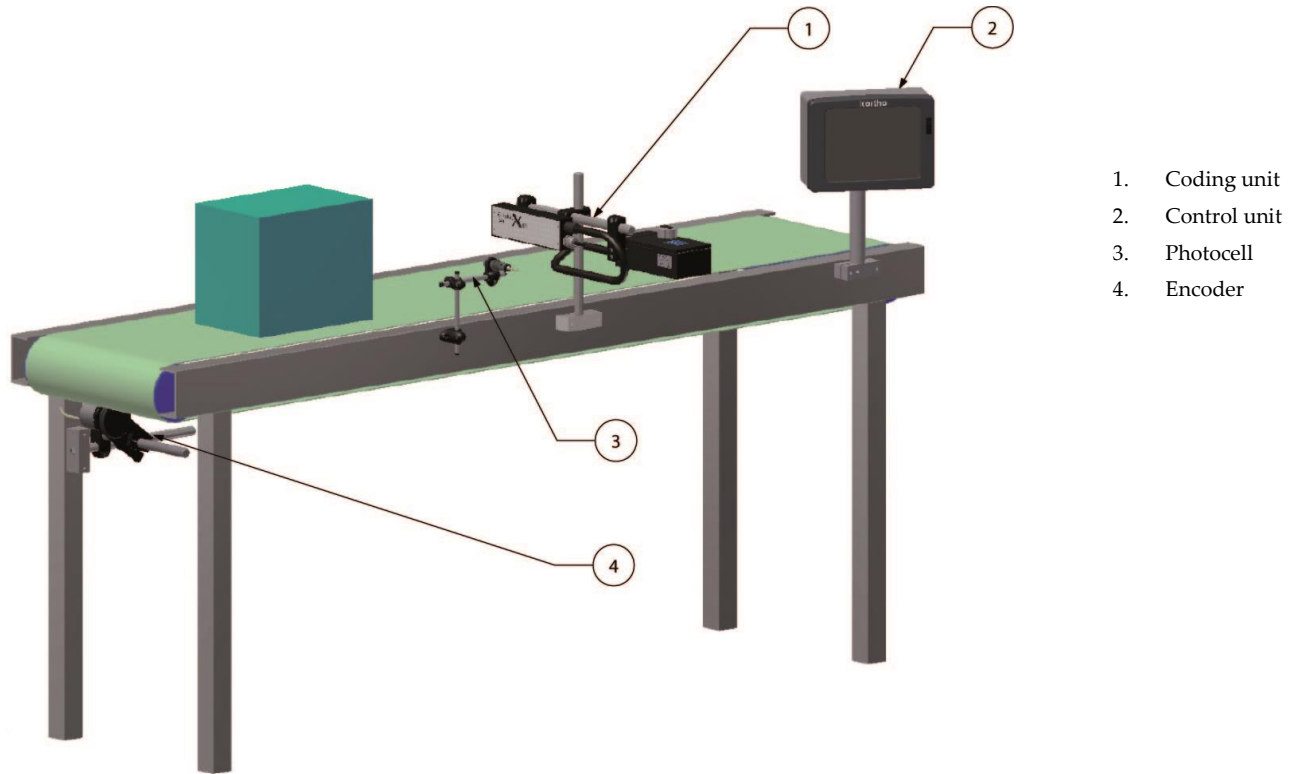

Fig. 6.1 Typical printer application

6.2 Unpacking

6.2.1 Coding unit

The coding unit consist of three main parts, the Inksystem that holds the ink used for printing, the printhead that makes the actual print and the support set.

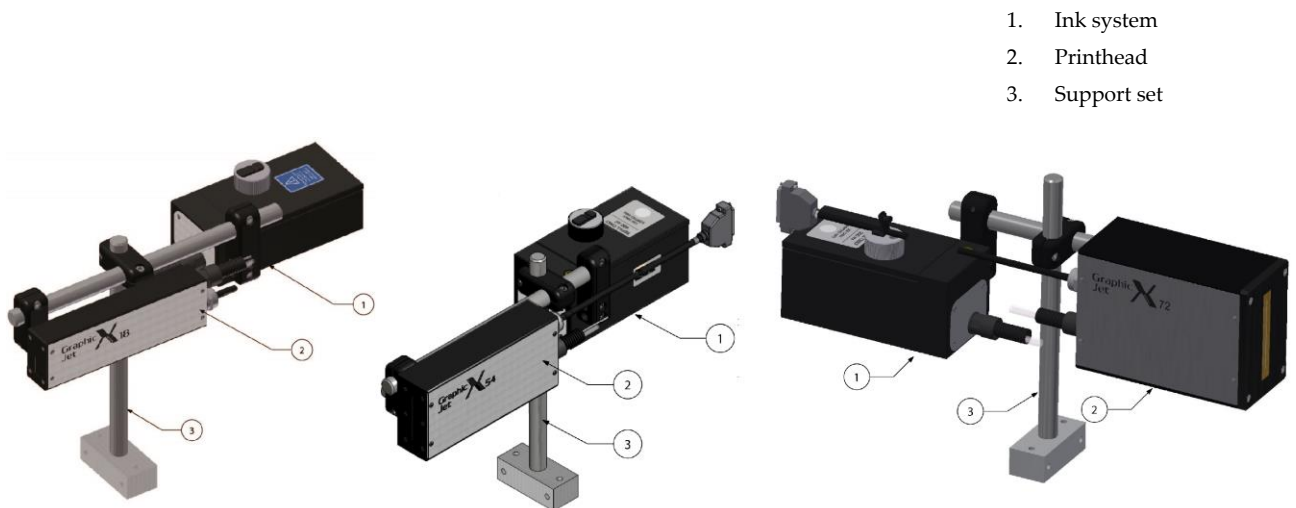

Fig. 6.2 Coding units X-series

6.2.2 Control unit

The control unit is used for controlling the coding unit and designing the labels. The control unit is equipped with an integrated bracket on the back of the control unit. The support set is optional.



1. Control unit
2. Support set (optional)

Fig. 6.3 Control unit TsC20

6.2.3 Encoder (Optional)

The encoder is used for measuring the line speed and controlling the print speed accordingly.



1. Encoder support
2. Encoder

Fig. 6.4 Encoder with support

6.2.4 Ink set

The standard ink set consists of:

- For oil based inks: two (2) bottles with 200ml Kortho ink.
- For solvent based inks: four (4) bottles with 100ml Kortho ink.
- Five (5) pair protection gloves.
- Handling instruction.

6.3 Coding unit mounting options

6.3.1 Distance between front plate and product

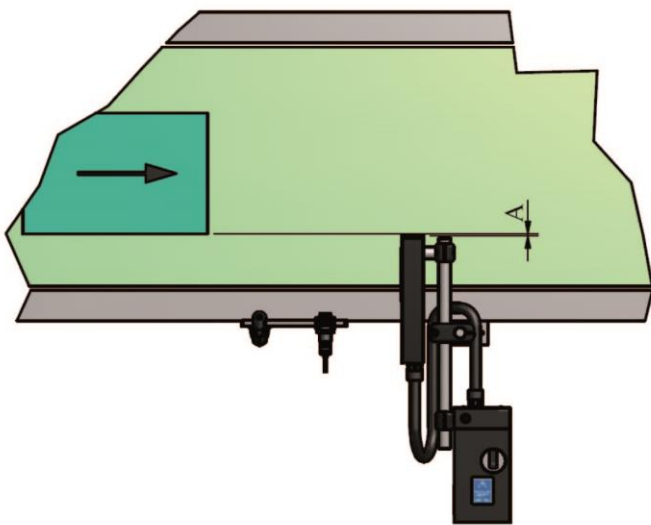

Fig. 6.5 Distance between front plate and product

The maximum print distance, distance A in Fig. 6.5, is 5 mm. If the situation permits, keep the print distance as small as possible for an optimum print quality.

Take precautions so that the product cannot damage the printhead enclosure or front plate.



CAUTION:

Make sure the location of the installation does not prevent people doing their job, there is sufficient light present for operating the printer and for maintenance and that the location is accessible for operating the printer and for maintenance.

6.3.2 Ink reservoir

The ink reservoir must always be mounted in a levelled position. This is easy to check with the built-in spirit leveller.

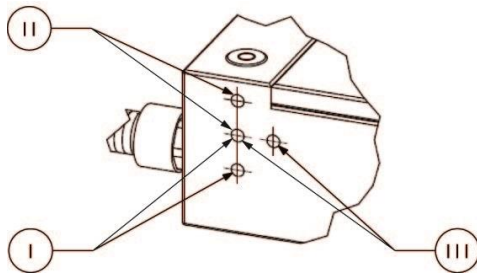

- I. Reservoir position I
(mounting-block screws fixed in the lower two holes)
- II. Reservoir position II
(mounting-block screws fixed in the upper two holes)
- III. Reservoir position III
(mounting-block screws fixed in the two horizontal holes)

Fig. 6.6 Ink reservoir mounting clamp heights

The ink reservoir mounting-clamp is standard fixed in reservoir position I. The mounting height difference between reservoir position I and II is 14 mm. When the mounting-clamp is mounted upside down on the same reservoir position, I or II, the mounting height difference is then 76 mm.

When the ink reservoir mounting-clamp is mounted in reservoir position III, the ink reservoir can be fixed at the desired height to the support pole.

The coding unit X54 is delivered including 2 ink tube clamps. These clamps should be used to connect the ink tube to the bracket. This in order to prevent vibration in the ink tube which could result in missing vertical lines in the print out and in the end de-priming of the printhead.

6.3.3 Ink reservoir orientation

The ink reservoir mounting-clamp can be fixed in two orientations, so that the ink reservoir is placed parallel or perpendicular to the support shaft. This is not possible for reservoir position III.

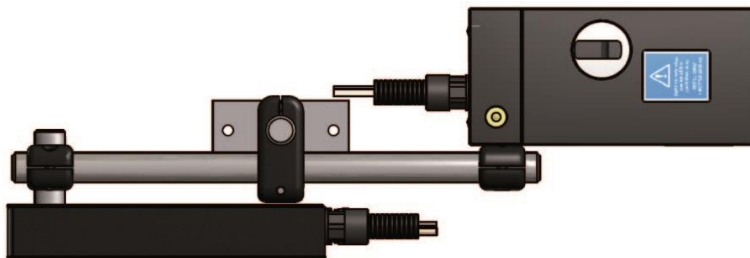

Fig. 6.7 Parallel reservoir

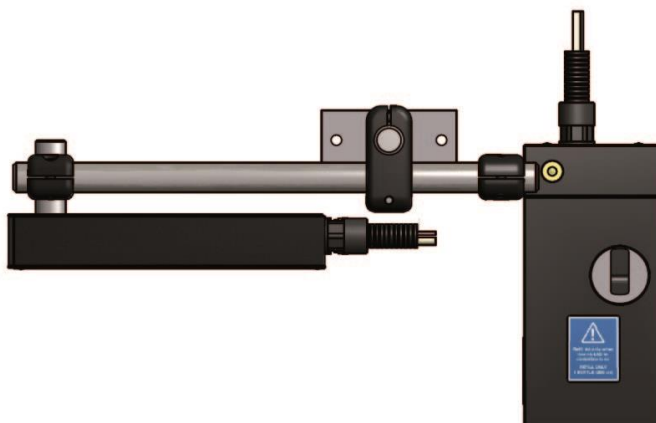

Fig. 6.8 Perpendicular reservoir

6.3.4 Printhead rotation [X54] [X72]

A rotation of the printhead means that the ink level related to the printhead will change. For proper functioning of the printhead, the ink level must be kept between the specifications as explained in section 3.3. A quick and simple way to achieve this is the use of the graphs as described in this chapter.

The dimensions and graphs are based on the type of clamps and shafts as used in the standard support set.

For every axial or radial rotation angle of the printhead, the ink reservoir must be set at a specific height. For easy measurement, the height between the top of the ink reservoir and top of the pole clamp is used. It is important that the support pole is levelled (use the built-in spirit leveller of the ink reservoir).

The top of the pole clamp is called datum-A and the top of the ink reservoir is called datum-B. The height-AB dimension is negative if datum-A is above datum-B, see Fig. 6.10.

To set the proper ink level of the coding unit for an axial or radial printhead rotation:

1. Rotate the printhead housing so that the plane of the front-plate is positioned parallel to the substrate and perpendicular to the direction of the product.
2. Position the printhead housing at the desired print position. Datum-A is now fixed.
3. Determine with the figures in subsection 6.3.5 and 6.3.6 the type of printhead rotation, either radial or axial
4. Measure or set the rotation angle (β) with a protractor or a carpenter's square for right angles. The rotation angle (β) is 0° when the printhead housing is levelled.
5. Look in the rotation graph, Fig. 6.13 or Fig. 6.16, which height-AB (h_{AB}) corresponds to the measured angle (β) according to the graph-curves. Which graph-curve is chosen depends on the mounting of the printhead clamp in Fig. 6.9, either clamp down or clamp up (y_{clamp}).
6. Position the ink reservoir so that the distance between datum-A and datum-B is equal to the found height-AB. Use, if necessary, extra clamps, poles or shafts.
7. Level the ink reservoir.
8. Check the height-AB.

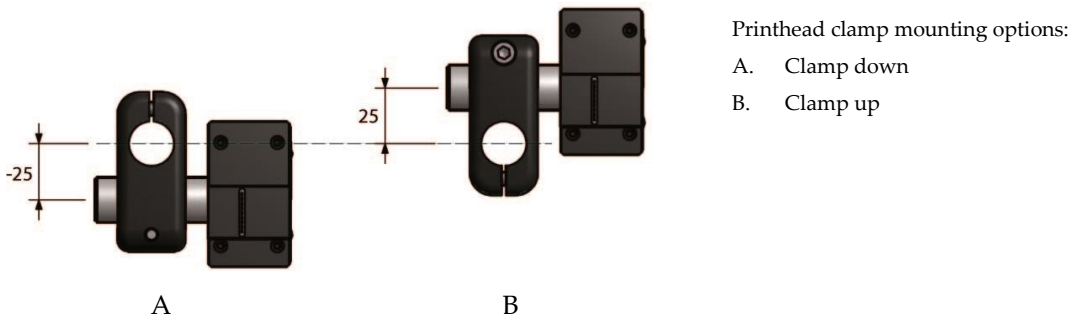

Fig. 6.9 Printhead clamp mounting options

Printhead clamp down $\Rightarrow y_{clamp} = -25 \text{ mm}$

Printhead clamp up $\Rightarrow y_{clamp} = +25 \text{ mm}$

6.3.5 Radial printhead rotation

The figures

Fig. 6.10 to Fig. 6.12 shows some examples with a radial rotation of the printhead. To change the position of the ink reservoir, refer to subsection 6.3.2.

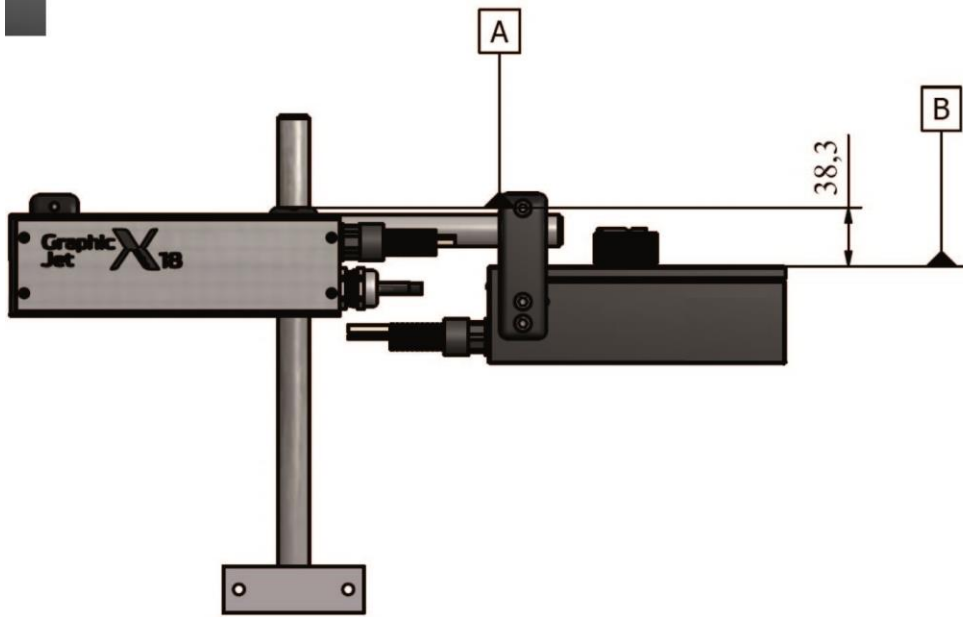

Fig. 6.10 Printhead radial rotation 0°, standard support, clamp down, reservoir position I

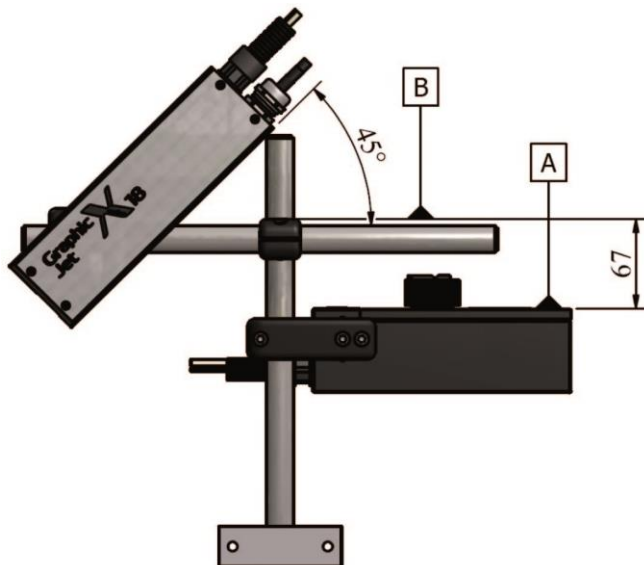

Fig. 6.11 Printhead radial rotation 45°, standard support, clamp down, reservoir position III

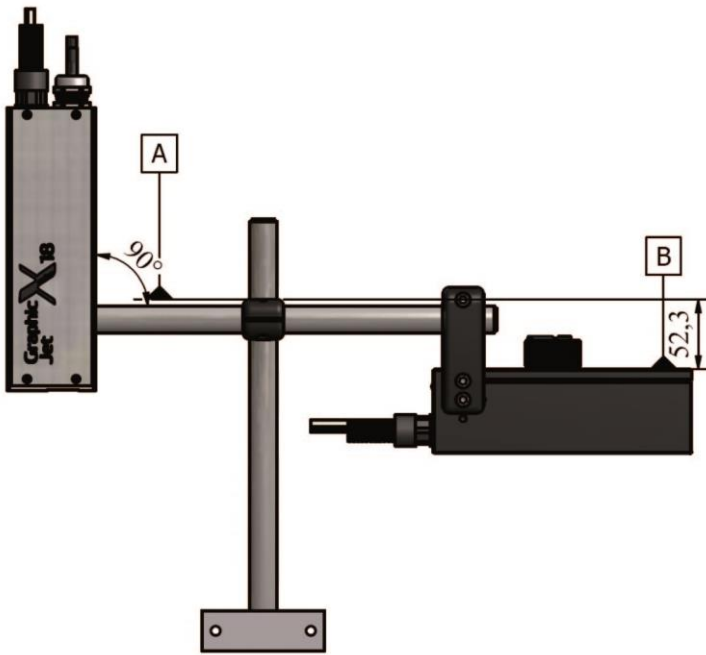

Fig. 6.12 Printhead radial rotation 90°, standard support, clamp down, reservoir position II



CAUTION:

The graph and calculation below do NOT apply to the X54 and X72. It is recommended to use the X54 and X72 only in the horizontal or vertical position, see

Fig. 6.10 and Fig. 6.12.

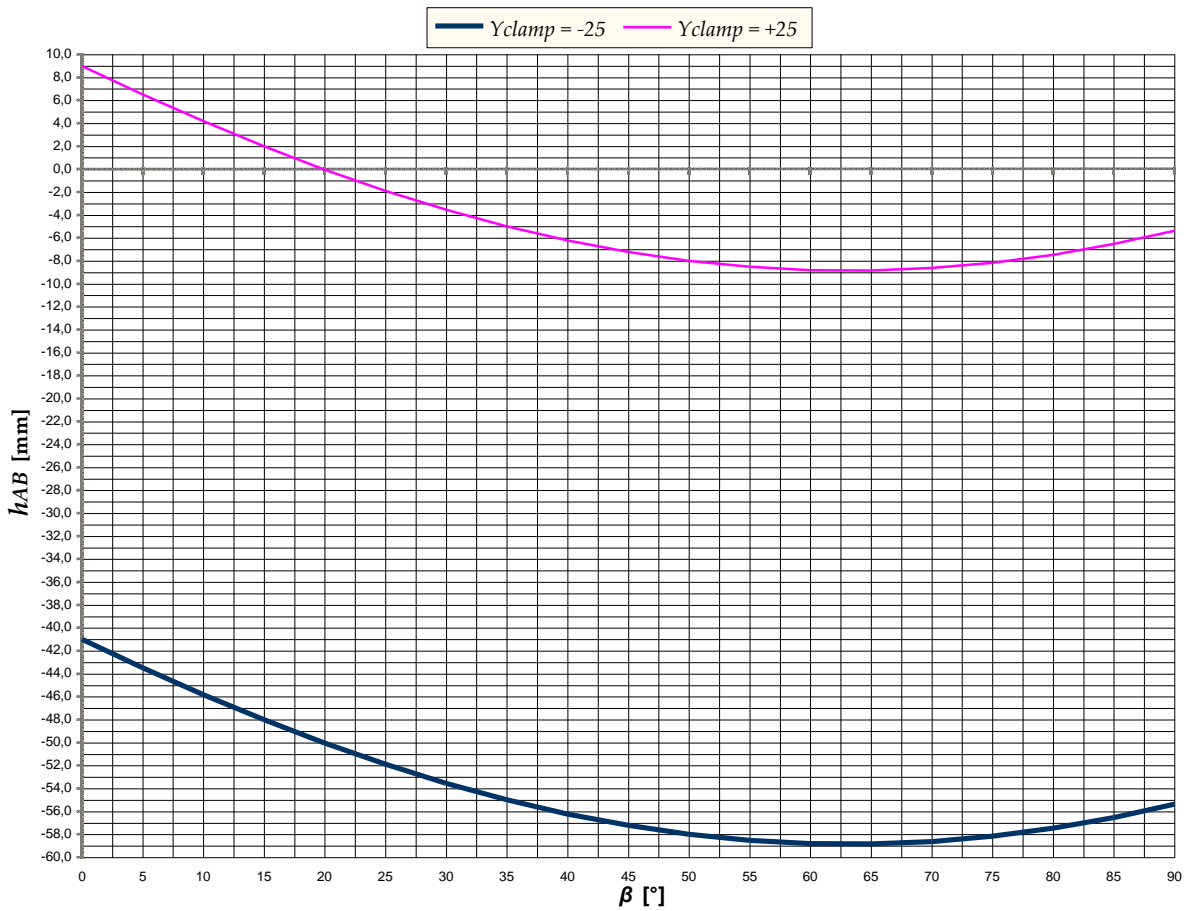

Fig. 6.13 Printhead radial rotation graph

INSTALLATION

Example [

Fig. 6.10]: Radial rotation of 0° , printhead clamp down, height-AB = -41.0 mm

Example [Fig. 6.11]: Radial rotation of 45° , printhead clamp down, height-AB = -57.2 mm

Example [Fig. 6.12]: Radial rotation of 90° , printhead clamp down, height-AB = -55.4 mm

To calculate height-AB at a given radial rotation angle ($h_{AB(\beta)}$ [mm]), use these equations:

$0^\circ \leq \beta \leq 90^\circ$: β is the radial rotation angle of the printhead housing.

$y_{clamp} = \pm 25 \text{ mm}$: y_{clamp} is the dimension between the centrelines of the printhead housing and the support shaft. With the printhead clamp down, $y_{clamp} = -25 \text{ mm}$.

$$h_{AB(\beta)} = (y_{clamp} + 1.37) - 32.48 * \text{SIN}(26.78 + \beta)$$

6.3.6 Axial printhead rotation [X54] [X72]

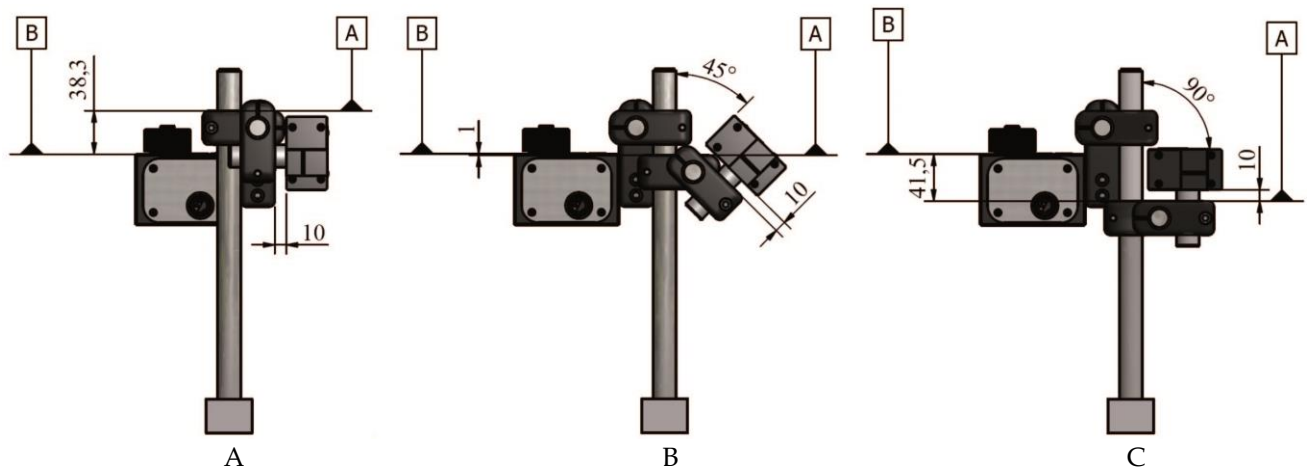

Fig. 6.14 Printhead axial rotation 0° , 45° and 90° , clamp down, reservoir position I, $x_{gap} = 10 \text{ mm}$

For some axial angles, the standard coding-unit support needs an extra shaft and pole clamp. Compare example [A] with [B] and [C] of Fig. 6.14. At some angles, the reservoir mounting clamp must be fit to reservoir position II or III instead of the standard I position (refer to

Fig. 6.6) because the two pole clamps can be in the way of each other.

First, set the x_{gap} (=10mm in Fig. 6.14). Look at the curves in the graph Fig. 6.16 for a height-AB at a given axial rotation angle. Every curve in the graph Fig. 6.16 have their own x_{gap} and y_{clamp} values.

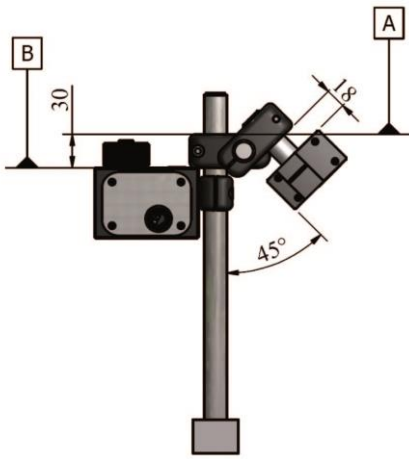

Fig. 6.15 Printhead axial rotation -45° , clamp up, reservoir position III, $x_{gap} = 18mm$

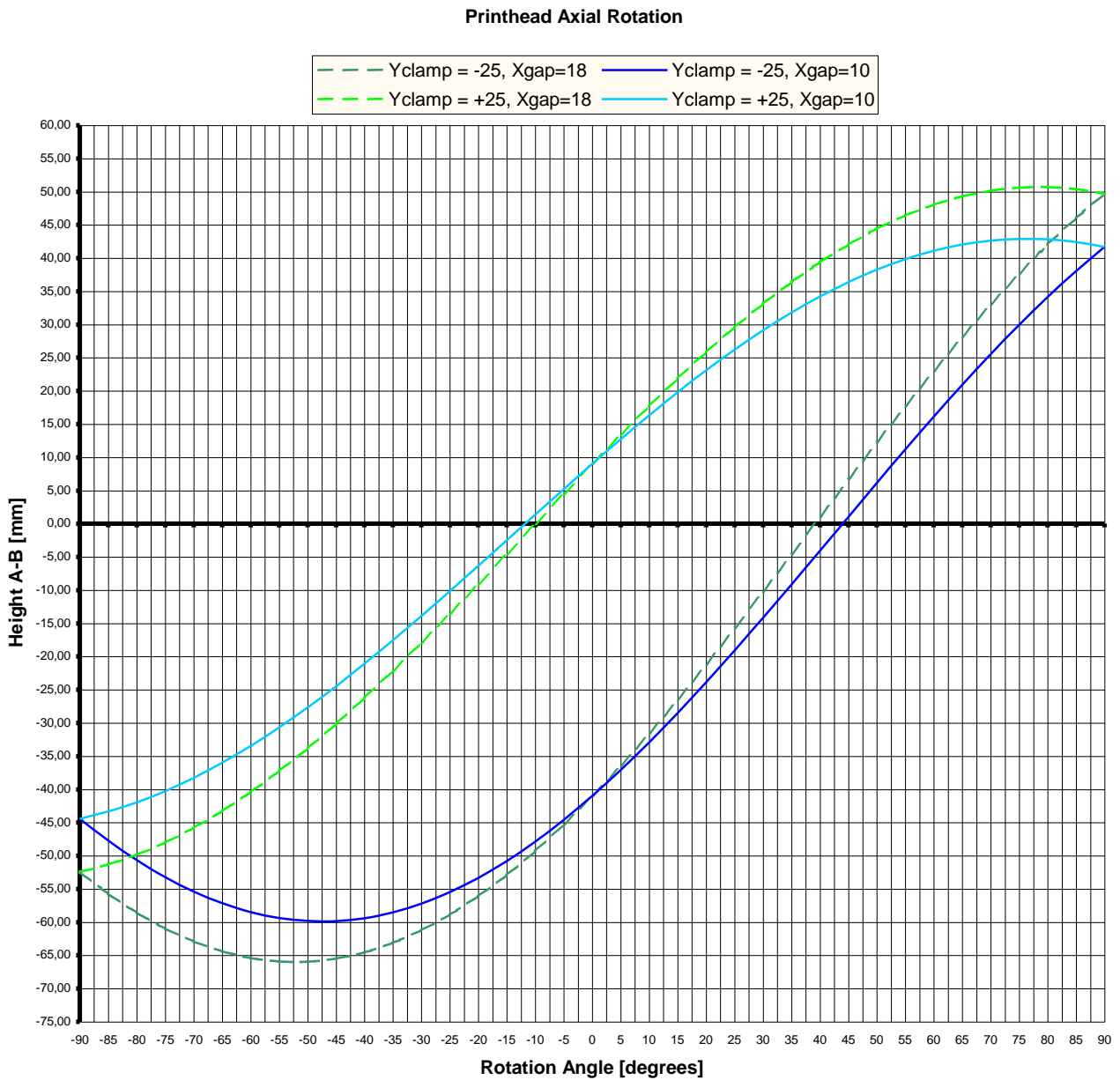

Fig. 6.16 Printhead axial rotation graph

Example [4]: Axial rotation of 0° , clamp down, $x_{gap} = 10\text{ mm}$, height-AB = -41.0 mm

INSTALLATION

Example [5]: Axial rotation of 45° , clamp down, $x_{gap} = 10 \text{ mm}$, height-AB = 1.0 mm

Example [6]: Axial rotation of 90° , clamp down, $x_{gap} = 10 \text{ mm}$, height-AB = 41.5 mm

Example [7]: Axial rotation of -45° , clamp up, $x_{gap} = 18 \text{ mm}$, height-AB = -30.0 mm

When the $x_{gap} \neq 10 \text{ or } 18 \text{ mm}$, calculate height-AB at a given rotation angle ($h_{AB(\beta)}$ [mm]) with these equations:

$-90^\circ \leq \beta \leq 90^\circ$; β is the axial rotation angle of the printhead housing.

$8.5 \text{ mm} \leq x_{gap} \leq 18 \text{ mm}$; x_{gap} is the dimension C in Fig. 6.14 and

Fig. 6.15.

$y_{clamp} = \pm 25 \text{ mm}$; y_{clamp} is the dimension between the centrelines of the printhead housing and the support shaft. With the printhead clamp down, $y_{clamp} = -25 \text{ mm}$.

$x_0 = 33.05 + x_{gap}$; horizontal dimension, at $\beta = 0^\circ$, between the first (bottom) nozzle and the printhead rotation point.

$y_0 = 14.635 - y_{clamp}$; vertical dimension, at $\beta = 0^\circ$, between the first (bottom) nozzle and the printhead rotation point.

$\alpha_0 = \text{ARCTAN}\left(\frac{y_0}{x_0}\right)$; α is the axial rotation angle of the line, at $\beta = 0^\circ$, between the first (bottom) nozzle and the printhead rotation point.

$$h_{AB(\beta)} = (y_0 + y_{clamp} - 1) - x_0 * \left(\frac{\text{SIN}(\alpha_0 - \beta)}{\text{COS}(\alpha_0)}\right)$$

6.3.7 Radial and axial printhead rotation [X54] [X72]

An application with a combined axial and radial printhead rotation is more difficult, because both graphs, Fig. 6.13 and Fig. 6.16, cannot be combined. As described in section 3.3, it is important that for any orientation of the printhead the top ink level in the reservoir is at least 3mm below the level of the first (bottom) nozzle, otherwise the printhead starts 'bleeding' ink.

The top ink level lies 16.8 mm below datum-B if the reservoir is levelled. This means that datum-B lies 13.8 mm above the first (bottom) nozzle of the printhead. The distance between first (bottom) nozzle and the bottom of the printhead housing is 15.4 mm.

To roughly set the ink level of the coding unit for an axial and radial printhead rotation:

1. Rotate the printhead housing so that the plane of the front-plate is positioned parallel to the substrate and perpendicular to the direction of the product.
2. Position the printhead housing at the desired location. Datum-A is now fixed
3. Clamp with a cramp an aid-strip, levelled at 13.8 mm below datum-B, to the ink reservoir. The topside of the aid-strip lies now 3 mm above the top ink level.
4. Position the aid-strip in the horizontal plane of the first nozzle while keeping the aid-strip and reservoir level with the build-in leveller.
5. Mark the position of the ink reservoir.
6. Mount the ink reservoir at the marked position. Use, if necessary, extra clamps, poles or shafts.
7. Check whether the ink reservoir is levelled.

8. Check with the aid-strip if the horizontal plane of the first nozzle is 13.8 mm below datum-B.



Beware:

After the first refill of the ink reservoir the printhead may start ‘bleeding’ ink. Stop this ‘bleeding’ by lowering the ink reservoir by about 1 mm.

6.4 Positioning the sensors

6.4.1 Photocell for print request (X04)

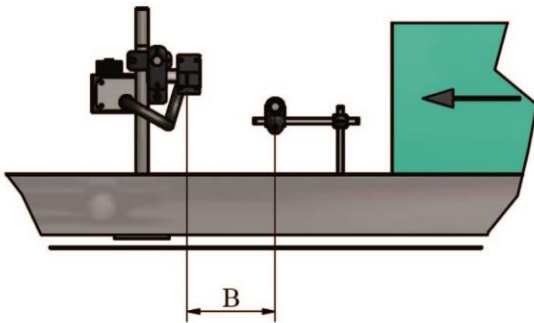

Fig. 6.17 Photocell positions (front view)

The photocell is placed at distance B ahead of the printhead (Fig. 6.17). The photocell will trigger the print request input of the printer to make a print. To print on the product, the print delay parameter (subsection 8.6.6) must be set to a value that is equal or greater than distance B, in order to print on the product.

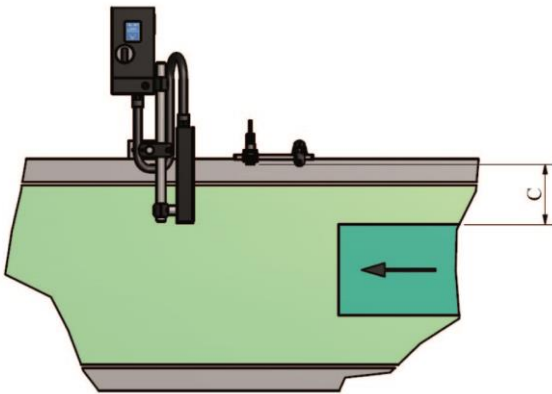

Fig. 6.18 Photocell distance to the product (top view)

Keep the photocell distance (C in Fig. 6.18) within the maximum operating range of the photocell, which is approximately 400 mm. The operating range also depends on the type of photocell (or other sensor) and product properties like colour, reflection etc.

Take precautions so that the product cannot damage the photocell.

6.4.2 Photocell to enter BCD code into the buffer (X08)

This photocell must be placed so that when the product is detected, a valid BCD code is present on the BCD input (X07). The label belonging to this BCD code is placed in a buffer. Multiple BCD codes (ie labels) can be placed in the buffer. This is completely automatic. If a product is detected by the photocell (or other sensor) to make a print, the first label is printed from the BCD buffer and after the print the next label is automatically loaded for the next product. See appendix H for the exact operation of the BCD option and see appendix D for the connection of a photocell (or other sensor) to put the BCD code for the relevant product

in the buffer. Keep the photocell distance (like shown in Fig. 6.18) within the maximum operating range of the photocell, which is approximately 400 mm. The operating range also depends on the type of photocell (or other sensor) and product properties like colour, reflection etc.

Take precautions so that the product cannot damage the photocell.

6.4.3 Encoder (optional)

To make sure the print will be made exactly at the speed the substrate is moving an encoder can be connected to the control unit. This encoder measures the substrate speed, based on which the control unit will regulate the print speed. The encoder for the X18 and X54 are the same. The encoder for the X72 is different. It supplies 5000 pulses per revolution instead of the 1800 for X18 and X54.

The diameter of the measuring wheel is also different between the X18/X54 and X72.

1. Mount the encoder in such a position that it detects the movement of the product from the moment the photocell detects the product until the print is made. Mount the encoder as close as possible to the location of the printhead to get the most accurate measurements for the best print quality.
2. Set the lever tension with the spring clamp and the lever limiter so that the encoder wheel will not slip, the product will not get damaged and the motion of the product will not get disturbed.

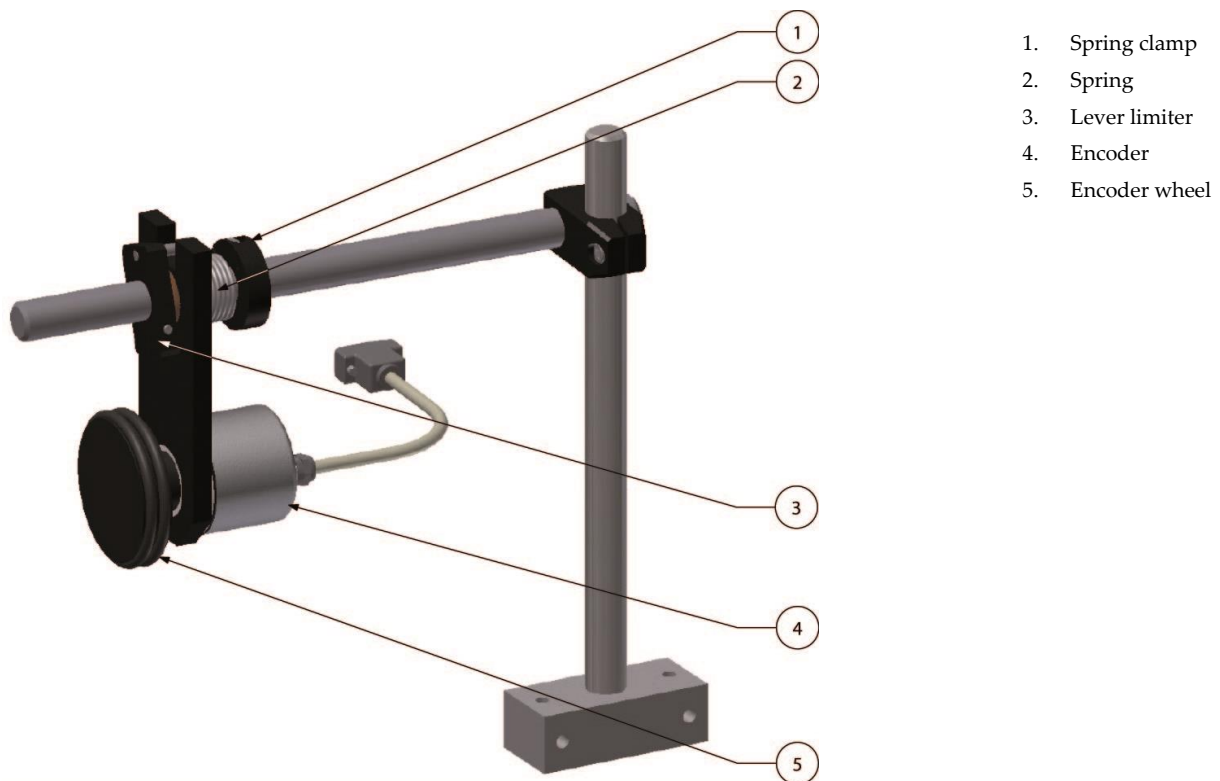

Fig. 6.19 Encoder adjustment

3. Take precautions that the product cannot damage the encoder.



Beware:

Mount the encoder as close as possible to the location of the printhead. This will give the best print results.

6.5 Mounting the control unit

1. Find a secure location, which is easily accessible for operators, to mount the control unit.
2. Locate the control unit on a position near the coding unit bracket and install the cable so that the coding unit can rotate and move back and forth within the dimensions of the bracket.
3. Check whether all of the cables mentioned below are long enough to be connected to the connectors on the bottom of the control unit. If not, correct it by relocating either the coding unit or the control unit and/or extend the cable(s) if possible (the cable between the coding unit and control unit should not be extended).
4. Mount the control unit on the determined location. Refer to Appendix B, for the dimensions of the mounting holes.
5. Connect the interface cable to the host machine. Use the electrical diagram, Appendix D X3 Circuit diagram (input) and X3 Circuit diagram (output), to determine which interface option suits best with the host machine.

**CAUTION:**

Make sure the interface cable is no longer than 30m and is shielded. Using a cable longer than 30m can cause EMC interference.

6. Connect the interface cable to the interface port (X03).
7. Connect the print request cable (X04 – e.g. photocell).
8. Connect the encoder cable (X01 - optional).
9. Connect the control/data cable, between the control unit and the coding unit (X02/X06 - fixed length).
10. Connect the LAN cable (LAN - optional).
11. Connect the BCD cable (X07 – optional).
12. Connect the RS232 cable (X05 – optional).
13. Connect the Product detect cable (X08 – optional)
14. Connect the mains supply (X09).

7 COMMISSIONING

This part describes the commissioning of a typical printer application. Make sure the printer is properly installed, see chapter 6, before starting up any action as described in this chapter. The coding unit should be connected to the control unit at all times.

7.1 Preparing the control unit

To setup the control unit for the first time:

1. Connect the mains power plug.
2. Switch on the control unit and wait until the main menu appears. The control unit will check whether the software versions of the coding unit and the control unit match. If not the software of the coding unit will be automatically updated (upgrade or downgrade).

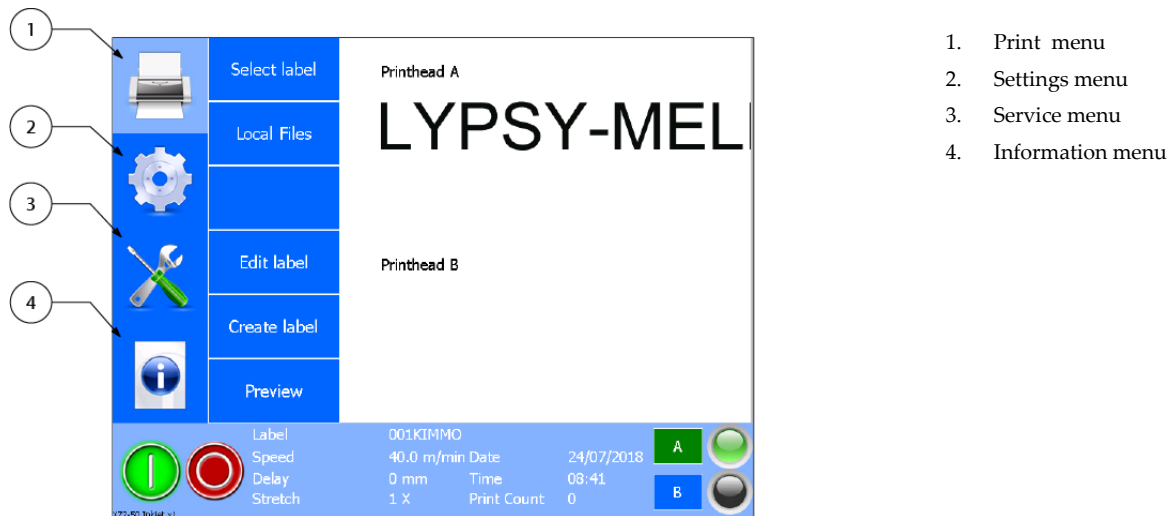

Fig. 7.1 Main menu

3. Touch the *Settings* icon.

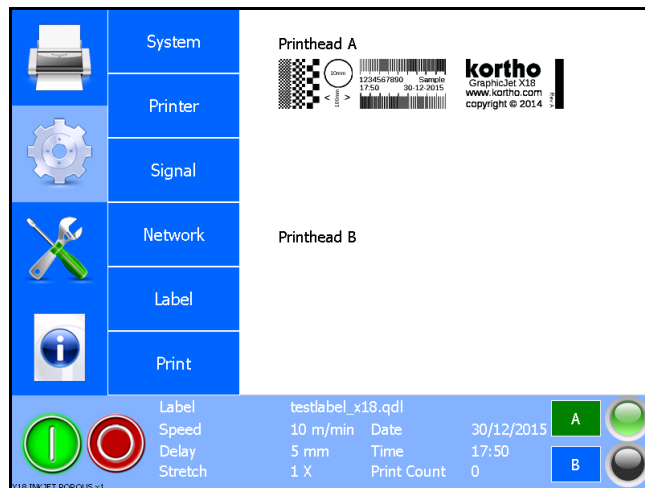

Fig. 7.2 Printer settings menu

4. Set the parameters in the System submenu, refer to section 8.6.1.
5. Set the parameters in the Printer submenu, refer to section 8.6.2.
6. Set the parameters in the Signal submenu, refer to section 8.6.3.
7. Set the parameters in the Network submenu, refer to section 8.6.4.

8. Set the parameters in the Label submenu, refer to section 8.6.5.
9. Set the parameters in the Print submenu, refer to section 8.6.6.
10. Switch off the control unit.



Beware:

If there are two coding units mounted to one controller, one must be aware of the fact that some parameters are global and that some need to be set individually for each coding unit. See section 8.7 for detailed information.

7.2 Filling the ink system



Beware:

When filling the ink system for the first time one should check the ink type to be used and apply the label with the corresponding ink code to the ink system. This in order to warn the user to only refill the system with the right type of ink.

1. Switch on the control unit.
2. Rotate, if necessary, the printhead housing to the horizontal position (Fig. 7.3). The printhead radial and axial rotation is then 0°. The height-AB for the printhead housing and the ink reservoir is not important for this procedure.

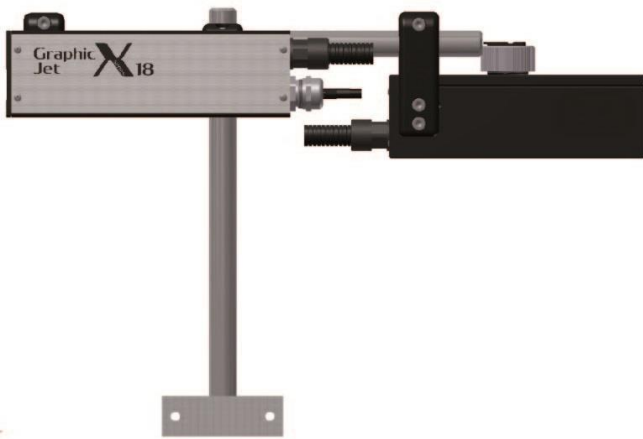

Fig. 7.3 Printhead housing at horizontal position

3. Put on protection gloves and use safety goggles for personal protection.
4. Clean and remove any dust from the top of the ink reservoir.
5. Take an ink bottle and cut off the end, which is indicated with a ring, of the spout top (Fig. 7.4).



CAUTION:

Use ONLY Kortho GJ inks in 200 ml bottles [X18 / X18+ / X54 / X72] or 100ml bottles [X18si], see also the indicator on the reservoir.



Fig. 7.4 Cut ink bottle open

6. Open the ink reservoir by unscrewing the screw cap (Fig. 7.5) counter clockwise.
7. Put the screw cap aside at a clean place.



Fig. 7.5 Ink reservoir opened.

8. Place, without spilling ink, the ink bottle upside-down into the ink reservoir fill opening.



Fig. 7.6 Ink reservoir with ink bottle placed.

9. Squeeze the ink bottle gently until it is empty. The status of the ink level indicators on the screen of the control unit is now, orange off and green on.



CAUTION:

Fill the ink reservoir with maximum ONE 200ml ink bottle [X18 / X18+ / X72], maximum TWO 200ml [X54] or maximum TWO 100ml ink bottles [X18si] ONLY. Filling with more bottles of ink will cause ink leakage at the printhead or an inkreservoir overflow.

10. Remove the empty ink bottle and avoid spilling ink. Clean the reservoir opening with a clean paper tissue.
11. Close the ink reservoir by screwing the screw cap (Fig. 7.7) back on. Hand tight is sufficient.

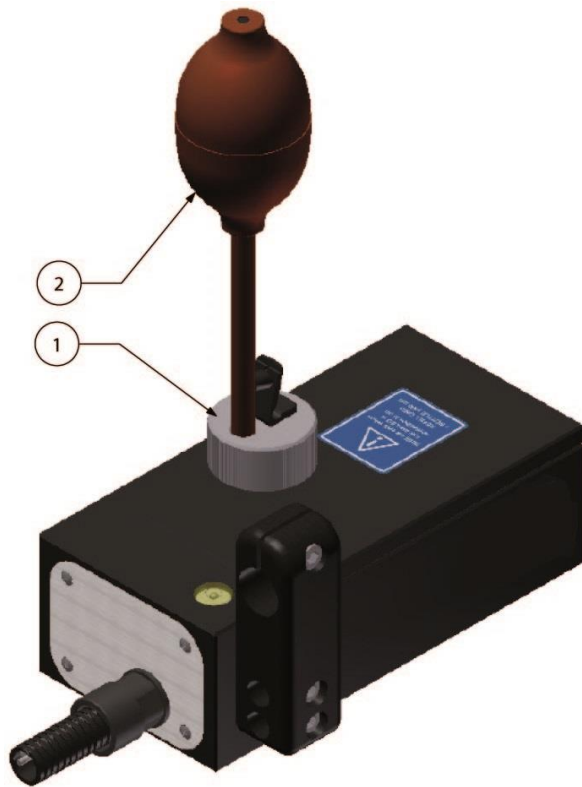

1. Screw cap
2. Prime bulb

Fig. 7.7 Ink reservoir with prime bulb.

12. Fit the prime bulb to the opening in the screw cap (Fig. 7.7).
13. Hold paper tissues in front of the printhead to collect ink.
14. Squeeze the prime bulb completely just one time to prime the printhead. Prime in bursts of about three to five seconds to remove any air bubbles out of the ink system.
15. Repeat priming until ink squirts from all the nozzles.
16. Remove the prime bulb (gently, to avoid a pressure wave within the ink tubes) from the fitting of the screw cap to stop priming the printhead.
17. Rotate the printhead housing back to the print position. This is only necessary if the printhead housing is rotated to the horizontal position at instruction 2.
18. The printer is now ready to print.

7.3 Tuning the speed related parameters

Proceed with this section only if the instructions of the sections 7.1 and 7.2 are carried out successfully.

7.3.1 Preparing for the first test print

1. Switch on the control unit.
2. Touch the *Settings* icon
3. Touch the *Signal* button (Fig. 7.8).

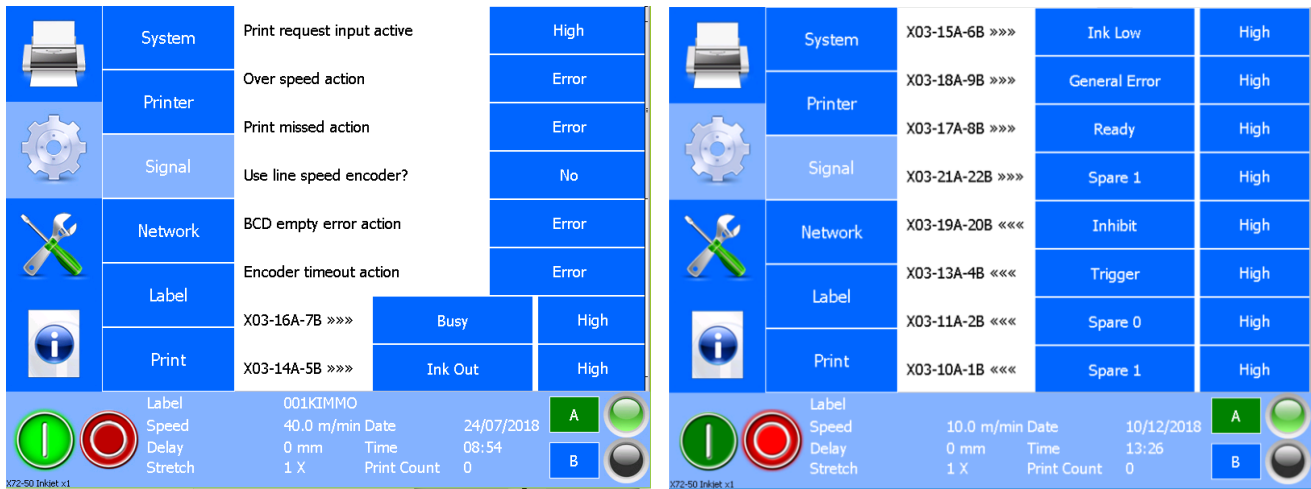

Fig. 7.8 Settings menu

4. Set the *Use line speed encoder?* setting to *No*, because the encoder will not be used in this procedure.
5. Set the printer in Pause mode by pressing the Stop button
6. Touch the *Diagnostic* icon
7. Touch the *Test labels* button (Fig. 7.9).

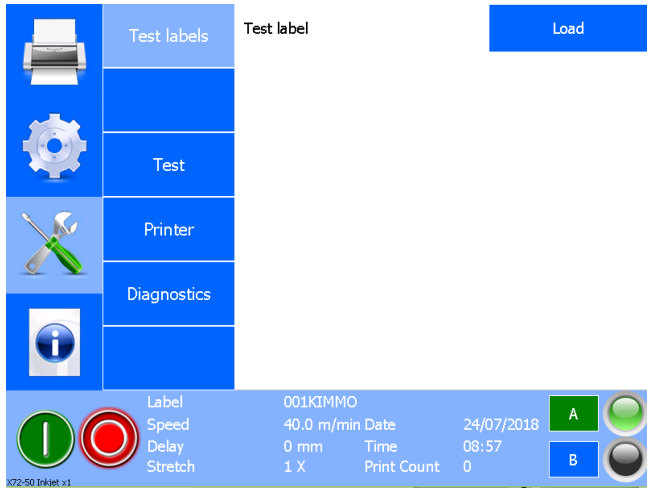

Fig. 7.9 Diagnostics – Test label menu

8. Touch *Load* button to load the *Test label* and press *Ok* on the next screen.



Beware: When two coding units are connected: Touch “A” or “B” at the right bottom corner of the screen to select Printhead A or B. The green colour indicates the selected coding unit.



Beware: If there are two coding units connected to the control unit one has to select the test label for each individual printhead.

9. Touch *Test* in the second column (third one down).

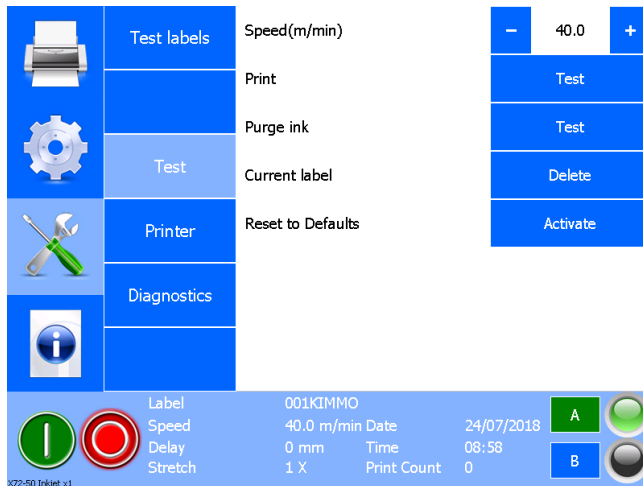

Fig. 7.10 Diagnostics – Test menu

10. Set the *Speed* to 10 m/min
11. Place a piece of paper or something similar in front of the printhead.
12. Touch the *Test* button (behind *Print*) to make a sample print and move the piece of paper along the printhead at the same time.
13. Check whether a test print is made. The test print is probably not readable but this is not important yet, this test is only to check whether the printhead prints. If the test failed, refer to chapter 9.
14. Check whether the detection indicator of the photocell will be lit when moving the product at operational distance along the front of the photocell.
15. Adjust the detection sensitivity of the photocell if necessary.
16. Proceed, depending if an encoder is used, with either subsection 7.3.2 or 7.3.3.

7.3.2 Tuning the test print with the encoder disabled

Proceed with this subsection only if the instructions of the subsection 7.3.1 are successfully carried out.

1. Touch *Setting* icon.
2. Touch the *Signal* button
3. Set the *Use encoder* setting to *No*.
4. Touch the *Print* button.
5. Set the *Speed* to the estimated speed of the substrate.
6. Set the *Print delay* to the value of the distance between the photocell and the printhead, refer to Fig. 6.17 dimension B. The delay value is in millimetres at the correct speed setting.
7. Remove all the tools and loose materials from the host machine and start the host machine.
8. Move a sample product along the photocell and the printhead. A test print (Fig. 7.11) should be made on the sample product.
9. Check whether the complete test print is made on the sample product. The test print may be mirrored but this is not relevant for this procedure:
 - a. If the begin of the test print is missing, increase the delay parameter or reposition the photocell closer to the printhead housing.
 - b. If the overall length of the test print is shorter than 100 mm (175mm for X72), decrease the speed parameter.
 - c. If the overall length of the test print is longer than 100 mm (175mm for X72), increase the speed parameter.
 - d. If the end of the test print is missing, decrease the delay parameter or use a longer sample product.



Fig. 7.11 Test label printed at correct speed setting (X18)

10. Repeat the instructions 8 and 9 until the test label is printed on the correct position of the product with a length of 100 mm (175mm for X72).

7.3.3 Tuning the test print with the encoder enabled

Proceed with this subsection only if the instructions of the subsection 7.3.1 are successfully carried out.

1. Touch the *Setting* icon.
2. Touch the *Signal* button
3. Set the *Use encoder* setting to *Yes*.
4. Touch the *Print* button.
5. Set the *Print delay* to the value of the distance between the photocell and the printhead, refer to Fig. 6.17 dimension B. The delay value is in millimetres.
6. Remove all the tools and loose materials from the host machine and start the host machine.
7. Check whether the encoder wheel turns and does not slip
8. Move a sample product along the photocell and the printhead. A test print (Fig. 7.12) should be made on the sample product.



Fig. 7.12 Test label printed

9. Check whether the complete test print is made on the sample product. The test print may be mirrored, but this is not relevant for this procedure.
 - a. If the begin of the test print is missing, increase the delay parameter or reposition the photocell closer to the printhead housing.
 - b. If the overall length of the test print is not equal to 100 mm (175mm for X72), check whether the encoder isn't slipping or bouncing.
 - c. If the end of the test print is missing, decrease the delay parameter or use a longer sample product.
10. Repeat the instructions 9 and 10 until the test label is printed on the correct position of the product.

7.4 General print parameter settings

Proceed with this section only if the instructions of section 7.3 are successfully carried out. The parameters in this section are not described in any particular order.

7.4.1 Changing the print direction

1. Make a test print with the test label.
2. Check whether the test print is mirrored (Fig. 7.13). If not, no further action is required.

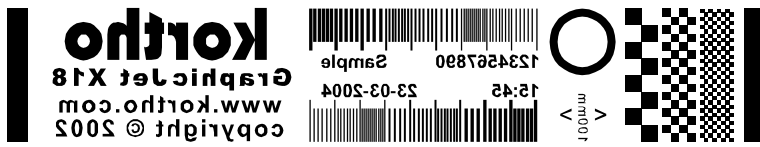

Fig. 7.13 Test label printed mirrored

3. Touch the *Settings* icon.
4. Touch the *Label* button.
5. Set the *Orientation* from *Normal* to *Mirror*.

**Beware:**

If there are two coding units connected to the control unit one has to perform the steps above for each individual coding unit.

**Beware:**

If a Coding unit X54 / X72 is connected to the controller one should also make sure the Product direction setting in the Printer settings menu is set to the correct value for optimum print quality, see section 8.6.2.

7.4.2 Changing the print direction and mirroring the label

1. Make a test print with the test label.
2. Check whether the test print should be printed upside-down (Fig. 7.14). If not, no further action is required.



Fig. 7.14 Test label printed upside-down

3. Touch the *Settings* icon.
4. Touch the *Label* button.
5. Set the *Orientation* from *Normal* to *180 degrees* or from *Mirror* to *Mirror + 180 degrees*.

**Beware:**

If there are two coding units connected to one controller, one should set these parameters for each individual coding unit, see also section 8.7.

7.4.3 Setting the print request parameters

The Print input parameter defines what kind of trigger signal, from the photocell or host control, is recognised by the printer. The options are High or Low. Beside this there is a Continuous print option.

The polarities refer to the rising (High) or falling (Low) edge of the trigger (print request) signal. Continuous print means that after each print cycle, the next print cycle is started automatically as long as the trigger signal is activated.

**Note:**

At a continuous print request setting, the delay parameter can be used to define the distance between each print.

Setting the Print request

1. Touch the *Settings* icon.
2. Touch the *Signal* button.
3. Set the *Print request input* to *High* or *Low*.

Setting the Continuous print option

1. Touch the *Settings* icon.
2. Touch the *Printer* button.
3. Set *Continuous print* to *Yes* or *No*.

Setting the Print debounce

Use the Print debounce menu to set a time-period that the print request must be continuously active before accepting the print request. Use it to suppress any switching transients on the print request signal. In most circumstances a setting at 50ms will do when a mechanical switch is used. The default setting of 10ms will do fine when using a photocell (solid state sensor).

1. Touch the *Settings* icon.
2. Touch the *Print* menu.
3. Set the *Debounce* to the required value.

7.5 Spit parameter settings

7.5.1 Setting the spit parameters

**Beware:**

If there are two coding units connected to one controller, one should set these parameters for each individual coding unit, see also section 8.7.

Spit function

Spitting means that the printhead will print pixel-columns at predefined intervals. Spitting is suppressed while printing a label.

For the GraphicJet X-series installations using oilbased ink, it will, for the majority of the installations not be necessary to use the spit function. Consult the distributor when the use of the spit function is considered.

For the GraphicJet X-series installations using solvent based ink, it might be necessary to use the spit function. This as solvent based inks will not only dry on the substrate but also on the nozzle plate and in to the printhead nozzles. The drying of the ink on the nozzle plate can block to nozzles over time. To avoid this kind of blocking, it can help if the printhead is printing pixel-columns (spitting) at predefined intervals.

The disadvantages of using printhead spitting are:

- Pollution of the direct surroundings.
- Waste of ink.

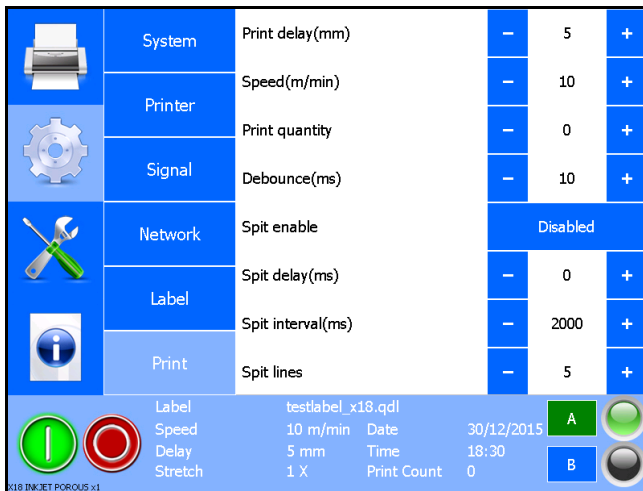

Fig. 7.15 Settings - Print menu

Spit Enable

To set the spit function the function needs to be enabled. To set the Spit function:

1. Touch the *Settings* icon.
2. Touch the *Print* button.
3. Set *Spit enable* to Enabled

Spit delay

Set the Spit delay, to prevent pixel-columns being spit on the product. This spit delay represents the time in seconds that the system will wait after a label has been printed, before starting to spit.

The spit delay can be set to a value between 0 and 20.000 milliseconds. When zero is selected, the first pixel-column will be spit directly after the printed label. Determine how long it will take the product to pass the printhead after it has printed the label. Select this value in the menu above and see whether this value is correct. If it does not matter that the pixel-column is spitted on the product, just leave the value at zero. To set the spit delay:

1. Touch the *Settings* icon.
2. Touch the *Print* menu.
3. Set *Spit delay(ms)* to the required value

Spit interval

When the value is set to 2000, the printhead will 'spit' a pixel-column every 2 seconds of 128 dots of ink (382 dots for X54 and 510 dots for X72) every 'x' (x= set value) seconds. The range off the spit interval can be set between 2.000 and 20.000 milliseconds. The set interval time depends on the type of ink used and ambient circumstances, like temperature and humidity. Try several settings to minimise ink usage and pollution. To set the Spit interval:

1. Touch the *Settings* icon.
2. Touch the *Print* button.
3. Set *Spit interval(ms)* to the required value

The first pixel-column will be spitted directly after the print cycle has finished. To avoid these pixel-columns being printed on the product, use the option Spit delay to set a time, which the printer will take into account before the pixel-column will be spit.

Spit lines

The amount of lines that will be spitted every set interval can be set between 1 and 5. To set the amount of lines:

1. Touch the *Settings* icon.
2. Touch the *Print* menu.
3. Set *Spit lines* to the required value

7.5.2 Setting the ink low and ink out outputs

**Beware:**

If there are two coding units connected to one controller, one should set these parameters for each individual coding unit, see also section 8.7.

The Low ink prints setting tells the printer what to do when the ink level in the ink reservoir is low. At ink low condition, the printer will generate a warning on screen, will activate the ink low output and will continue to print for the amount of prints set. After the set amount of prints is reached the printer stops printing and the Ink out output will be set.

**CAUTION:**

If the Low ink prints is set to a relatively high value, there is an apparent risk that air is able to enter the ink tubing and printhead. This will cause the ink-system to malfunction. The ink reservoir should be refilled within 15 minutes to prevent print failure.

Setting the Ink alarm:

1. Touch the *Settings* icon.
2. Touch the *Printer* menu.
3. Set the *Low ink prints* to the desired value.

Setting the Low ink output level:

1. Touch the *Settings* icon.
2. Touch the *Signal* menu.
3. Set the *Low ink level* to the desired value (high or low).

As soon as the amount of Low ink prints has been reached the Ink out alarm will be set.

Setting the Ink out output level:

1. Touch the *Settings* icon.
2. Touch the *Signal* menu.
3. Set the *Ink out level* to the desired value (high or low).

7.6 User settings

Fill out this table with the values found by setting the printer parameters. Use the table, as a reference, to set the printer parameters when the memory is reset to the default values.

Alternatively create a Report file, see section 9.2.5 and store it in a place where it can be found when needed e.g. the main label folder on the label design PC.

Keep the values nearby, when calling the helpdesk of your local distributor.

COMMISSION

Printer firmware version:					
QiC control version:					
WinCE version:					
WinOS version:					
Parameter	Default value	User setting	Parameter	Default value	User setting
Print speed, A	10 m/min		Low ink prints, A	500	
Print speed, B	10 m/min		Low ink prints, B	500	
Encoder	no		Print missed act, A	error	
Print input	High		Print missed act, B	error	
Print delay, A	0 [mm]		Spit enable, A	disable	
Print delay, B	0 [mm]		Spit enable, B	disable	
Print quantity, A	0		Spit delay, A	0	
Print quantity, B	0		Spit delay, B	0	
Debounce	10 [ms]		Spit interval, A	2000	
Product direction, A	Right to left		Spit interval, B	2000	
Product direction, B	Right to left		Spit lines, A	1	
Orientation, A	normal		Spit lines, B	1	
Orientation, B	normal		Printer ID	0	
Stretch, A	1		IP address	10.0.1.2xx	
Stretch, B	1		Subnet	255.255.255.0	
Encoder time-out	error		Gateway	0.0.0.0	
Start paused	yes		System language	English	
Busy output	High		Date language	English	
Alarm output	High				

Fig. 7.16 Printer parameters, default and user values

Fill out this table and keep nearby, when calling the helpdesk of your local distributor.

Manufacturer host machine, type	
X-series printer model	
Control unit, serial number	A
Coding unit A, serial number	B
Coding unit B, serial number	B
Production plant	
Production line	
Type of substrate (product) / Ribbon type	/
Production / print rate	Cycles / min
Ambient temperature (min, max)	°C (min) / °C (max)

Fig. 7.17 Printer information

8 OPERATION

This part describes the functions and procedures for operating the printer.



Beware:

If there are two coding units connected to one controller, some parameters should be set for each individual coding unit, see section 8.7.

8.1 Powering up

1. Check whether the printer is damaged by visual inspection.
2. Check whether all of the relevant cables are connected.
3. Switch on the control unit.



Note:

When the system parameter *Start paused* is set to *No*, the printer will start printing as soon as the print engine is powered up and a print request is received. The print engine is active before the Main menu is shown. Refer to subsection 8.6.1.

4. Wait until the Main menu is shown.

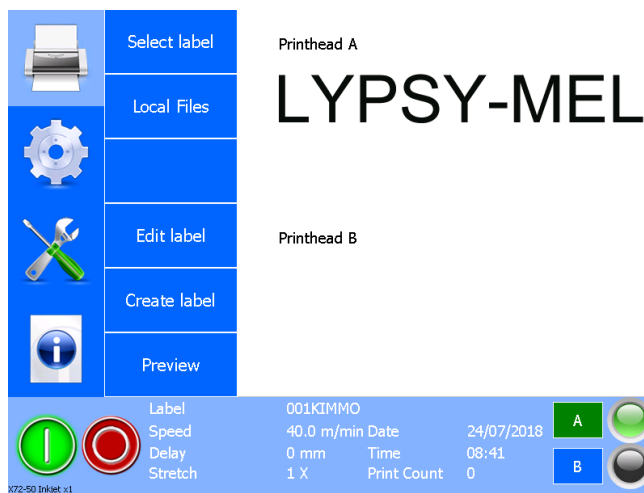

Fig. 8.1 Main menu

5. Check whether the printer is ready to print, the LED indicator on screen should show a green light.
6. Access the desired menu function by pressing the appropriate function icon or button.

8.2 Operational

8.2.1 Start printing

1. Check whether the desired label is selected. If not, touch the *Print* icon, touch the *Select label* Button and select a label. Refer to subsection 8.4.1 for more information about how to select a label.

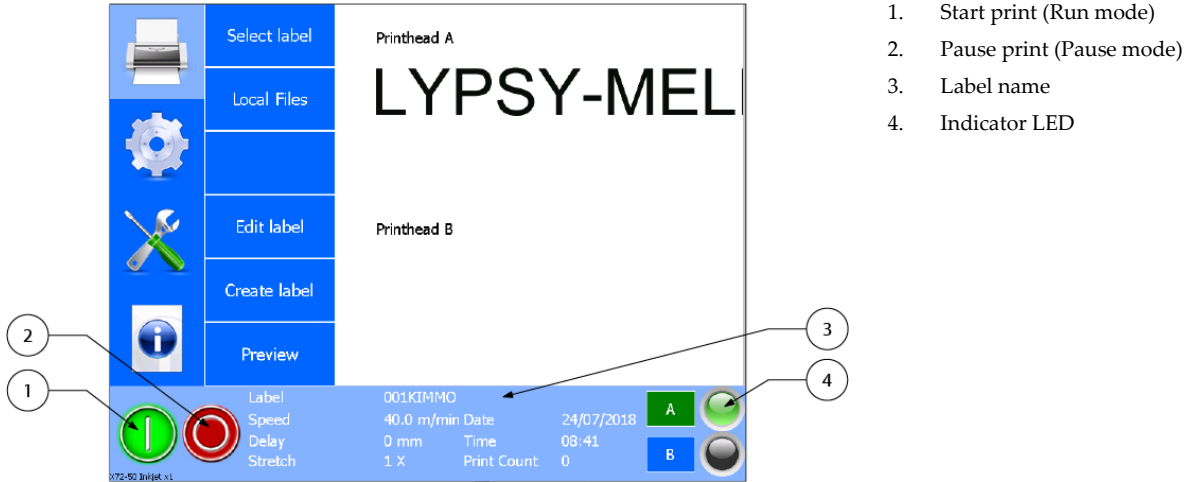

Fig. 8.2 Main menu – Status bar

2. Check whether the *Start print* button is activated, if not touch the *Start print* button to set the printer in the run mode.
3. Apply a print request signal to the printer and the printer will make a print.
4. To pause the printer, touch the *Pause print* button.



Note:

If a print request is received during the pause mode, a popup will appear on screen, showing warning 44: the printer is paused.

8.3 Operator data input

Labels can contain operator input fields which are defined during the label design process. These operator input fields should be filled out by the operator at the start of the print session.

Refer to subsection 3.5.3 for the available keyboard options.

8.3.1 Text item input menu

The operator input text can be entered using the keyboard. The user prompt text can be set during label design.

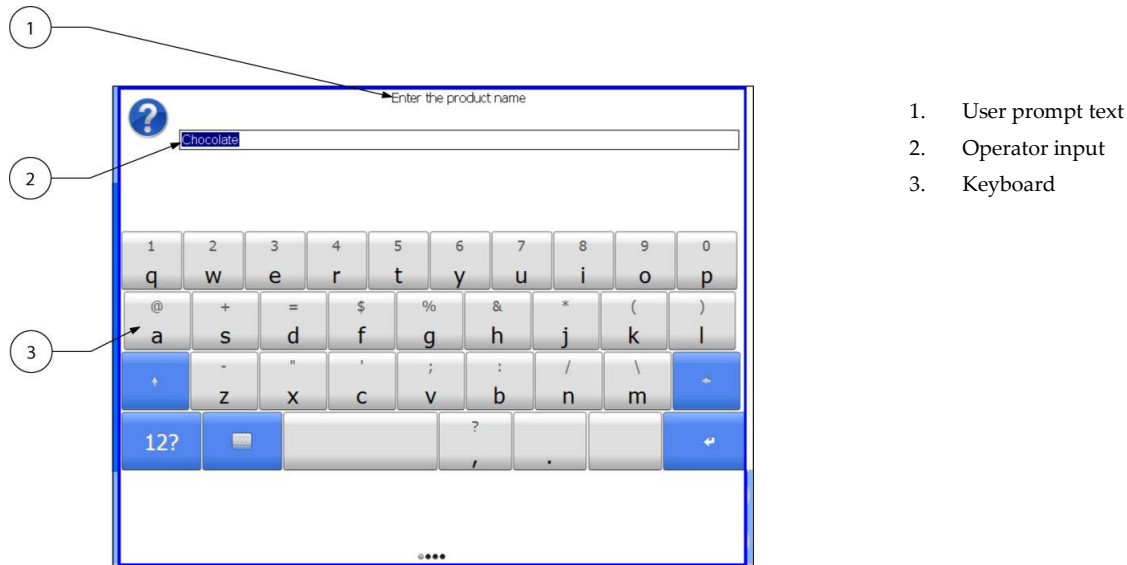

Fig. 8.3 Text item input menu

The use of a user prompt is especially useful if a label has more than one text item that requires changing the contents.

The Operator input shows the text which was used during the previous print run with the selected label or the initial string defined in the label design program. In addition, the length of this string is defined in the label design program. The string, which can contain any mix of characters, can be edited by the operator. One can mark the character(s) which need to be edited and touch the required character(s) that need(s) to replace the old character(s). Alternatively a cursor is indicating the location at which a new character will be inserted.

Use the keys of the keyboard to enter alphanumeric characters. Refer to subsection 3.5.3 for selecting the alternative keyboards.

To edit a string:

1. Touch the Operator input text to select the character(s) that need(s) to be changed.
2. Enter the desired new character(s). The desired character(s) is (are) inserted at the cursor position.
3. Repeat the previous instructions until all the characters have been edited or entered.
4. To delete characters, select the characters that need to be deleted and touch *Backspace*. Alternatively, place the cursor behind the characters that need to be deleted and touch *Backspace* to remove character by character.
5. Touch *Enter* to confirm the Operator input.

8.3.2 Date advance input menu

The offset (advance) of a date code can also be entered using an operator input. The User prompt text can be set during the label design.

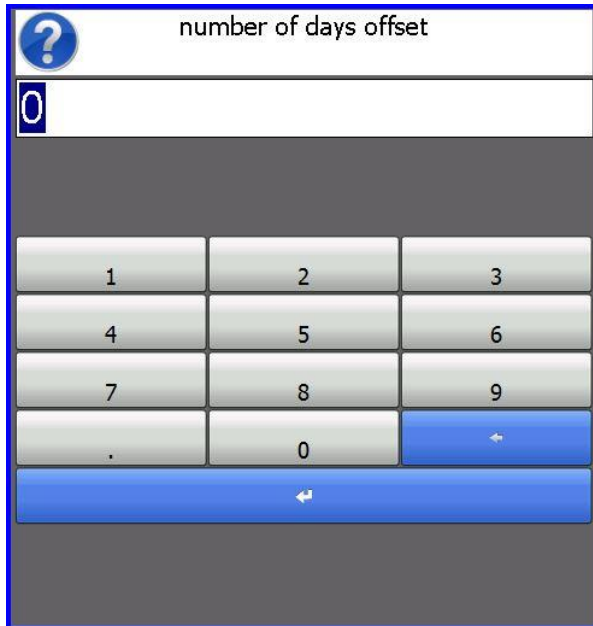

Fig. 8.4 Date advance input menu

The date field, which can be edited by the operator, only accepts valid inputs.

To edit the value of the Date advance item:

To enter a complete new value:

1. Enter the desired new offset.
2. Touch *Enter* to confirm the Operator input.

To change only a few numbers:

1. Touch the Input text to select the digit(s) that need(s) to be changed.
2. Enter the desired new digit(s). The desired digit(s) is (are) inserted at the cursor position.
3. Repeat the previous instructions until all the digit(s) have been edited or entered.
4. To delete digits, select the digits that need to be deleted and touch *Backspace*. Alternatively, place the cursor behind the digit that need to be deleted and touch *Backspace* to remove the text digit by digit.
5. Touch *Enter* to confirm the Operator input.

8.3.3 Number start value input menu

The number displayed on screen is the last value entered on the system by the operator. The very first time the label is selected, it will show the start value entered in the label design software.



Note:

Operator input for number items is on available when using a label design program.

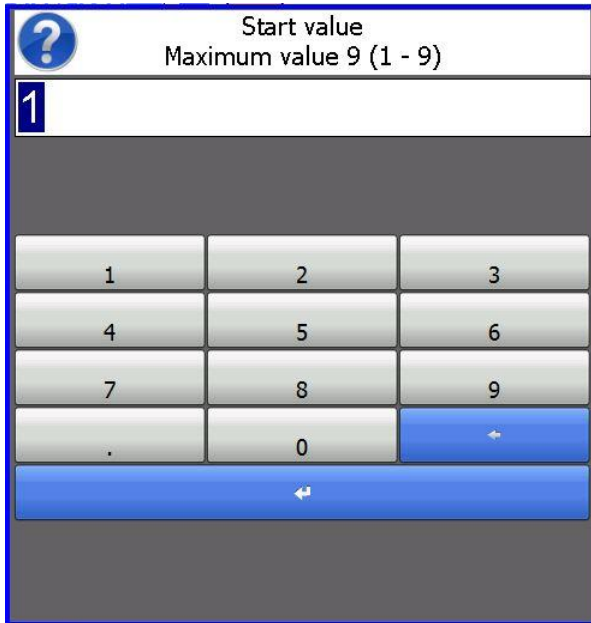

Fig. 8.5 Number start value input menu

The number field shows the last entered value used at a previous print run with this label or the initial value defined by the label design program.

The number field, which can be edited by the operator, only accepts valid numbers as defined by the label design program.

To enter a complete new value:

1. Enter the desired new digit(s).
2. Touch *Enter* to confirm the Operator input.

To change only a few characters:

1. Touch the Input text to select the digit(s) that needs to be changed.
2. Enter the desired new digit(s). The desired digit(s) is (are) inserted at the cursor position.
3. Repeat the previous instructions until all the digits have been edited or entered.
4. To delete (a) digit(s), select the digit(s) that need to be deleted and touch *Backspace*. Alternatively, place the cursor behind the digit(s) that need to be deleted and touch *Backspace* to remove the text digit by digit.
5. Touch *Enter* to confirm the Operator input.

8.4 Label management

8.4.1 Selecting a label for printing

To select a label from the label memory:

1. Touch the *Print* icon.
2. Touch the *Select label* button. The contents of the label memory is displayed and a further two buttons will appear, *Select* and *Cancel*.

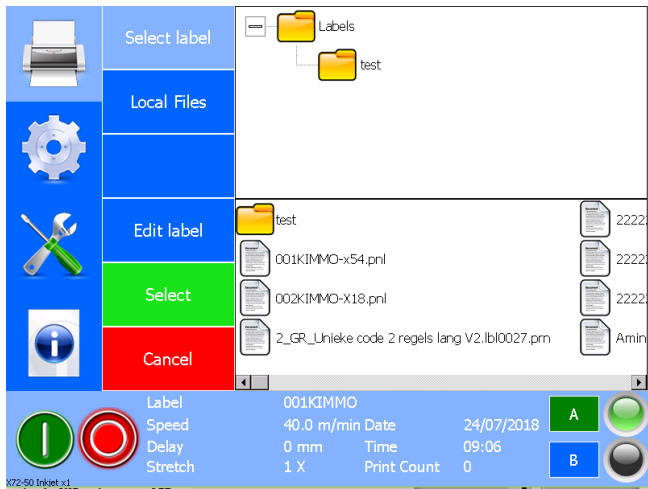

Fig. 8.6 Select label menu

3. Touch a folder and alternatively its sub-folder in the upper window to make the label files appear in the lower window.
4. Touch the label that needs to be printed in the lower window.
5. Touch the *Select* button.
6. The operator input screen will appear if the label selected requires the input of data, see section 8.3.
7. Enter the required data and touch *Enter*, the system will return to the Main screen. The name of the selected label will be shown in the status bar, behind *Label*.
8. Touching the *Preview* button will show a preview of the label that will be printed, see also section 8.4.8

8.4.2 List labels (Local files)

Use this option to list the labels on the system. There is nothing else one can do here at the moment.

8.4.3 Add labels

To transfer labels to the controller first insert a USB thumbdrive containing one or more labels and/or label directories and wait for around 3 seconds (for USB thumbdrive with a LED: wait until the LED flashes).



CAUTION:

Do not use an extension cable for connecting the USB thumbdrive to the controller, but place the USB thumbdrive directly in the controller. Using an extension cable can cause EMC interference.

1. Touch the *Print* icon.
2. Touch on the *Local Files* button, then on *Labels* and then on *Add labels*. The contents of the USB thumbdrive is displayed. Folders in the top window, labels in the bottom window. The blue buttons in the top right corner can be used to select all labels (button with * on it) or deselect all labels (empty button). Two extra buttons will appear in the second column, *Copy* and *Cancel*. Press cancel to abort the complete copy procedure and return to the main menu.

OPERATION

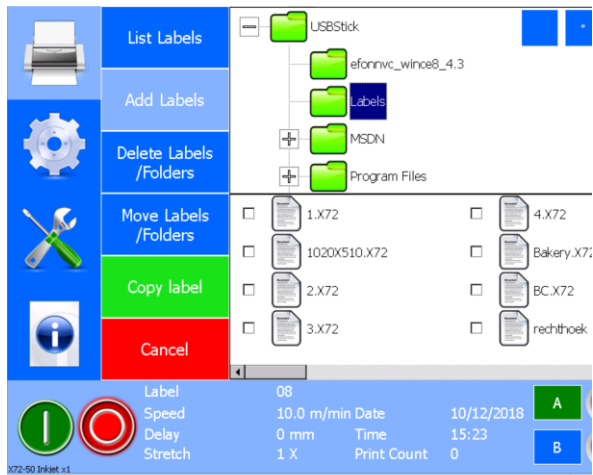

Fig. 8.7 Copy label menu, USB thumbdrive



Note:

The folders that are stored on the USB thumbdrive are shown in green, while the folders that are stored in the label memory are shown in yellow.

3. Touch a folder or one of its sub-folders in the upper window to make the label files appear in the lower window.
4. Touch the sub-folder or file that needs to be copied in the lower window.
5. Touch the *Copy* button.
6. The screen will now show the label memory.

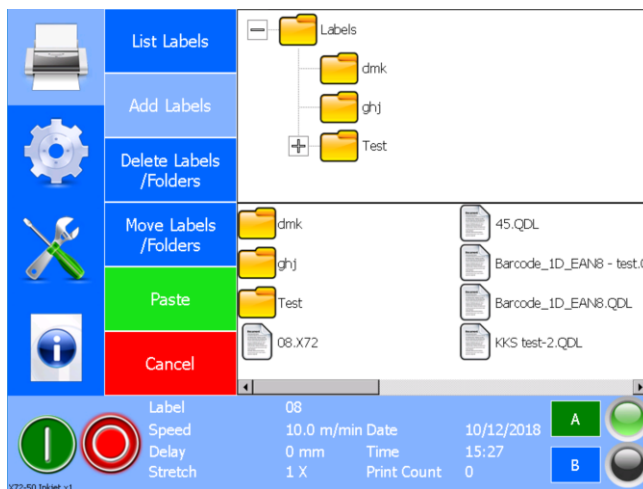

Fig. 8.8 Copy label menu, label memory

7. Touch the label folder to which the labels need to be copied to (The printer initially has one folder called Labels).
8. Select the *Paste* button. The selected USB thumbdrive labels will now be copied to the controller.
9. If a label name already exists in the label memory the Overwrite label message will appear on screen.



Fig. 8.9 Overwriting label message

10. Touch *Yes* and the label will be overwritten.
11. Touch *No* and the Paste operation will be cancelled.
12. When there is not enough memory available for the labels to be copied, an Insufficient memory message appears on screen. Copying 'new' labels is only possible when some 'old' labels are deleted or the memory is cleared. Refer to the next subsections 8.4.5.
13. The system will return to the main *Print* menu, the copy procedure is now finished.

8.4.4 Moving a label

There is a Move function available to make it possible to rearrange the label files and directories.

1. Touch the *Print* icon.
2. Touch the *Local Files* button, then touch *Labels* and then *Move labels*. Two additional buttons appear, *Move* and *Cancel*..

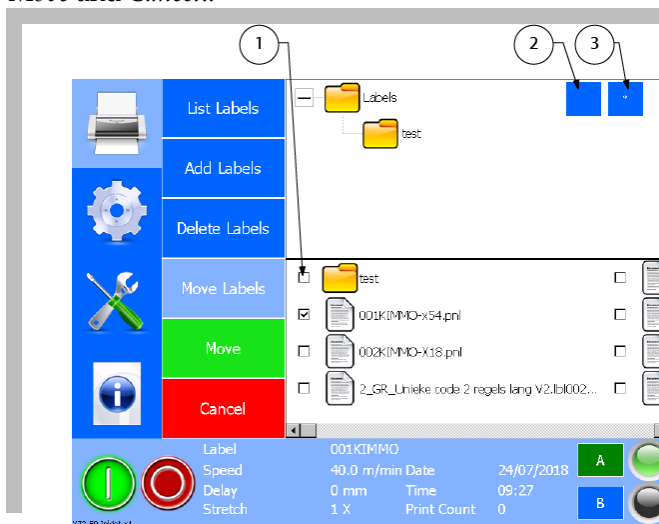

Fig. 8.10 Move label menu

3. In the lower screen section, select the label(s) or the folder to be moved. To select a label(s), touch the box to the left of the label. There is a so-called 'check mark' in it when the label is selected. With the blue buttons at the top right of the screen (2 and 3) all labels can be deselected / selected at once.
4. Touch *Move*, the following screen will appear.

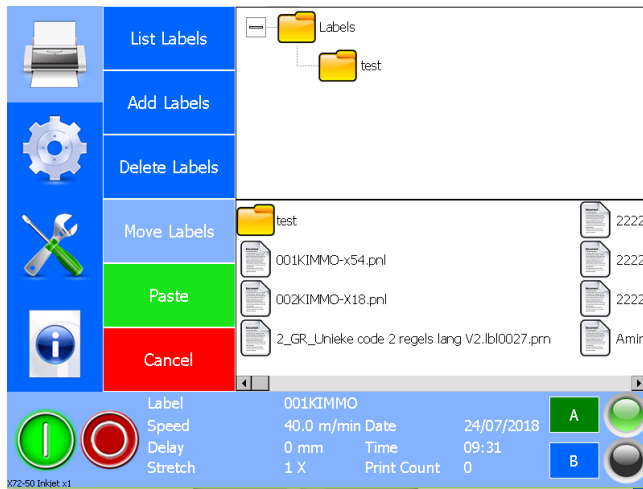

Fig. 8.11 Paste label menu

5. Touch the folder to which the label(s) or folder(s) need(s) to be moved to in the upper window.
6. Touch the *Paste* button.
7. When moving has completed, the system will return to the main *Print* menu.

8.4.5 Deleting a label

There is a Delete function available to make it possible to remove labels and/or folders.

1. Touch the *Print* icon.
2. Touch the *Local files* button, then touch *Labels* and then touch *Remove labels*. Two additional buttons appear, *Delete* and *Cancel*.

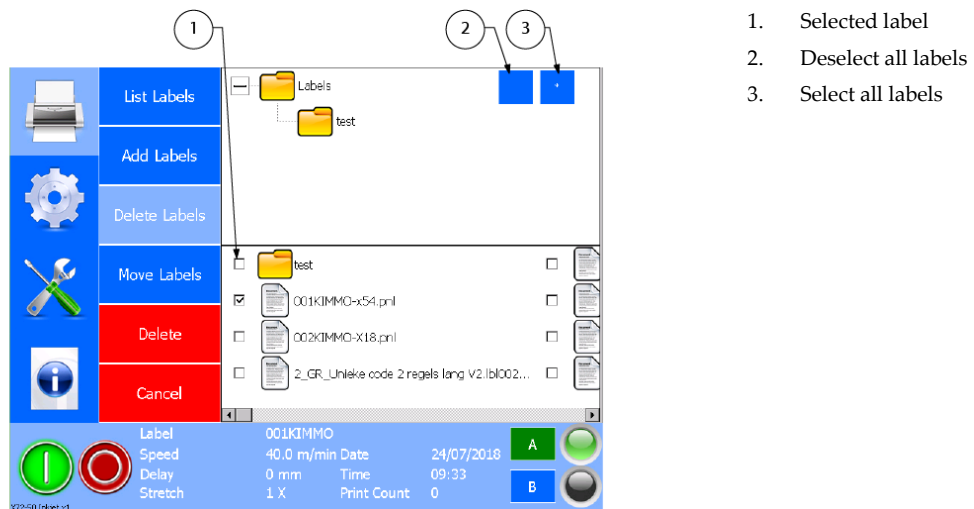

Fig. 8.12 Delete label menu

3. Select the label(s) or folder(s) that need(s) to be deleted by pressing the selection box in front of the name in the lower window. A checkmark indicates the file / folder is selected. With the blue buttons in the top right, one can select (3) or deselect (2) all labels / folders
4. Touch *Delete*, the following screen will appear.



Fig. 8.13 Delete label message

5. If the label or folder really needs to be deleted, confirm this by pressing *Yes*.
6. If the label or folder does not need to be deleted, touch *No* to cancel the operation.

8.4.6 Editing a label

There is an Edit label function available to make it possible to edit a label that is stored in the printers label memory.



Note:

Only labels designed on the control unit, see 8.4.7, can be edited.

1. Touch the *Print* icon.
2. Touch the *Edit label* button.
3. Select the label that needs to be edited in the lower window.

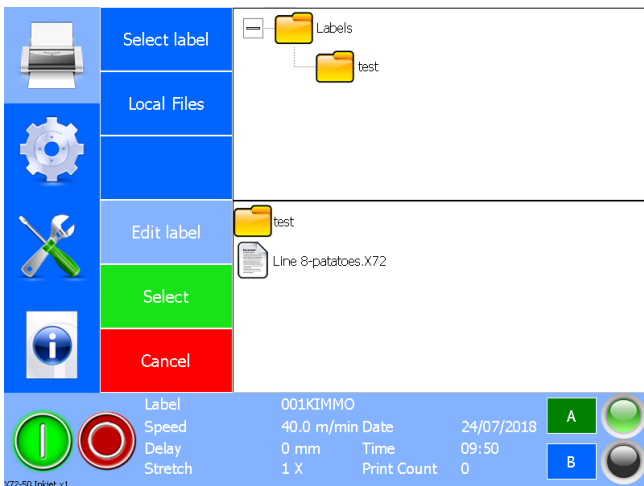



Fig. 8.14 Select a label for editing

4. Touch the *Select* Button and the Create label menu will open showing the selected label.





Fig. 8.15 Edit a label

5. Edit the label:

- a. Touch the item that needs to be edited, a blue square will appear around the item;
- b. By touching the item and by dragging it around the position of the item can be changed;
- c. By touching the edit icon  the content of the item can be changed.

**Note:**

See chapter 8.4.7 for a full description of the label item features.

6. For interim saving the label; touch the Save icon .
7. Touch the Close icon  to exit the label editor.
8. If no changes have been made to the label since saving it the last time, the Label editor is closed and one returns to the Edit label menu. If the label was changed before the last save, the system will ask whether to exit without changing the label. Touch *No* to return to the Label editor. Touch *Yes* to exit without saving the changes in the label.

See chapter 8.4.7 for a full description of the label item features.

8.4.7 Creating a label

There is a Create label function available to make it possible to create a label on the control unit.

1. Touch the *Print* icon.
2. Touch the *Create label* button, the Create label screen will appear on screen.

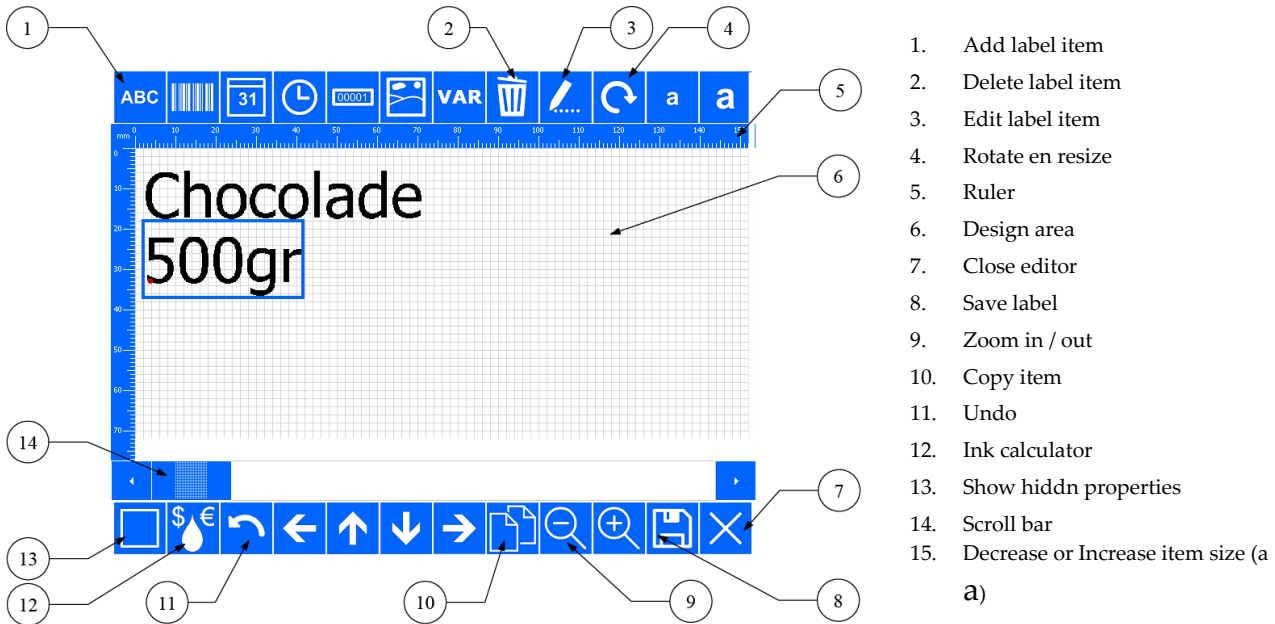









Fig. 8.16 Create label screen

1. Add label item
2. Delete label item
3. Edit label item
4. Rotate en resize
5. Ruler
6. Design area
7. Close editor
8. Save label
9. Zoom in / out
10. Copy item
11. Undo
12. Ink calculator
13. Show hiddn properties
14. Scroll bar
15. Decrease or Increase item size (a a)

3. To add a label item touch the corresponding Add label item icon:

- a.  Text :
 - Font: select the font type from the font list.
 - Text: enter the required text through the keyboard.
 - Variable text: Disabled => fixed text / Enabled => operator can change the text when the label will be selected for printing.
 - Add description: only activated when Variable text is enabled. Offers the option to give the operator a hint regarding the text he has to enter. Enter the required text through the keyboard.
- b.  Barcode:
 - Value: enter the required barcode value (text or numbers) through the keyboard.
 - Type: select the type of barcode from the barcode list.
 - Human readable: Disabled => no human readable character will be printed below the barcode. Enabled=> the value of the barcode will be printed below the barcode.
 - Module width: selects the width of the smallest bar of the barcode. Enter the required number through the keyboard
 - Barcode height: selects the height of the barcode. Enter the required number through the keyboard.
- c.  Date:
 - Font: select the font type from the font list.
 - Format: select the required date format from the option list.
 - Separator: select the required separator form the option list.
 - Offset: enter the required offset through the keyboard and select the offset unit from the option list.
 - Prompt: Disabled => fixed Offset / Enabled => operator can change the offset value when the label will be selected for printing. When Enabled one can also enter an operator hint which refers to the offset value he has to enter. Enter the required text through the keyboard.

- d.  Time:
 - Font: select the font type from the font list.
 - Format: select the required time format from the option list.
- e.  Counter:
 - Font: select the font type from the font list.
 - Start: enter the required start value through the keyboard.
 - Increment: enter the required step size through the keyboard.
 - Count before update: enter the required amount of prints that have to be made with the same number through the keyboard.
 - Rollover: enter the number at which the counter should stop and should restart counting starting at the entered start value. Enter the value through the keyboard.
- f.  Graphics:
 - Select a graphic from the graphics list.
- g.  Variables:
 - This option is used to add, modify or delete variables which can be used inside a label. Variables can be used to form a composite text or barcode. For example, a barcode can be built from a combination of text, date and counter. See appendix I for further information about creating and using variables

4. To delete a label item:
 - a. Select the item that needs to be deleted by touching it..
 - b. Touch the Delete icon.
5. To edit a label item:
 - a. Select the item that needs to be edited by touching it.
 - b. Touch the Edit icon.
 - c. The entry screen associated with the label item will appear on screen.
 - d. Edit the required values and press Ok.
6. To rotate the label item:
 - a. Select the item that needs to be rotated by touching it.
 - b. Touch the Rotate icon.
7. To adjust the item size (barcodes only human readable):
 - a. Select the item that needs to be resized by touching it.
 - b. Touch the Decrease or Increase icon (a or a).
8. To undo the latest changes:
 - a. Touch the Undo icon
9. To duplicate a label item:
 - a. Select the label item to be duplicated
 - b. Touch the Duplicate button to duplicate the item.
10. To zoom in or out:
 - a. Touch the Zoom out or Zoom in icon.
11. To save the label:
 - a. Touch the Save icon.
 - b. Enter the label name.
 - c. Touch Ok to save the label.

- d. The system will return to the Create label screen.
- 12. To calculate the ink consumption per print:
 - a. Touch the Ink calculator icon.

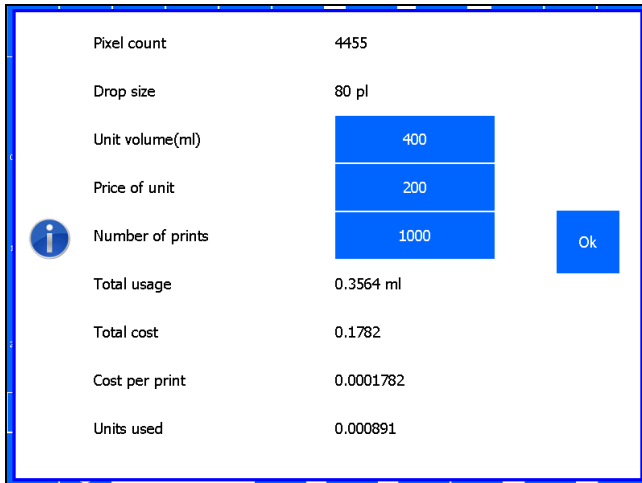

Fig. 8.17 Ink calculator screen

- b. The system will mention the Pixel count of the current label design and the drop size of a single ink droplet of the coding unit that is connected to the control unit.
- c. Enter the Unit volume (ml) – normally the volume of one set of ink of 400ml.
- d. Enter the Price per unit – normally the price of one set of ink.
- e. Enter the number of prints to be made.
- f. After entering each value the system will automatically calculate:
 - Total usage: the total ink consumption for printing the set amount of prints.
 - Total cost: the total cost for printing the set amount of prints.
 - Cost per print: the cost for printing a single print.
 - Units used: the amount of ink units needed for printing the set amount of prints – normally the amount of ink sets of 400ml needed.
 - Touch Ok to return to the Create label screen.

PS: The calculation of the ink consumption and therefore of the price (per print and total) is an approximation of reality. The number of pixels used to print a label is exact, however, the droplet size is an approximation based on the data from the manufacturer of the printhead used. The calculation does not take into account the tolerances in droplet size. Also the "stretch" function is not included in the calculation. By default, this is set to 1. If it is set to a different value, then multiply the result of the calculation by the Stretch value.

With the X72 it is also possible to change the offset voltage. If it is made larger than "0", the droplet size will increase. If it is made smaller than "0", the droplet size will become smaller.

- 13. To move a label item, select it by tapping it. Then press and hold it and drag the item to the desired location. One can also use the arrow keys for more precision. It is also possible to select a group of items to be moved. Place the finger in an empty area and drag the purple selection box over the items to be moved. The item selection box will appear purple when it is selected. After selecting the items, press and release on an item which is the reference point for moving. Next, place the finger on the item which selection box is blue now and drag the group to the new location.
- 14. To view extra label information:
 - a. Press icon *Show hidden properties*. All the items in the label will show a rectangle around it and some extra information in regards to the item. At the left bottom of the design area, 5 alignment functions and *goto next label item* button also appear and will be explained below:
 - b. The grey rectangle indicates the area that could be updated if the item is an autocode (time, date, number or a variable). If items overlap, it's possible that the contents are partially overwritten by other items. The grey rectangles give a good indication of how far the items can actually overlap each other.

- c. In red text, one can see the items font type and font size.
- d. In blue text, one can see the so-called *Field number*. This number can be used by external software to update the contents of text, barcode and variable items.
- e. To the right hand side in the design area, a list of variables is shown, together with the field numbers (blue) and variable name (red). (If variables are used that is!)
- f. The alignment buttons are self-explanatory, from left to right; left align, right align, top align, bottom align and centre align. To select the items that require alignment, first select the item(s) to align. To do this, touch the screen in an unused area and while keeping contact with the touch screen, move your finger over the items requiring alignment. The grey rectangle will change colour to purple if an item is selected. Next, select the item to align to, the item box will turn blue. Once the items have been selected, press the desired align icon.
- g. *Goto next label item* can be pressed to select the next item in the label. Using this button will prevent accidental movement of the item that requires editing.

15. To exit the label editor:

- a. Touch the Close editor icon.
- b. If the latest label changes have already been saved the system will return to the Print menu.
- c. If the latest label changes have not been saved the Save label screen will appear. Touch *No* to return to the Edit label screen and store the changes in the label, see step 11. Touch *Yes* to exit without saving the changes in the label.



Note:

If a label is too big to be shown on screen, one can scroll through the label by using the scroll bar (14).



Beware:

The label items placed outside of the label grid will be saved with the label, but will not be printed.

8.4.8 Showing a preview

There is a Preview function available that will show the currently printed label on screen.

1. Touch the *Print* icon.
2. Touch *Preview* and the first preview screen will show a 1:8 picture.

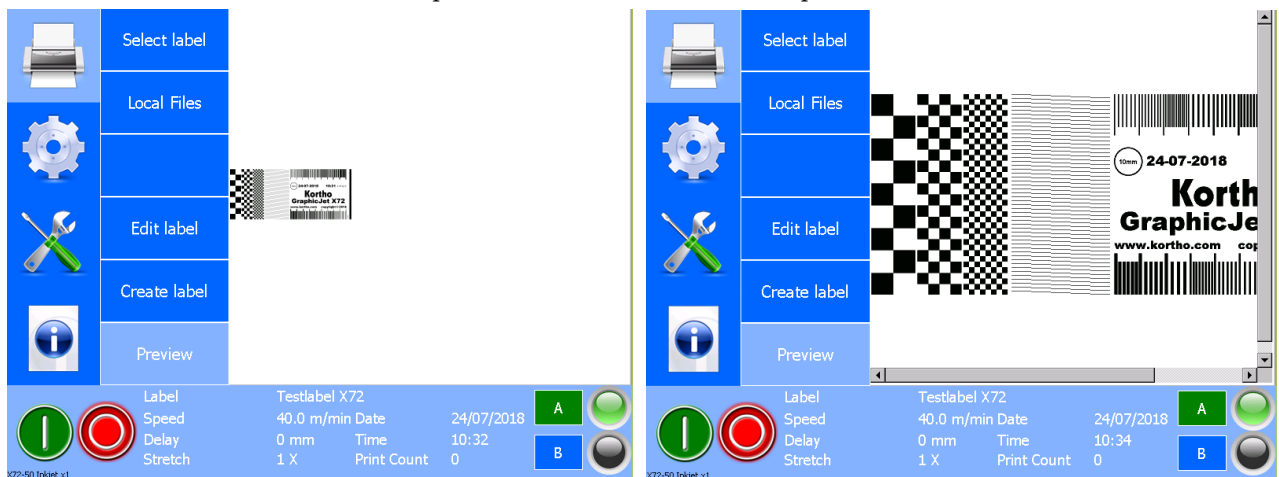

Fig. 8.18 Preview screen 1:8 and 1:1

3. Touch *Preview* again to show a 1:4 picture;
4. Touch *Preview* again to show a 1:2 picture.
5. Touch *Preview* again to show a 1:1 picture.
6. Touch *Preview* again to show the 1:8 picture again.

When the label is larger than the screen, one can use the scrollbar to drag the preview around.

8.5 Re-filling the ink reservoir

1. Pause the printing process.
2. Put on protection gloves and use safety goggles for personal protection.
3. Clean and remove any dust from the top of the ink reservoir.
4. Take an ink bottle and cut off the end, which is indicated with a ring, of the spout top (Fig. 8.19).



CAUTION:

Use ONLY Kortho GJ inks in 200 ml bottles [X18 / X18+ / X54 / X72] or 100ml bottles [X18si], see also the indicator on the reservoir.



Fig. 8.19 Cut ink bottle open

5. Open the ink reservoir by unscrewing the screw cap (Fig. 8.20) counter clockwise. Put the screw cap aside at a clean place.



Fig. 8.20 Ink reservoir opened.

6. Place, without spilling ink, the ink bottle upside-down into the ink reservoir fill opening (Fig. 8.21).
7. Squeeze the ink bottle gently until it is empty. The status LED of the coding unit, on the screen of the controller, will change from orange to green.



CAUTION:

Fill the ink reservoir with ONE 200ml ink bottle [X18 / X18+ / X54 / X72], maximum TWO 100ml ink bottles [X18si] ONLY, filling with more than one ink bottle will cause ink leakage or overflow.



Fig. 8.21 Ink reservoir with ink bottle placed.

8. Remove the empty ink bottle and avoid spilling ink. Clean the reservoir opening with a clean paper tissue.
9. Close the ink reservoir by screwing the screw cap back on. Hand tight is sufficient.

8.5.1 Purging the printhead

This procedure is meant to test the piezo elements of the printhead or to clear the nozzles when the print shows minor flaws.

1. Touch the Pause mode button to abort the print process.
2. Put on protection gloves and use safety goggles for personal protection.
3. Touch the *Service* icon.
4. Touch the *Test* menu.
5. Hold paper tissues in front of the printhead to collect ink.
6. Touch the *Test* button behind *Purge ink* to start the purge process. Keep the button activated to continue purging.

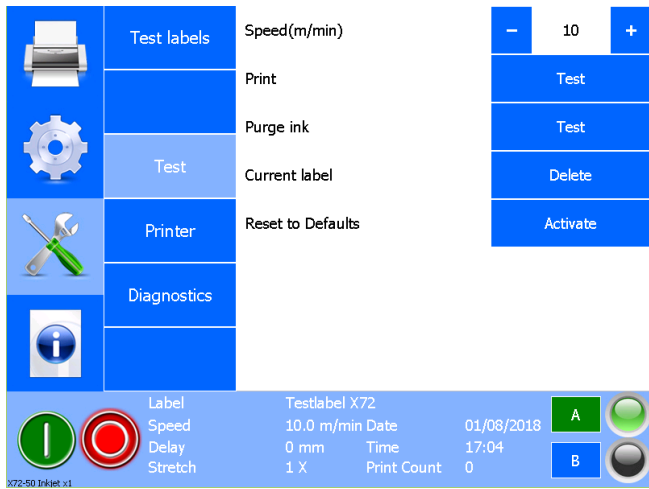

Fig. 8.22 Purging

7. Make a sample print.
8. Repeat the purge procedure if the print is improved but still poor. If purging is not sufficient, refer then the prime procedure in subsection 8.5.2.

8.5.2 Priming the printhead

When the printhead or ink tubes contain air bubbles or the printhead nozzles are clogged, the ink system needs to be primed.

1. Touch the Pause mode button to abort the print process.
2. Put on protection gloves and use safety goggles for personal protection.
3. Rotate, if necessary, the printhead housing to the horizontal position (Fig. 8.23).

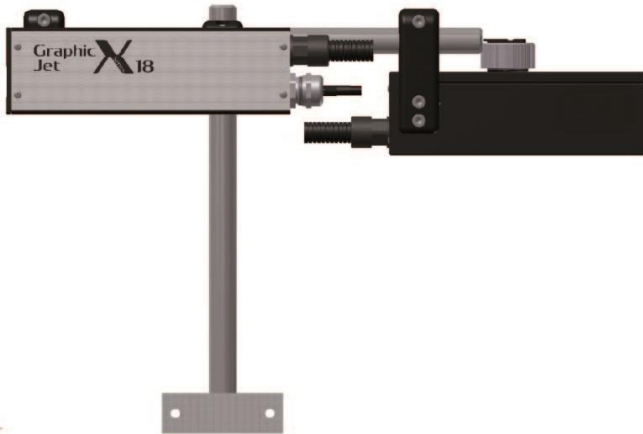
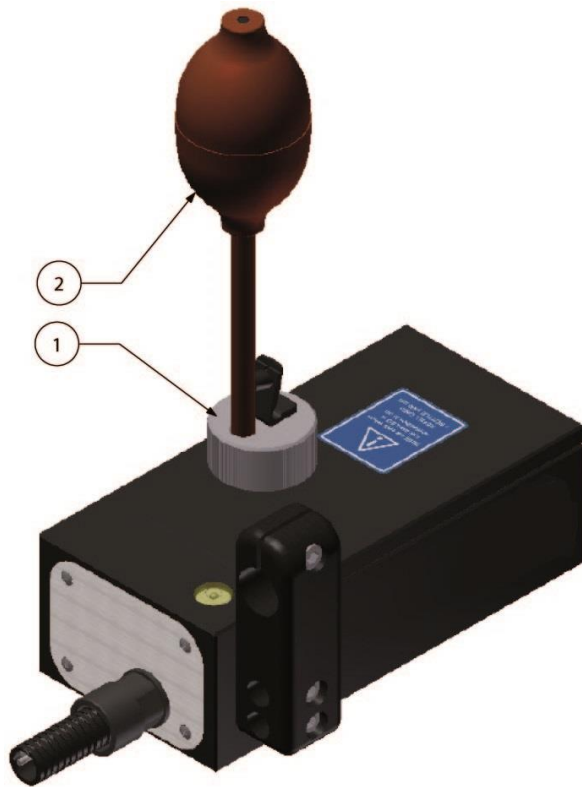

Fig. 8.23 Printhead housing at horizontal position

4. Fit the prime bulb to the opening of the vent knob (Fig. 8.24) of the ink reservoir.



1. Screw cap
2. Prime bulb

Fig. 8.24 Ink reservoir with prime bulb attached.

5. Hold clean paper tissues or a waste container in front of the printhead to collect ink.
6. Squeeze the prime bulb completely just one time to prime the printhead. Prime in bursts of about three to five seconds to remove any air bubbles out of the ink system.
7. Repeat priming until ink squirts from all the nozzles.
8. Remove the prime (gently, to avoid a pressure wave within the ink tubes) from the fitting of the ink reservoir to stop priming the printhead.
9. Let the ink run of the front plate and clean the frontplate carefully without touching the nozzleplate of the printhead. Use some solvent, *the type that is compatible with the ink – no other liquids*, if necessary.
10. Rotate the printhead housing back to the print position.
11. The printer is now ready to print.

8.6 Adjusting printer settings



Beware:

If there are two coding units connected to one controller, some parameters should be set for each individual coding unit, see section 8.7.

1. Touch the *Settings* icon. The following status screen is shown.

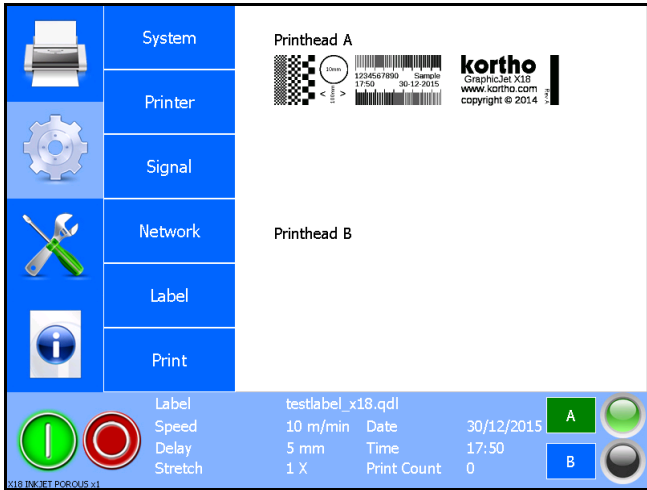

Fig. 8.25 Settings menu

8.6.1 System settings

1. To change the system settings touch the *System* button.

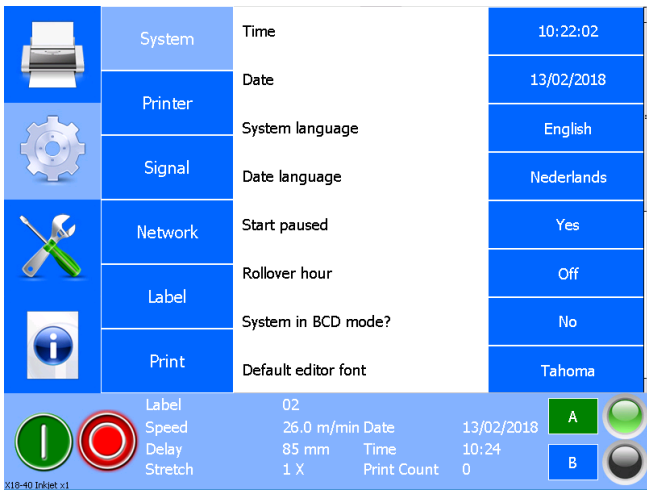

Fig. 8.26 System settings menu

Time

1. Touch the blue button that shows *Time*.

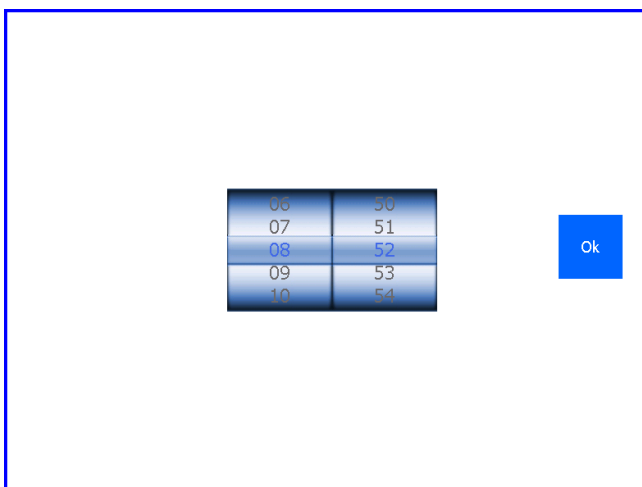

Fig. 8.27 Setting the time

2. Rotate the left hand part to set the hour and the right hand part to set the minutes.

3. Press Ok to save the time setting.

Date

1. Touch the blue button that shows *Date*.

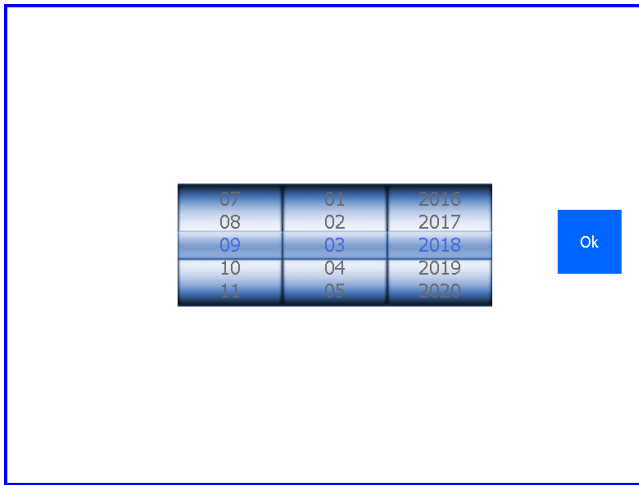

Fig. 8.28 Setting the date

2. Move the left part up or down to set the day, the middle part to set the month and the right part to set the year.
3. Press Ok to save the date setting.

System language

1. Touch the blue button that shows System language.

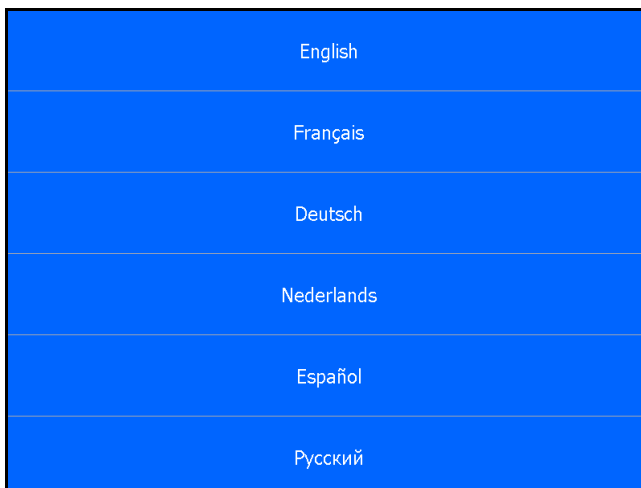

Fig. 8.29 System language selection menu

4. Touch a language button to select another language.



Note:

When there are more languages than fit on screen, one can touch the screen and drag up and downwards to select the required language.

Date language

The language set as Date language is used to print the Months and Day of the week (e.g. when set to English: Monday, Mon, January, Jan. When set to Dutch: Maandag, Maa, Januari, Jan).

1. Touch the *Date language* button.

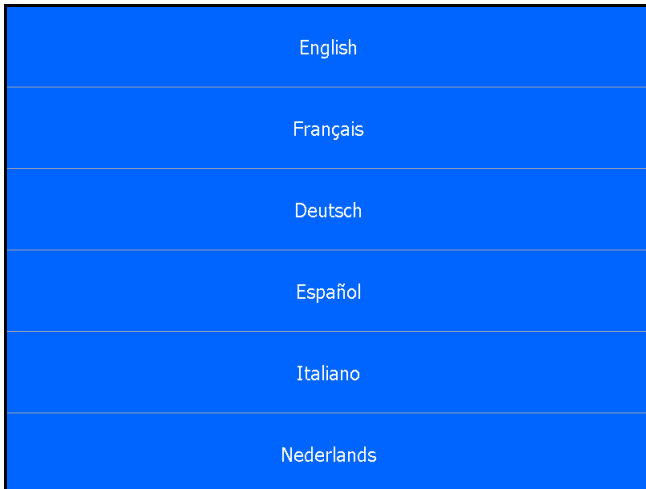

Fig. 8.30 Date Language selection menu

2. Touch a language button to select another language.

Start paused

1. Touch the blue button that shows *Start paused* to change the setting from *No* to *Yes* or from *Yes* to *No*.

When *Yes* is selected the printer will start in pause mode. While in pause mode the printer will ignore applied print request signals. In order to start the print process the operator should touch the start print button.

When *No* is selected the printer will start in run mode. The printer will immediately make a print when the print processor is ready to start the print process and a print request signal is applied.

Rollover hour

1. Touch the blue button that shows *Rollover hour* to change the hour at which the printed date needs to turn over to the next day.

The default setting is Off, which means the date will turn over to the next day at 00:00. If e.g. the date needs to change at 03:00, the Rollover hour needs to be set to +3.

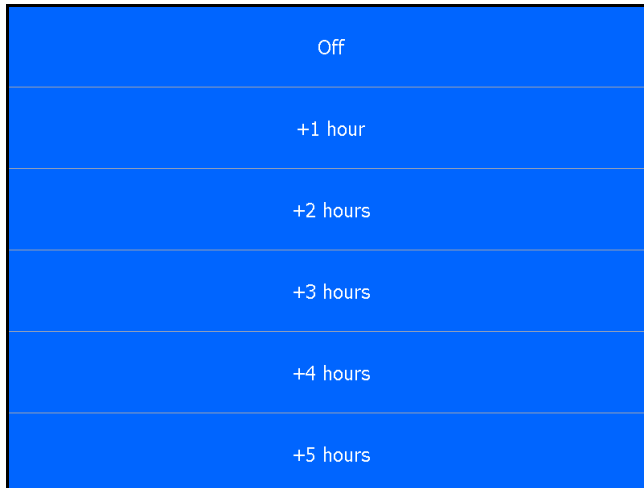

Fig. 8.31 Rollover hour selection menu

System in BCD mode?

BCD mode is a mode the controller can be put in, in order to be able to print labels which have been selected by a BCD code which has been applied to the controller BCD input and stored by activating the product detect input. This makes it possible to print a different label on each product if required. The labels have to be present in the controller. See appendix H for more detailed information regarding BCD-mode.

1. Touch the blue button *System in BCD mode* to change the setting from *No* to *Yes* or from *Yes* to *No*. The default setting is *No*. This means that BCD mode is NOT activated.

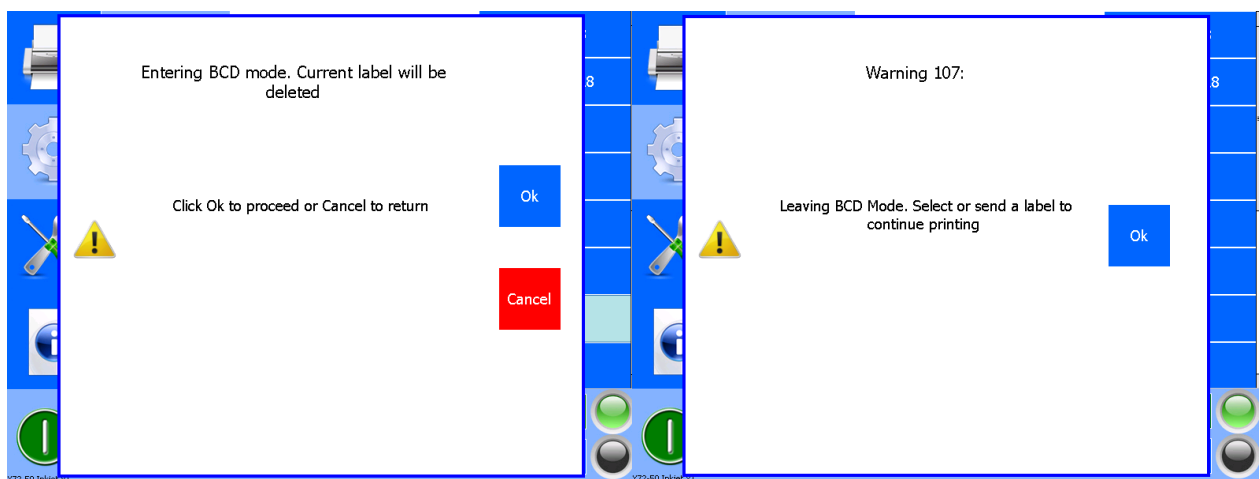

Fig. 8.32 Messages when activating / deactivating of the BCD mode

Default label editor font

1. Touch the blue button under Default font editor to change the default font setting for the label editor.

The default setting is Tahoma, which means that the default font for new label items, added to the label, is Tahoma.



Note:

When there are more fonts than fit on the screen, you can touch the screen, and drag up and down to select the desired font.

Send label to all heads?

1. Touch the blue button behind *Send label to all heads* to change the setting from *No* to *Yes* or from *Yes* to *No*.

The default setting is *No*, which means that the label is only sent to the selected printhead. When *Send label to all heads* is set to *Yes* then the label is sent to all connected printheads.

Keep warning on screen?

1. Touch the blue button behind *Keep warning on screen* to change the setting from *No* to *Yes* or from *Yes* to *No*.

The default setting is *No*, which means that warnings that appear on screen disappear after 5 seconds. When *Keep warning on screen* is set to *Yes* then the warning remains on the screen until OK is pressed.

First day of the week

1. Touch the blue button behind *First day of the week* to change the setting from *Sunday* to *Monday* or from *Monday* to *Sunday*.

The default setting is *Monday*, which means that the day numbering starts with 1 on Monday, 2 on Tuesday etc. When *First day of the week* is set to *Sunday*, the day numbering starts with 1 on Sunday, 2 on Monday etc.

Screen saver

1. Touch the blue button behind *Screen saver* to change the setting for the screen saver.

The default setting is *Off*, which means that screen saver is never activated. For example, if the screen saver has to be activated after 10 minutes not touching the screen, the screen saver must be set to 10 min.

The screen saver is deactivated by touching the screen.

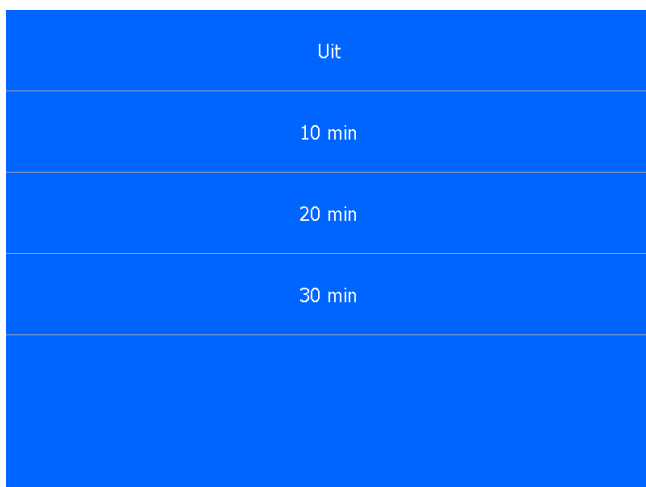

Fig. 8.33 Menu Schermbeveiliging

Julian offset

1. Touch the blue button behind *Julian offset* to change the Julian Offset.

The default setting is 0, which means that 0 days are added to the offset of all Julian date items used in a label. For example, if all Julian date items in a label have to be increased by 400 days, *Julian offset* must be set to 400. If an offset has already been added to a Julian date item, then Julian Offset is added to it.

Daylight saving

1. Touch the blue button behind *Daylight saving* to change the Daylight saving setting. The default setting is what it means that the printer will automatically adjust the time to summer or winter time if necessary.



Note:

When there are more menus than fit on the screen you can touch the screen, and drag up and down to select the desired menu.

8.6.2 Printer settings

To change the printer settings touch the *Printer* button.

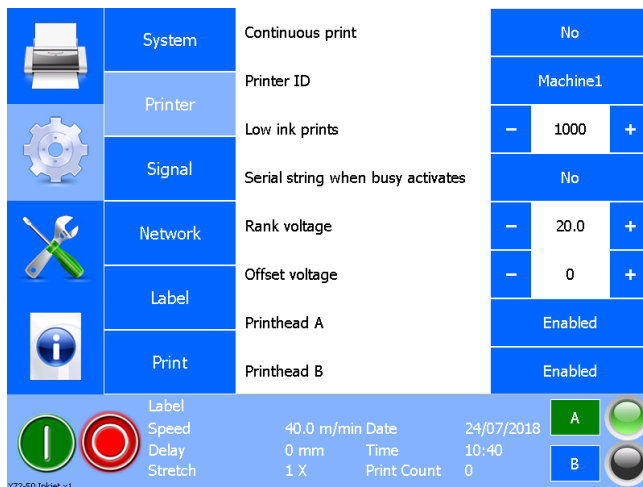

Fig. 8.34 System settings menu

Changing the printer settings

To change numeric settings:

1. Touch the + / - buttons, or
2. Touch the value shown to enter it from the numerical keyboard.

To change selectable settings:

1. Touch the button and the setting will change (toggle function), or
2. When touching the button a list of choices will appear from which the required setting can be selected.

Continuous print

This parameter could be set to *Yes* or *No*. When set to *No*, the printer will make a print every time a print signal is applied. When set to *Yes*, the printer will start printing in a continuous mode as soon as a print signal is applied and as long as the print signal is activated (high or low – depending on the Print input setting, see also subsections 7.4.3 and 8.6.3). The printer will stop printing when the print signal is deactivated. The distance between prints is set with the *Print delay* option in Settings -> Print.

Printer ID

This is a text or number that can be used to identify the printer. The printer ID can be used in the label and can in this way be printed on the substrate.

**Note:**

The Printer ID is also used by the KCC software to display a printer in the network on the screen. Use an appropriate name to identify the printer.

Low ink prints

The *Low ink prints* setting lets the printer print the set amount of prints when the ink level in the ink reservoir is low. At ink low condition, the printer will generate an ink low warning on screen. After the set amount of prints has been reached the printer stops printing, will put an ink out error on screen and the Ink out output will be activated. See also subsection 7.5.2.

**CAUTION:**

If the Low ink prints is set to a relatively high value, there is an apparent risk that air is able to enter the ink tubing and printhead. This will cause the system to produce bad or no prints. The ink reservoir should be refilled as soon as possible to avoid this situation.

Serial string after busy

This function makes it possible to send data via the serial port connection (X05) when a print cycle is started. The data toggles each print between character "A" and "B". The settings of the serial port are: baud rate 19200, data bits 8, stop bit 1, parity none, data transport control none.

This function is used in some applications to link back when a label is printed. For example, the application that runs on a PC receives this data ("A" or "B" and can subsequently perform certain actions to eg send a new label for the next print.

Product direction [X54] [X72]

This option is only visible when a X54 or X72 coding unit is connected to the controller.

Because the nozzles of the print head are not positioned as one vertical line, it is important for the print quality that the product direction is set correctly. The product direction depends on the direction of movement of the product, either from left to right or from right to left, as seen from the back of the coding unit in the direction of the production line.

Rank voltage [X72]

The rank voltage is the voltage for the printhead, at which the printhead is functioning optimally at 25 ° C. The rank voltage can be different for every X72 printhead and is written on a sticker which is applied on the X72 printhead.

**Caution:**

A wrong setting of the rank voltage will affect the proper functioning of the printer. The rank voltage should only be set when

1. a X72 system is installed for the first time,
2. a new X72 coding unit is connected to the control unit
3. a X72 printhead is replaced by a new X72 printhead.

Offset Voltage [X72]

The offset voltage is a possible correction on the automatic control voltage for the print head. The default setting is 0 volt.

**Caution:**

The offset voltage is a possible correction on the automatic control voltage for the print head. A positive offset results in a slightly larger drop (ie slightly blacker print) and a slightly larger print distance, but the placement accuracy of the droplets may decrease slightly, which may make the print slightly less sharp. The default setting is 0 volts.

Printhead A

With this function printhead A can be *enabled* or *disabled*. If the printhead is turned off, the printhead will not print.

Printhead B

With this function printhead B can be enabled or disabled. If the printhead is turned off, the printhead will not print.

Security

With this function the protection of the controller can be activated. If the protection is activated, an image will be displayed on the screen after a configurable time, (see Settings -> System -> Screensaver) or immediately after pressing the blue *Lock* button in the upper left corner of the main screen. If you want to use the controller you will have to fill in the set password when you touch the screen. Also see appendix J.

User password

This function allows you to set the user password to be entered if security is activated and the screen is locked. See appendix J to set the password.

Line ID

This is a text or number that can be used to identify a production line. The line ID can be used in the label and can thus be printed on the substrate.

Customer ID

This is a text or number that can be used to identify a customer of the product being coded. The customer ID can be used in the label and can thus be printed on the substrate.

**Note:**

When there are more menus than fit on the screen you can touch the screen, and drag up and down to select the desired menu.

8.6.3 Signal settings

To change the signal settings touch the *Signal* button.



CAUTION:

These settings will be set during installation; only a trained engineer should change them.

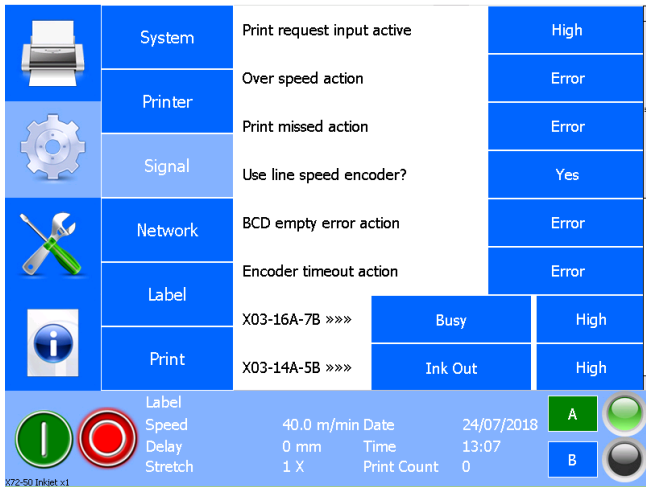

Fig. 8.35 Signal settings menu

Changing the signal settings

To change numeric settings:

1. Touch the + / - buttons, or
2. Touch the value shown to enter it from the numerical keyboard.

To change selectable settings:

1. Touch the button and the setting will change (toggle function), or
2. When touching the button a list of choices will appear from which the required setting can be selected.



Note:

When there are more menus than fit on the screen you can touch the screen and drag up and down to select the desired menu.

Print request input active

Select the rising edge (*High*) or falling edge (*Low*) of the signal on the print request input to make a print.

Printspeed too fast action

This message is activated if the print speed at which the printer should print is too high (only when using a tape speed meter). This message can be set to Error or Warning. If it is set to Error, the printing process will stop, an error message will appear on screen and the general alarm output will be activated. When it is set to Warning, the printing process continues and a warning appears on the screen.

Print missed action

This message is activated when the printer receives a print signal while the current print cycle is still in progress. This message can be set to Error or Warning. When this is set to Error, missing a print will stop the printing process, an error message will appear on the screen and the general alarm output will become

active. When it is set to *Warning*, the printing process continues when a missed print is detected, and a warning appears on the screen.

Use line speed encoder?

This parameter can be set to *No* or *Yes*. When set to *No* the printer will print a fixed speed. This specific speed can be set in the control unit, see subsection 8.6.6. When set to *Yes*, the printer will print at the speed measured by the encoder that is connected to the control unit.



Note:

If an encoder is used for measuring the print speed, the system will follow the measured speed while printing. If the measured speed becomes zero (the substrate stops in front of the coding unit) during the print process (trigger signal – print finished), the printer will stop printing. If the substrate starts moving again within 30 seconds the printer will finish the print. If the substrate stops for over 30 seconds an encoder timeout message comes up, but the print will be finished when the line starts moving again.

BCD empty error action

This signal is active when there are no more prints in the BCD list and a print request is received. This parameter can be set to *Error* or *warning*. When it is set to *error*, this will stop the printing process and the general alarm will be activated. When this is set to *Warning*, the printing process will continue when the BCD list is empty and a warning will appear on the screen. However, the print will no longer change and the same label will be printed on each following product.

Encoder timeout action

This signal is active when, when using an encoder, the substrate is stationary for more than 30 seconds during a print cycle. This parameter can be set to *Error* or *Warning*. When it is set to *Error*, the printing process will stop and the general alarm will be activated. When it is set to *Warning*, the printing process continues and a warning appears on the screen.

X03-16A-7B »»» (by default *Busy* output)

Output pin 16(A) and 7(B) on connector X03. The function of this output pair can be selected from *Unused*, *Busy*, *Ink out*, *Ink low* or *General error* when touching the first blue button. Using the second blue button next to it, set the required output level when the output is active. This signal can be set to be active *High* or active *Low*.

By default, this output pair is linked to the *Busy* signal.

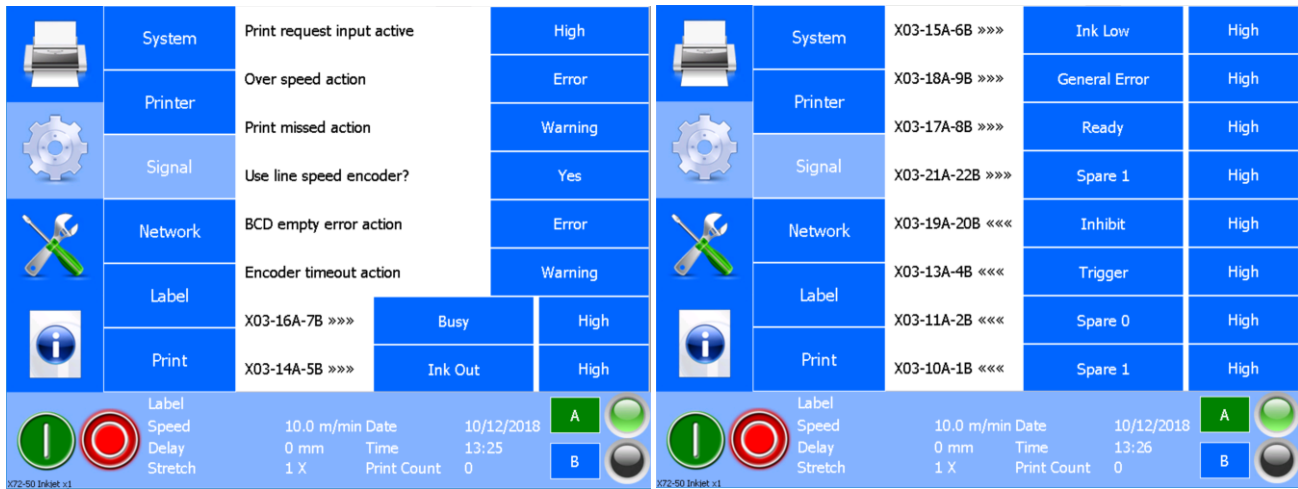

Fig. 8.36 Signal settings outputs and inputs

X03-14A-5B »»» (by default *Ink out* output)

Output pin 14(A) and 5(B) on connector X03. The function of this output pair can be selected from *Unused*, *Busy*, *Ink out*, *Ink low* or *General error* when touching the first blue button. Using the second blue button next to it, set the required output level when the output is active. This signal can be set to be active *High* or active *Low*.

By default, this output pair is linked to the *Ink out* signal.

X03-15A-6B »»» (by default *Low ink* output)

Output pin 15(A) and 6(B) on connector X03. The function of this output pair can be selected from *Unused*, *Busy*, *Ink out*, *Ink low* or *General error* when touching the first blue button. Using the second blue button next to it, set the required output level when the output is active. This signal can be set to be active *High* or active *Low*.

By default, this output pair is linked to the *Ink low* signal.

X03-18A-9B »»» (by default *General alarm* output)

Output pin 15(A) and 6(B) on connector X03. The function of this output pair can be selected from *Unused*, *Busy*, *Ink out*, *Ink low* or *General error* when touching the first blue button. Using the second blue button next to it, set the required output level when the output is active. This signal can be set to be active *High* or active *Low*.

By default, this output pair is linked to the *General alarm* signal.

X03-17A-8B »»» (by default *Ready* output)

Output pin 17(A) and 8(B) on connector X03. The function of this output pair can be selected from *Unused*, *Busy*, *Ink out*, *Ink low* or *General error* when touching the first blue button.

Using the second blue button next to it, set the required output level when the output is active. This signal can be set to be active *High* or active *Low*, but only active *High* will work, since active *Low* would be meaningless here.

By default, this output pair is linked to the *Ready* signal.

X03-21A-22B »»» (default *Spare 1* output)

Output pin 21A) and 22(B) on connector X03. The function of this output pair can be selected from *Unused*, *Busy*, *Ink out*, *Ink low* or *General error* when touching the first blue button. Using the second blue button next to it, set the required output level when the output is active. This signal can be set to be active *High* or active *Low*.

By default, this output pair is linked to the *Spare 1 output* signal. .

More information and schematics see appendix N

Functions of the outputs

- a. *Unused*: The output is not used.
- b. *Busy*: The busy signal tells the host machine that the printer is actually making a print. This signal can be used to make sure the substrate will never stop in front of the coding unit as long as the printer is actually printing.
- c. *Ink out*: The output signal tells the host machine that a low ink situation has occurred and the set amount of Low ink prints have been made. I.e. that an ink refill is required to continue. An Ink out error is shown on screen and the Ink out and alarm outputs are activated.
- d. *Ink low*: The output signal tells the host machine that a low ink situation has occurred and that an ink refill is required. A Low ink warning is displayed on screen and the low ink output is activated. The system will continue printing for the set amount of *Low ink* prints..
- e. *General error*: The output signal tells the host machine that an error has occurred which requires user attention. An error is shown on screen, the system stops the printing process and the General alarm output is activated.
- f. *Ready*: This output (Ready) will be active if the following conditions are met:
 - The system needs to be switched on,
 - The system is in Running mode,
 - The general alarm output is inactiveThis output can be used to check whether the system is indeed switched on and ready to make a print.
- g. *Spare 1*: Not used.

X03-19A-20B ««« (default *Inhibit* input)

Input pin 19A) and 20(B) on connector X03. The function of this input pair can be selected from *Unused*, *Inhibit*, *Trigger*, *Spare 0* or *Spare 1* when touching the first blue button. Using the second blue button next to it, set the required input level on which the input is active. This signal can be set to be active *High* or active *Low*.

By default, this input is linked to the *Inhibit* signal.

X03-13A-4B ««« (default *Trigger* input)

Input pin 13A) and 4(B) on connector X03. The function of this input pair can be selected from *Unused*, *Inhibit*, *Trigger*, *Spare 0* or *Spare 1* when touching the first blue button. Using the second blue button next to it, set the required input level on which the input is active. This signal can be set to be active *High* or active *Low*.

By default, this input is linked to the *Trigger* signal

X03-11A-2B ««« (Default Spare 0 input)

Input pin 11A) and 2(B) on connector X03. The function of this input pair can be selected from *Unused*, *Inhibit*, *Trigger*, *Spare 0* or *Spare 1* when touching the first blue button. Using the second blue button next to it, set the required input level on which the input is active. This signal can be set to be active *High* or active *Low*.

By default, this input is linked to the *Spare 0* signal

X03-10A-1B ««« (default Spare 1 input)

Input pin 10A) and 1(B) on connector X03. The function of this input pair can be selected from *Unused*, *Inhibit*, *Trigger*, *Spare 0* or *Spare 1* when touching the first blue button. Using the second blue button next to it, set the required input level on which the input is active. This signal can be set to be active *High* or active *Low*.

By default, this input is linked to the *Spare 1* signal.

More information and schematics see appendix N.

Functions of the inputs

- a. *Unused*: input is not used
- b. *Inhibit*: When the inhibit input is activated, the system will not print. When this input is activated during the print process, the print will be finished.
- c. *Trigger*: The trigger input can be used to update the counter in a label or to reset the counter to the start value.
- d. *Spare 0*: not used
- e. *Spare 1*: not used

8.6.4 Network settings

These settings make sure the system can be reached over the internal network and that communication between e.g. PC (label design) and printer can take place.

To make sure the settings will match the network settings, always ask the network administrator for help while integrating the printer into the company network.

To change the network settings of the printer touch the *Network* button.

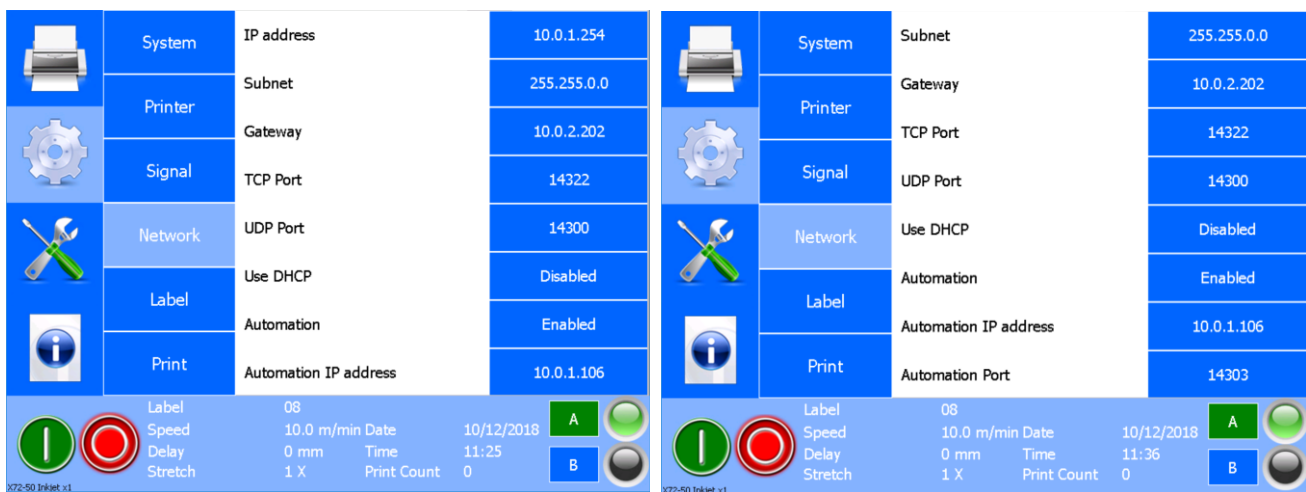

Fig. 8.37 Network settings menu

IP Address, Subnet and Gateway

1. Touch the corresponding blue button and the following screen will appear.

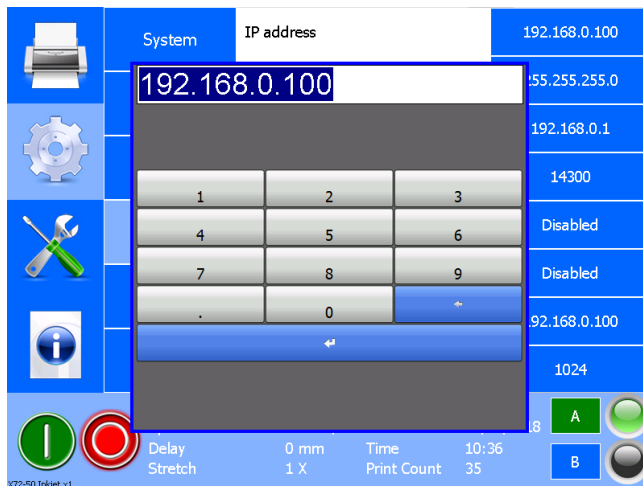

Fig. 8.38 Network settings, IP address

2. Enter the desired value (do not forget to enter the decimal points).
3. Confirm using *Enter*.

The new settings will be active within 15 seconds.

UDP Port

This setting determines the UDP port on which the system listens to the "broadcasts" which Kortho Control Center sends to determine which printers are connected to the network. In Kortho Control Center, the same UDP port must be selected so that the printers can be found.

1. Touch the blue button at TCP Port and the following screen appears:

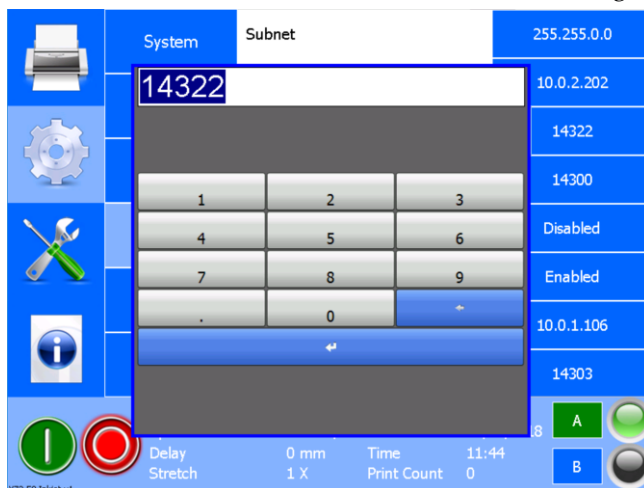

Fig. 8.39 Network settings, UDP Port

2. Enter the desired port number which needs to be within the range of 1024 – 49151.
3. Confirm using *Enter*.

The new settings are active after rebooting the system. (switch OFF and 10 seconds later, ON again)

Use DHCP

Select *Disabled* if using a fixed IP address for the printer or *Enabled* if the IP address for the printer is to be automatically assigned by the DHCP server in the network.

Automation

Select *Enabled* if PRINT_COMPLETE is to be sent to the IP address and Port number specified in the Automation IP address and Automation Port menus at the end of each print. Select *Disabled* if nothing needs to be sent. worden.

Automation IP address

1. Touch the blue button behind Automation IP address and the following screen appears.

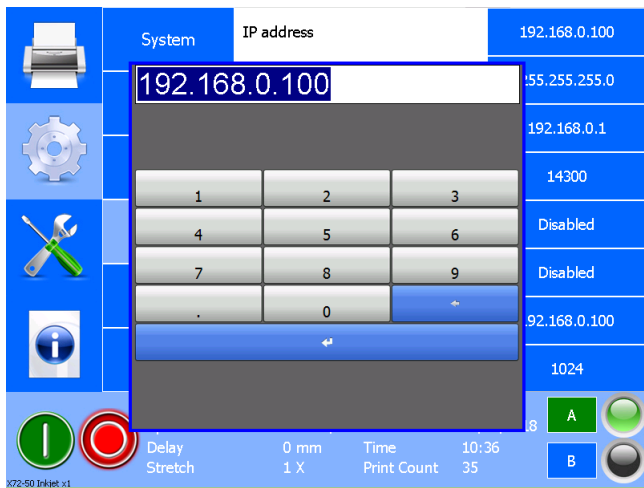

Fig. 8.40 Network settings, Automation IP address

2. Enter the desired value (do not forget to enter the decimal points).
3. Confirm using *Enter*.

Automation Port

1. Touch the blue button behind Automation Port and the following screen appears.

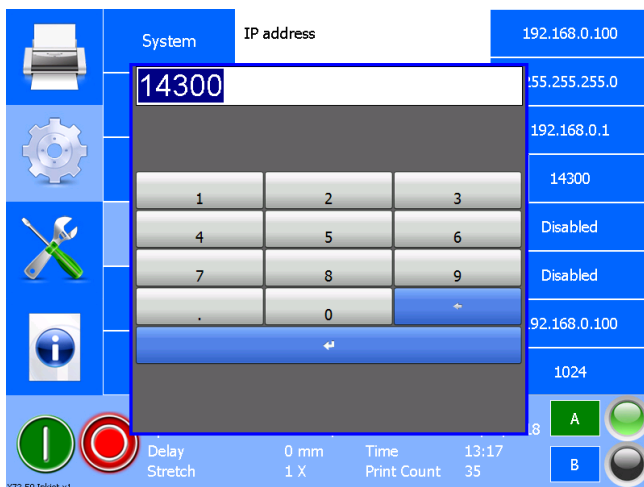

Fig. 8.41 Network settings, Automation Port

2. Enter the desired value.
3. Confirm using *Enter*.

8.6.5 Label settings

To change the label settings of the printer touch the *Label* button.

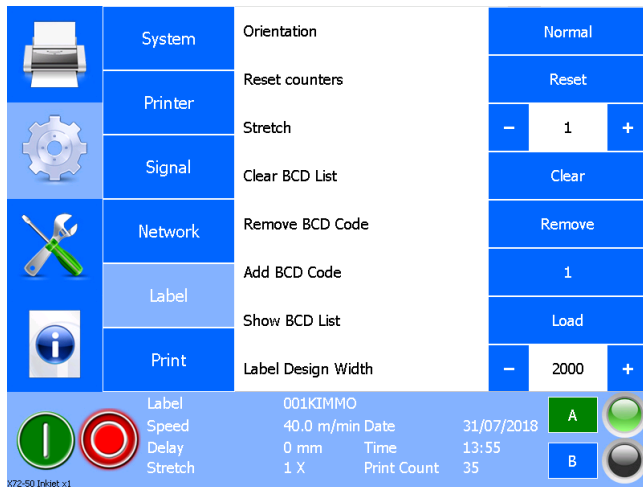

Fig. 8.42 Label settings menu

Orientation

The orientation of the label to be printed can be changed in the software of the printer.

1. Touch the *Orientation* button.

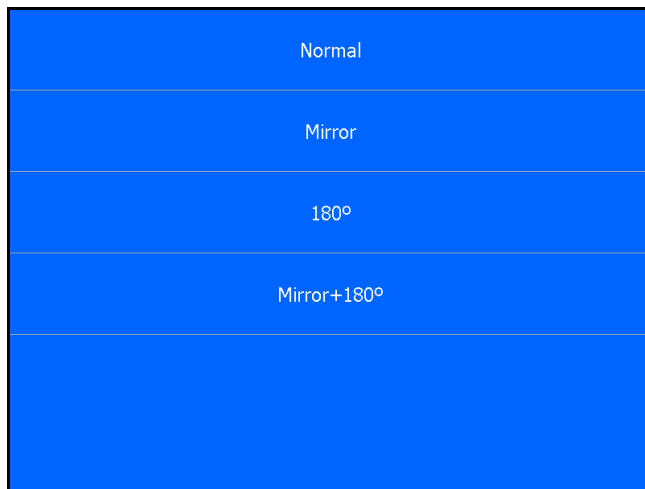
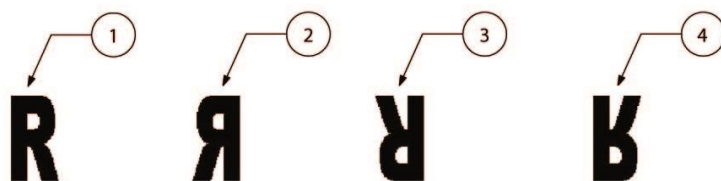

Fig. 8.43 Orientation setting selection

2. Select the required orientation.

Mirror flips the printed label along the width of the print head. *180°* rotates the label 180 degrees around the centre of the print head. *Mirror / 180°* combines the other two rotations.



1. Normal
2. Mirror
3. 180°
4. Mirror + 180°

Fig. 8.44 Orientation setting

Reset counters

The system counters, which can be used in the label, can be reset to their start value (default value defined in the label).

Stretch

The label can be stretched. The value set determines the amount of times each label pixel will be printed. E.g. if the stretch is set to 3 each pixel column will be printed three times. Consequently the length of the print will also be 3 times longer as the original label. The default value of this setting is 1.

Clear BCD list

The BCD Codes (selected labels), which are in the BCD list for printing, are deleted. One label is still loaded. The printer will still print it when a print request is received. If a consequent print request is received, the system will display Error 103, BCD list is empty, on the screen and the general error output will be activated. In order to be able to print again, a BCD code must be supplied and accepted by activating the Product Detect input.

Remove BCD Code

The first BCD code received will be removed from the BCD list. The function can be used until the BCD list is empty.

Add BCD Code

A BCD code can be added manually. The BCD code is added tot he end of the BCD list.

1. Press the button behind *Add BCD Code*.

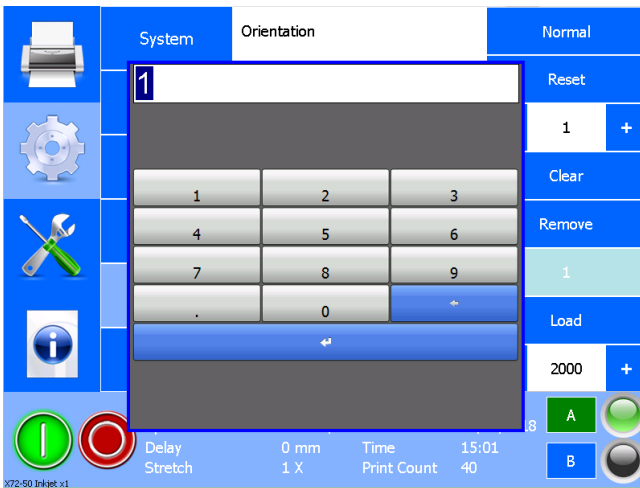
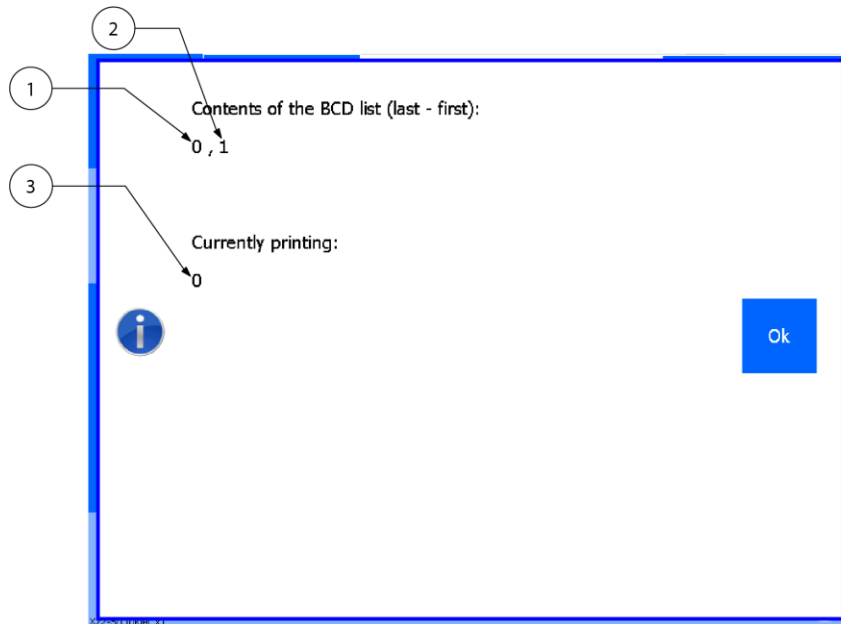

Fig. 8.45 Label Settings; Add BCD Code

2. Enter the BCD Code that needs to be entered at the end of the list.
3. Confirm using *Enter*.

Show BCD list

The BCD list will be shown.



1. BCD Code that was added to the BCD list first
2. Last added BCD Code
3. BCD Code that is currently printed

Fig. 8.46 Label settings; Load BCD list

Label Design Width

The *label design width* is the width of the label design area. The maximum design width for the X18 is 1500 millimeters, for the X54 and X72 it is 2000 millimeters..

To change the values of the label design width:

1. Press on one of the + / - buttons, or
2. Press the shown value to enter a new value on the numeric keyboard.
3. Confirm using *Enter*.

8.6.6 Print settings

To change the print settings of the printer touch the *Print* button.

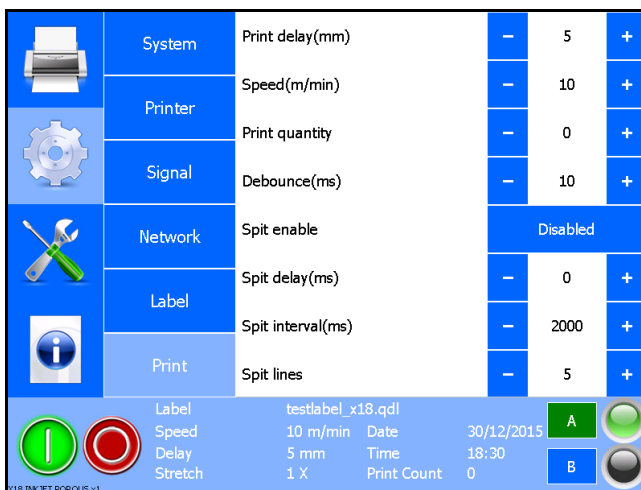

Fig. 8.47 Print settings menu

Changing the print settings

To change numeric settings:

4. Touch the + / - buttons, or
5. Touch the value shown to enter it from the numerical keyboard.

To change selectable settings:

1. Touch the button and the setting will change (toggle function), or
2. When touching the button a list with choices will appear from which the required setting can be selected.

Print delay

This value sets the *Delay*. Delay is the distance, set in mm, which the system will wait after receiving a print request before making the actual print. As the substrate is moving in front of the printhead, this setting can be used to position the print on the substrate.

Speed

This value sets the speed at which the printhead will print the labels when using the internal encoder, see subsection 8.6.3.

Print quantity

This value sets the number of labels to print. When the set value has been reached, the printer will stop the printing process and the General alarm output will be activated to indicate that the batch is complete. When set to zero the current label will print indefinitely.

Debounce

The debounce time is the time a print request signal needs to be active to be regarded as a valid print request. A shorter signal is considered to be noise and will not result in a print. The unit is in milliseconds.

Spit Enable

The spit function can be set to prevent the ink from clogging the nozzles and/or drying on/into the print head, see chapter 7.5. To use the spit function this function needs to be enabled.

Spit delay

The spit delay represents the time in milliseconds that the system will wait after a label has been printed, before starting to spit. The spit delay can be set to a value between 0 and 20.000 milliseconds. When zero is selected, the first pixel-column will be spit directly after the printed image. See also chapter 7.5.1.

Spit interval

The spit interval is the time between two spit actions, so the printhead will 'spit' a pixel-column of 128 dots of ink every 'x' (x= set value) milliseconds. The range of the spit interval can be set between 2.000 and 20.000 milliseconds. The spit interval is switched off when set to zero. See also chapter 7.5.1.

Spit lines

The amount of pixel columns that will be spitted every set interval. The amount of lines can be set between 1 and 5. See also chapter 7.5.1.

8.7 Specific settings for the TsC20-Duo

When two coding units are connected to one controller TsC20-Duo, the following settings should be made for each individual coding unit.

Printer settings

- Low ink prints
- Product direction [X54 / X72]
- Rank voltage [X72]
- Offset voltage [X72]

Signaal instellingen

- Print missed action

Label settings

- Orientation
- Stretch

Print settings

- Print delay
- Speed
- Print quantity
- Spit enable
- Spit delay
- Spit interval
- Spit lines

All other parameters are global parameters. Whether coding unit A or B is selected does not matter, once they are changed they will have effect on both coding units at the same time.

9 DIAGNOSTICS / TROUBLESHOOTING

For fault finding and problem solving a wide range of information screens and diagnostics functions are available in the system.

9.1 Service

Touch the *Service* icon located at the left side of the screen. The following status screen is shown.

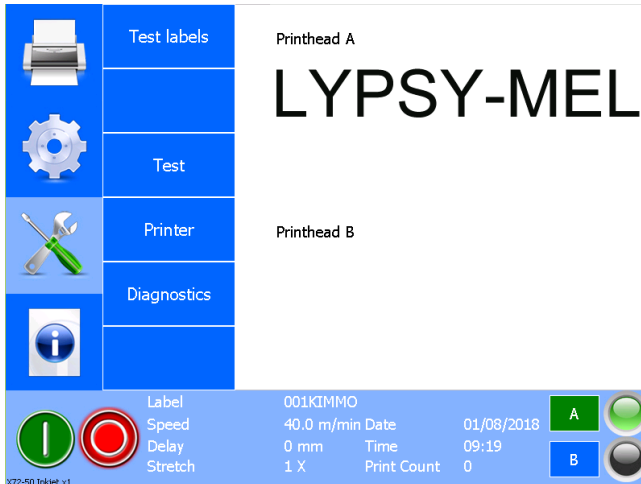

Fig. 9.1 Service menu



Beware:

Many of the features in this section only work when the printer is paused. Pause the printer by pressing the *Pause* icon. When paused the *Pause* icon is brightly lit red.

9.1.1 Test labels

For diagnostic reasons and for setting up the printer a test label is factory programmed. This label cannot be deleted from the system. To select the test label:

1. Touch the *TestLabels* button.

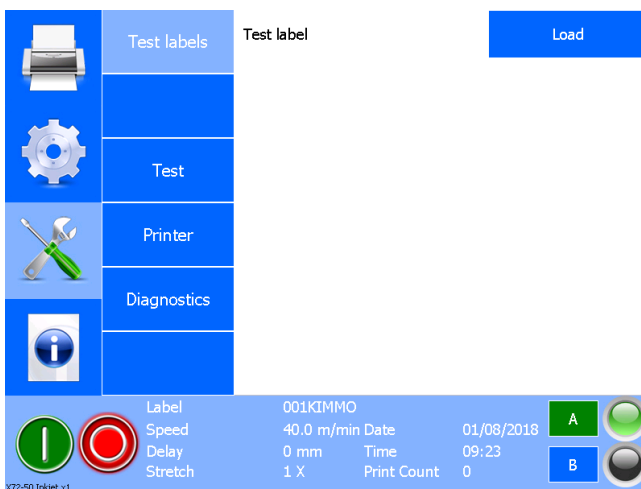

Fig. 9.2 Test label menu

2. Touch the *Load* button to load the test label. This label contains items like text, date, number and barcode.
3. The Test label loaded message will be displayed on screen.

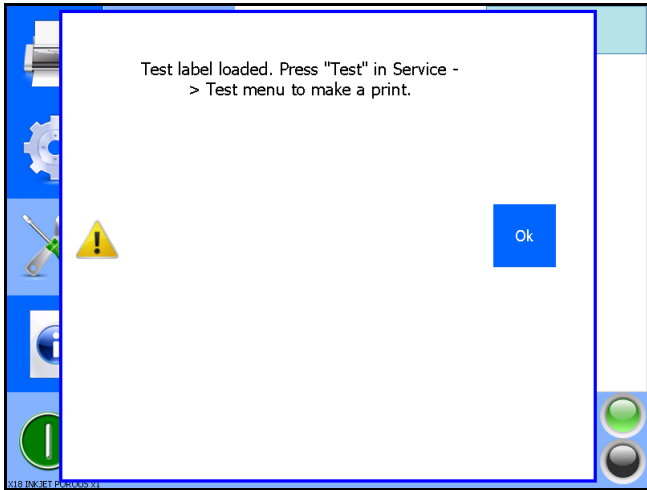

Fig. 9.3 Test label loaded

4. A sample print can be made by using the Diagnostics Test function (see section 9.1.3).



Beware:

The Test label will remain selected until a new label is selected. Make sure another label is selected when starting up the production, otherwise the Test label will be printed during production.

9.1.2 Fonts

Touch *Local files* and then the *Fonts* button located at the left side of the screen. The following status screen is shown.

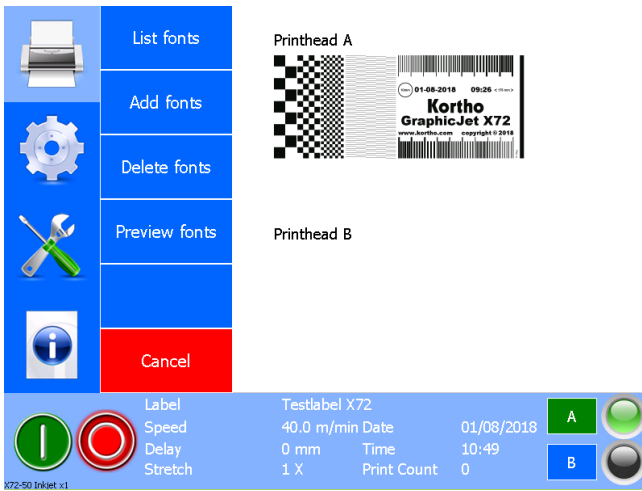

Fig. 9.4 Font menu

List fonts

This function provides a list of all fonts added to the system by the user. These can also be removed, unlike the standard fonts. The standard fonts cannot be removed.

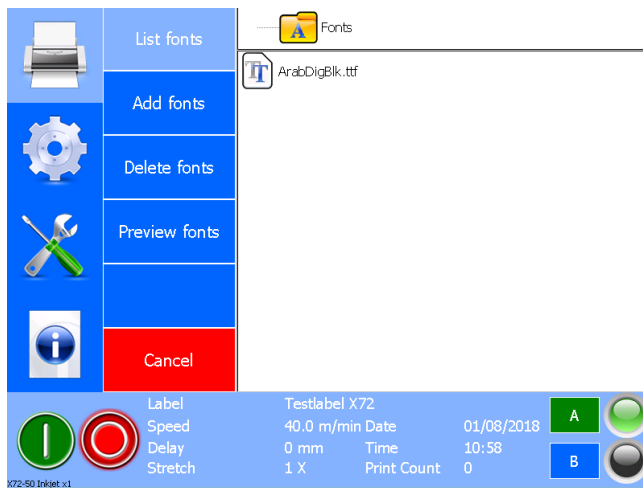

Fig. 9.5 List fonts menu

The fonts shown on screen can be used while designing a label with the on-board label design editor.



Beware:

When using the Window driver it is important only to use the fonts that are implemented into the driver: Arial Black, Century Gothic, Liberation Sans, Liberation Serif and Tahoma. If a font is used that is not pre-installed in the driver, the text will be send to the printer as a bitmap, i.e. as fixed text.



Note:

The printer is supplied with a set of internal fonts installed. The fonts shown in the picture above are *NOT* part of the pre-installed fonts. If fonts are added, they will also be shown on the *Preview fonts* screen (see below *Font preview*).

Delete fonts

This feature allows fonts, which have been added by the user, to be removed from the printer. Since fonts take up a lot of memory space, it is wise to delete unused fonts.

1. Touch the *Delete fonts* button and the following screen will be shown.

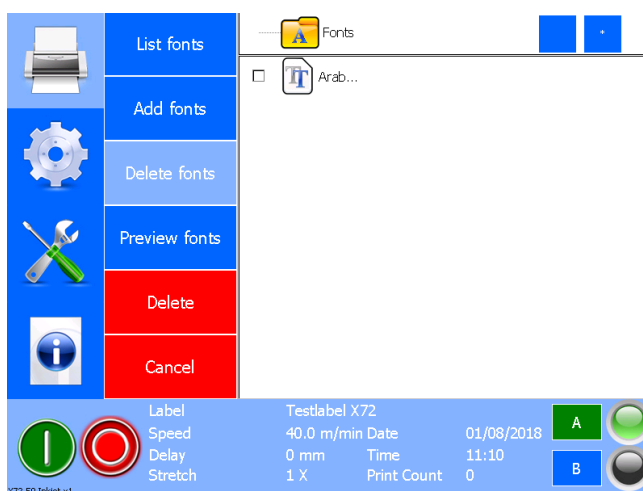

Fig. 9.6 Delete fonts menu



Note:

The printer is supplied with a set of pre-installed fonts. The pre-installed fonts cannot be removed from the printer and are *not* shown on the screen shown above.

2. Touch the selection box of the font or fonts that need(s) to be removed. With the buttons in the right hand top corner, one can select or deselect all of them.
3. Touch the *Delete* button to remove the font or fonts from the printer. The following screen will be displayed.

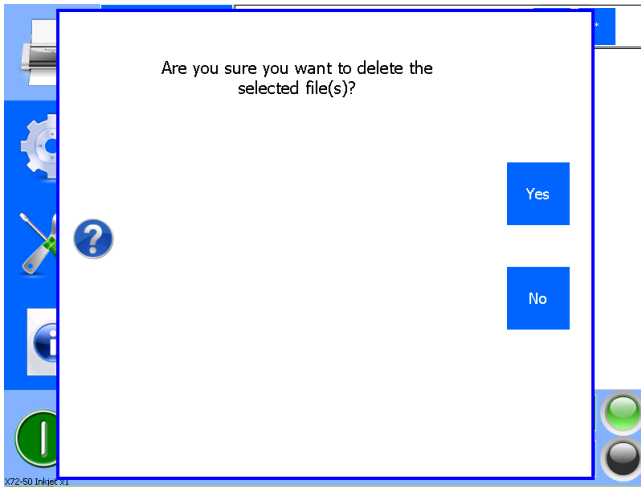

Fig. 9.7 Delete files(s), are you sure?

4. Press *Yes* to confirm the removal of the font and to return to the *Delete fonts* menu.
5. Another font can be deleted or alternatively touch *Cancel* to return to the *Print, Locale files* menu.



Note:

When a font is deleted, the system should be restarted to have affect.



Beware:

When a font is removed that is used in a label, a different font will be used when printing that label. As a result, the printed label will look different than during the design of the label. Put back the deleted font or update the corresponding label to avoid problems.

Add fonts

This function makes it possible to add fonts to the printer.

1. Mount a USB thumbdrive containing the true type (TTF) font files.
2. Touch the *Add fonts* button. The content of the USB thumbdrive will be shown.

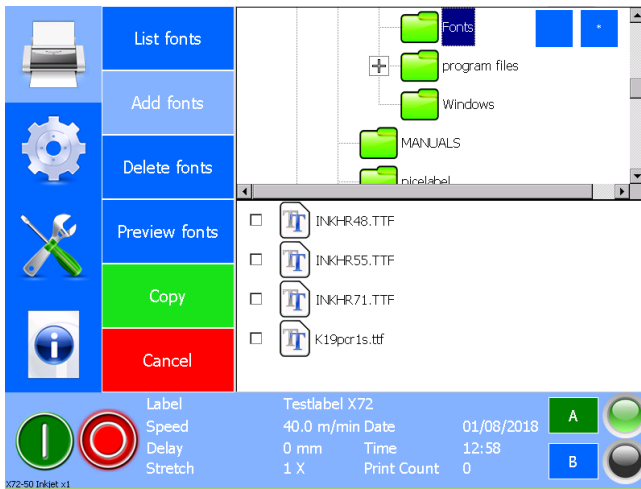

Fig. 9.8 Add fonts menu

3. Select the folder containing the font files in the folder structure in the top part of the screen.
4. Select the font(s) in the bottom part of the screen by selecting the selection box or boxes or use the buttons in the top right hand screen to select or deselect all.
5. Touch the *Copy* button to copy the font(s) to the printer.
6. If the copy process has been successful the following screen will be shown

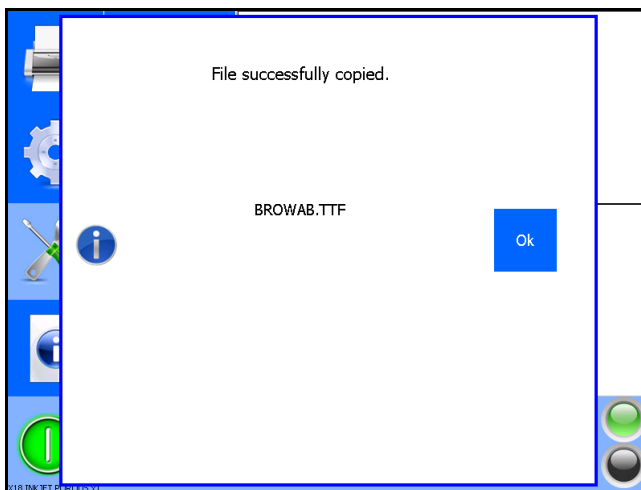

Fig. 9.9 File copy successful

7. Press *Ok* to leave the screen and to return to the *Copy* menu.
8. Another font can be copied or alternatively touch *Cancel* to return to the *Print, Local files* menu.



Note:

The copied font can be used without restarting the system.

Font preview

With this function, one can see a preview of any TTF font available in the system. This includes the pre-installed fonts and the user added fonts..

1. Touch the *Preview fonts* button. The following screen will be shown.

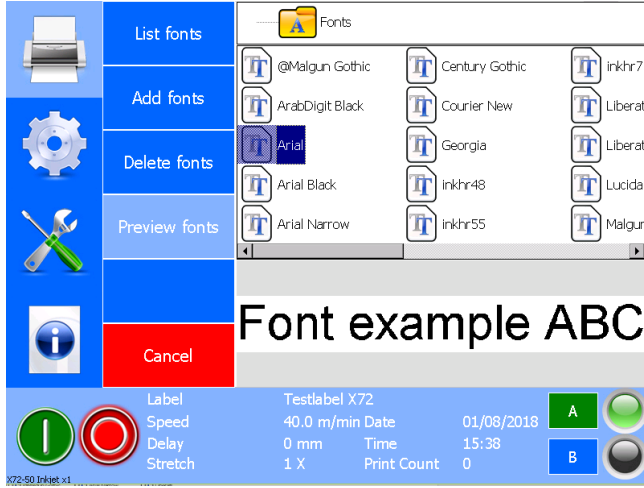

Fig. 9.10 Preview font menu

2. Select a font which you want to preview.

Cancel

Touch *Cancel* to return to the Diagnostics menu.

9.1.3 Test

This function can be used to make test prints to verify and to optimize the print quality. This can be done with the current label but it is better to use a *Test label*, see section 9.1.1.

Touch *Test* to enter the menu that contains the print test functions.

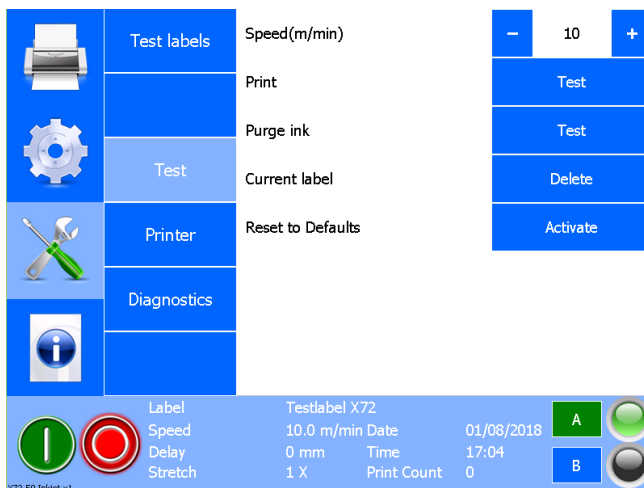

Fig. 9.11 Test menu

Speed

Touch +/- to alter the print speed. Alternatively touch the value shown and enter the Speed value through the numerical keyboard. At the right print speed the Kortho test label has a length of 100mm (X18 / X54) or 175mm (X72).

Print

Touch the *Test* button to make a single print. It does not matter whether the system is in paused or standby mode

Purge ink

This procedure is meant to test the piezo elements of the printhead or to clear the nozzles when the prints contain minor flaws.



Beware:

When performing the Purge procedure, a full height black label will be printed. Hold paper tissues in front of the printhead, while performing this procedure, to collect the ink.

Current label

Press the *Delete* button behind *Current label* to delete the currently selected label. To continue printing, a different label must be selected. This may be necessary if a label has become corrupt and the direct selection of another label does not work.

Reset to defaults

Press the *Activate* button to restore the factory settings of the printer. This means that the printer settings are changed to their default values. No labels are removed from the system. The print buffer, which contains the bitmap to be printed, is cleared. You therefore have to check all settings and change them if required. In addition, one must also select a label for printing. Use this function only if you have saved all settings with the report function or have defined them in another way.

There is also an alternative way to default the printer. This alternative way should be used if it is not possible to use the standard way to reset to defaults. See appendix K for the details.

9.1.4 Printer

Touch the *Printer* button to open the Printer menu.

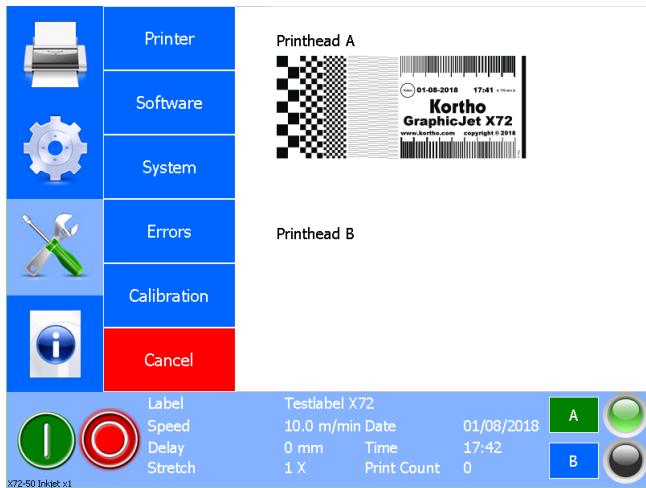

Fig. 9.12 Service - Printer menu

Printer

Touch the *Printer* button to show some diagnostics values of the printer.

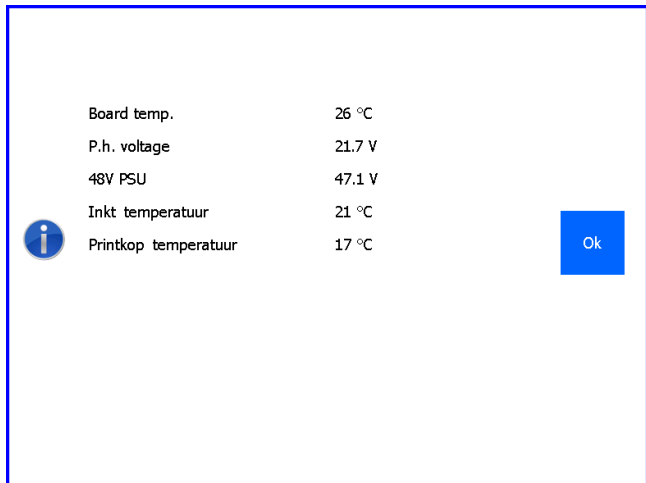

Fig. 9.13 Printer diagnostics screen

Board temperature – the temperature of the main board that’s located in the control unit. It is measured by a sensor on the main board.

Printhead voltage – indicates the voltage applied to the printhead.

X18: Factory calibrated at 35V. The voltage can be recalibrated, but should not be necessary. The X18 printhead has built-in temperature compensation.

X54: Factory set to approximately 35V. This cannot be changed. The X54 print head internally adjusts the voltage and compensates for the temperature for the best print result.

X72: The value depends on the calibration, the rank voltage of the print head, the offset voltage, ink type, ink temperature and ambient temperature. This voltage is automatically adjusted by the X72 headboard for the best print result.

48V PSU – indicates the voltage supplied by the 48V power supply.

Ink temperature [X72] – temperature of the ink measured inside the X72 printhead

Printhead temperature [X72] – temperature of the X72 printhead.

Touch the *Ok* button to return to the Service-Diagnostics-Printer menu.

Software

Touch the *Software* button to show the installed firmware and software versions.

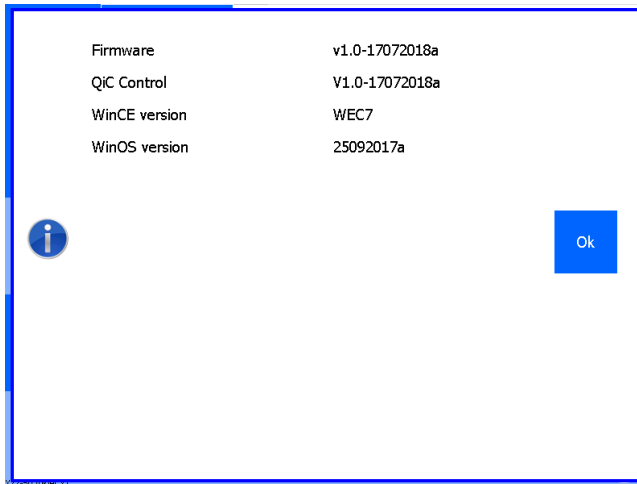

Fig. 9.14 Software and firmware version screen.

Firmware – the software which makes this a X-series printhead controller.

QiC Control – the software that creates the user interface.

WinCE – the software version of the Windows CE version running on the hardware.

WinOS Version - the build version of the CE image that is used.

Touch the *Ok* button to return to the Service – Diagnostics - Printer menu.

System

Touch the *System* button to show information about the system.

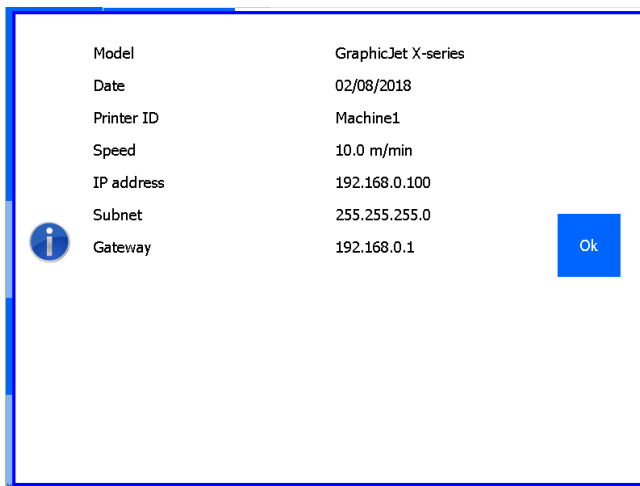

Fig. 9.15 System information screen

Model – model of the coding unit connected to the control unit.

Date – system date of the control unit.

Printer ID – the printer ID as defined by the user.

Speed – the speed at which the system will make a print (without encoder).

IP Address/Subnet/Gateway – the set network settings of the control unit.

Touch the *Ok* button to return to the Service – Diagnostics - Printer menu.

Error

Touch the *Error* button to show the 15 most recent errors/warnings since the printer was switched on.



Beware:

When the control unit is rebooted or switched off the error list will be cleared.



Note:

To view errors 7 to 15 touch the screen at the bottom, between numbers and scroll bar, and drag the messages upwards. This will scroll them into view.



Note:

Behind the error message is a counter which indicates how many times the same error occurred one after the other.

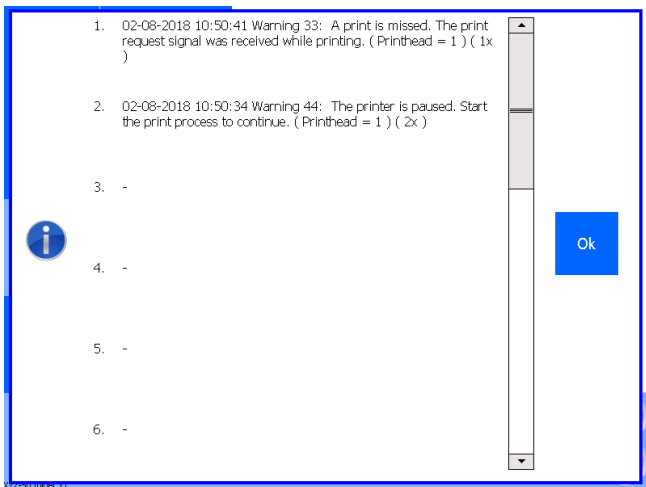

Fig. 9.16 Error-Warning list

Touch the *Ok* button to return to the Diagnostics-Printer menu.

Calibration [X18 / X72]

In this menu the printhead voltage calibration values can be set.



Beware:

The system could get disrupted once the calibration values are not properly set. The calibration procedure should only be performed by qualified personnel of Korthofah BV or a local distributor, which is designated by Korthofah BV.

Cancel

Touch the *Cancel* button to return to the Diagnostics main menu.

9.1.5 Diagnostics

Touch *Diagnostics* to enter the diagnostics menu in which various system checks can be performed.



Beware:

System Diagnostics should only be run when the system is paused. Only a trained service engineer should run these tests.

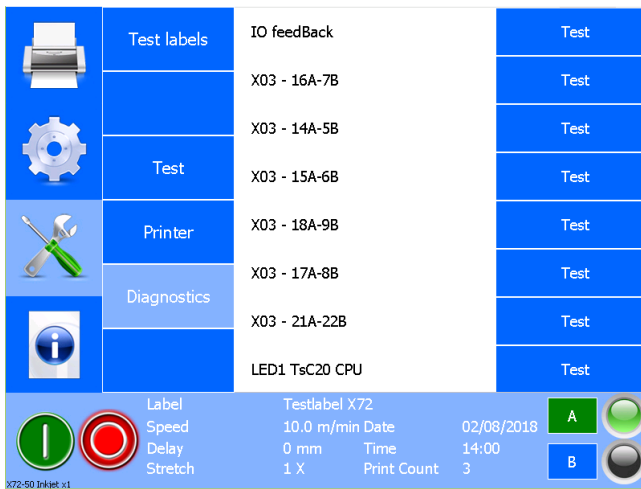

Fig. 9.17 Diagnostics menu

IO feedback - This button is used to test the main external input signals (X03-19A-20B, Product detection, Dip switches on the motherboard, X03-11A-2B, X03-10A-1B, X03-13A-4B, Print signal and Encoder signals (channels A and B)..

The external inputs can be checked using a service tool or attached peripheral device. To test the external inputs:

1. Select *IO Feedback* and activate the attached peripheral device (sensor or other device) or
2. Use a service device to activate the inputs.

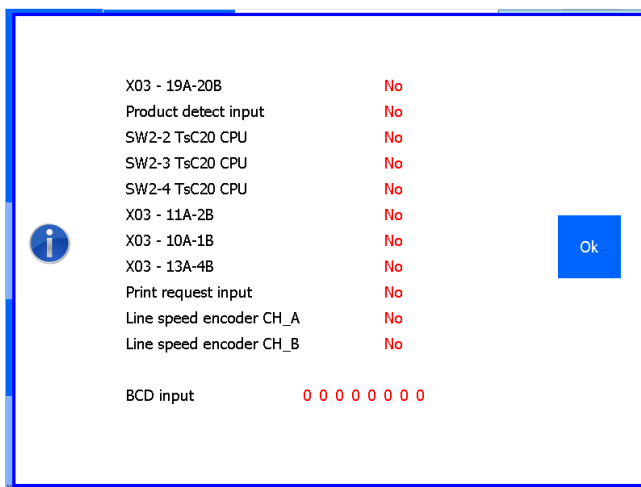

Fig. 9.18 IO feedback screen

Output X03-16A-7B – The output is activated for 2 seconds. This can be used to test whether this output is functioning. The output can be monitored on the host machine or a separate service tool. By default, this is the Busy output.

Output X03-14A-5B – The output is activated for 2 seconds. This can be used to test whether this output is functioning. The output can be monitored on the host machine or a separate service tool. By default, this is the Ink out output.

Output X03-15A-6B – The output is activated for 2 seconds. This can be used to test whether this output is functioning. The output can be monitored on the host machine or a separate service tool. By default, this is the Ink low output.

Output X03-18A-9B – The output is activated for 2 seconds. This can be used to test whether this output is functioning. The output can be monitored on the host machine or a separate service tool. By default, this is the General error output..

Output X03-17A-8B – The output is activated for 2 seconds. This can be used to test whether this output is functioning. The output can be monitored on the host machine or a separate service tool. By default, this is the Spare 1 output. Spare 1 has no function connected to it.

Output X03-21A-22B – The output is activated for 2 seconds. This can be used to test whether this output is functioning. The output can be monitored on the host machine or a separate service tool. By default, this is the Spare 2 output. Spare 2 has no function connected to it.

LED1 TsC20 CPU – LED1 on the controller board are activated for 2 seconds.

Touch the *Ok* button to return to the Diagnostics menu.

9.1.6 Graphics

Touch *Print – Local files - Graphics* located at the left side of the screen. The following screen is shown.

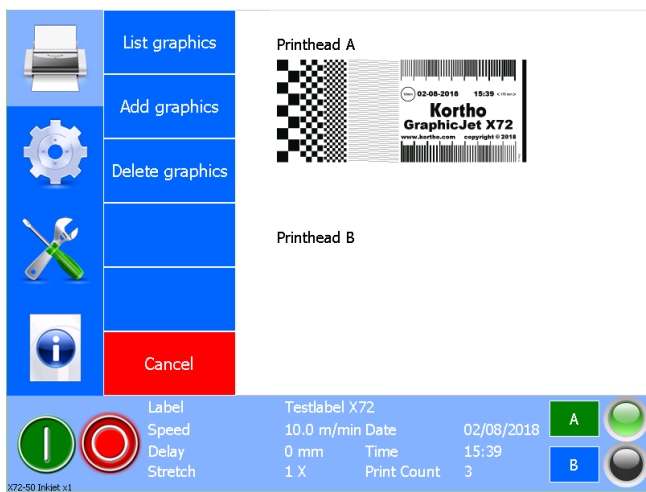

Fig. 9.19 Graphics menu

List graphics

This function lists all graphics currently installed in the printer. These graphics are available to be used in the on-board label editor.

1. Druk op de afbeelding om het voorbeeld onder in het scherm te zien.

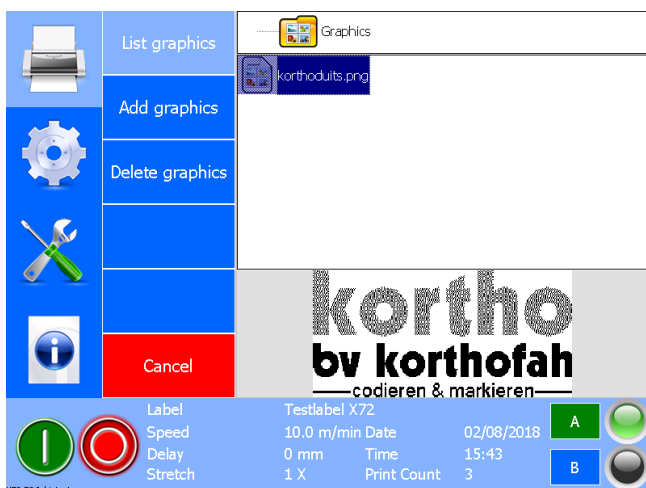

Fig. 9.20 Graphic preview

Delete graphics

This function makes it possible to delete graphics from the printer.

2. Touch the Delete fonts button and the following screen will be shown.



Fig. 9.21 Delete graphics menu

3. Select the graphic to be deleted by touching the checkbox to the left of the graphic. There is a so-called 'check mark' in it. With the blue buttons at the top right of the screen (2 and 3) all images can be deselected / selected at the same time.
4. Touch the *Delete* button to remove the selected graphic(s) from the printer, the following screen will be displayed.

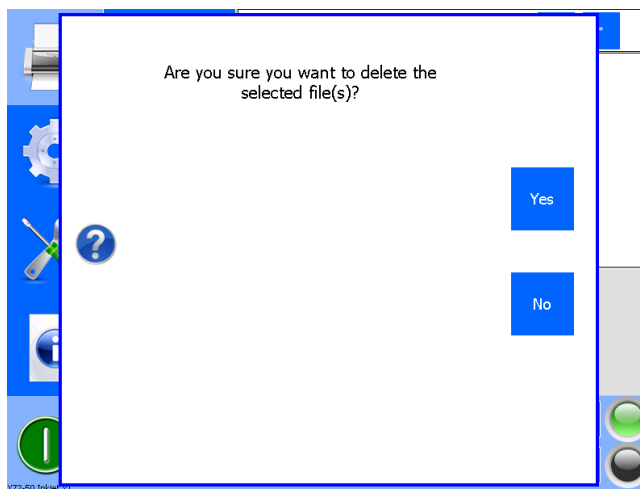

Fig. 9.22 Delete graphic, are you sure?

5. Press *Yes* to confirm the removal of the graphic(s) and to return to the *Delete graphics* menu.
6. Another graphic can be deleted or alternatively touch *Cancel* to return to the *Print – Local files* menu.



Note:

Adding Graphics to a label will copy the contents of the graphic in the label design. Deleting a Graphic has no impact on the labels containing the graphics.

Add graphics

This function makes it possible to add graphics to the printer.

1. Mount a USB thumb drive containing the font files.
 - a. Files need to be BMP or PNG
 - b. Colour files are automatically converted to black and white when placing the graphic into the label editor.
 - c. The size of the graphic can be changed in the label editor
 - d. The best print result is achieved when the graphic is pre-processed on a PC so they will have the optimum size, resolution and colour (B/W). The graphics will also take up the least amount of memory in the controller.
 - i. Optimum resolution is 185DPI [X18] or 180DPI [X54 / X72]
 - ii. Optimum height is max 17.5mm @185DPI [X18] or 53.8mm @180DPI [X54] or 71.8mm @180DPI [X72]
 - iii. Optimum amount of colours is 2 (black and white)
2. Touch the *Add graphics* button and the content of the USB thumbdrive will be shown.

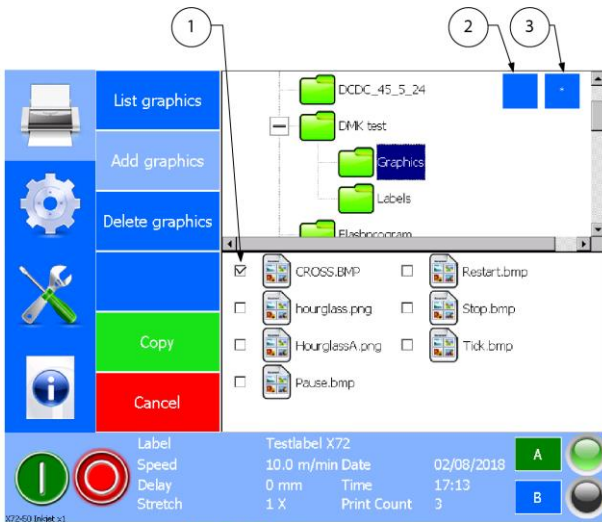

1. Selected graphic
2. Deselect all graphics
3. Select all graphics

Fig. 9.23 Add graphics menu

3. Select, in the top area, the folder containing the graphics files.
4. Select the graphic(s) to be added by touching the checkbox to the left of the graphic. There is a so-called 'check mark' in it. With the blue buttons at the top right of the screen (2 and 3) all images can be deselected / selected at the same time.
5. Touch the *Copy* button to copy the graphic to the printer. During the copy process, an hourglass is shown. If a graphic already exists, one can overwrite the graphic or skip it.
6. After copying is complete, a graphic can be added / copied immediately, or alternatively, press *Cancel* to return to the main menu *Print - Local files*.

Cancel

Touch *Cancel* to return to the *Print - Local files* menu.

9.2 Information

Touch the *Information* icon located at the bottom of the screen.

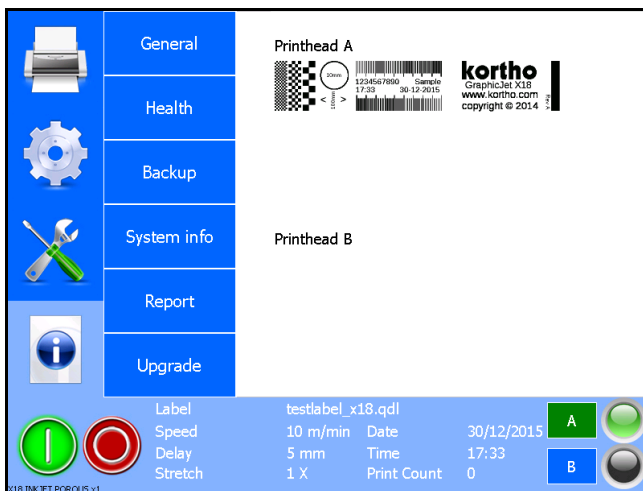

Fig. 9.24 Information menu

9.2.1 General

Touch the *General* button to display the information screen containing the general information.

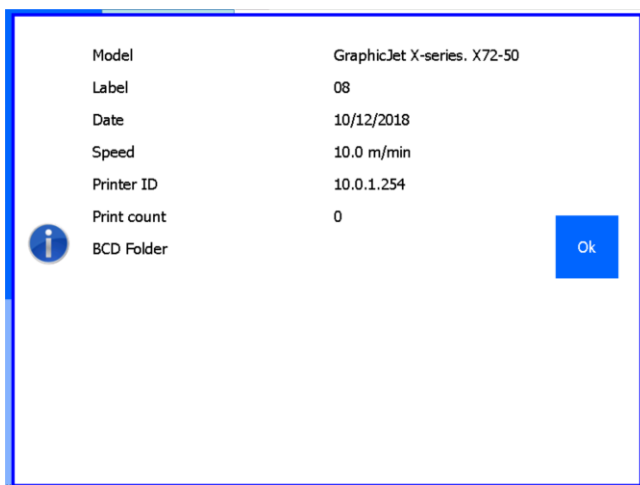

Fig. 9.25 General information screen

Model - model of the inkjet coding unit connected to the control unit.

Label - the name of the currently loaded label.

Date - system date of the control unit.

Speed – the set speed when using the internal speed setting.

Printer ID – the printer ID as defined by the user.

Print count - the total number of prints made with the current label, without changing to another label in between.

BCD Folder – the name of the folder from which the labels to print are selected from when the BCD mode is active

Touch the *Ok* button to return to the Information menu.

9.2.2 Health

Touch the *Health* button to show printing statistics.

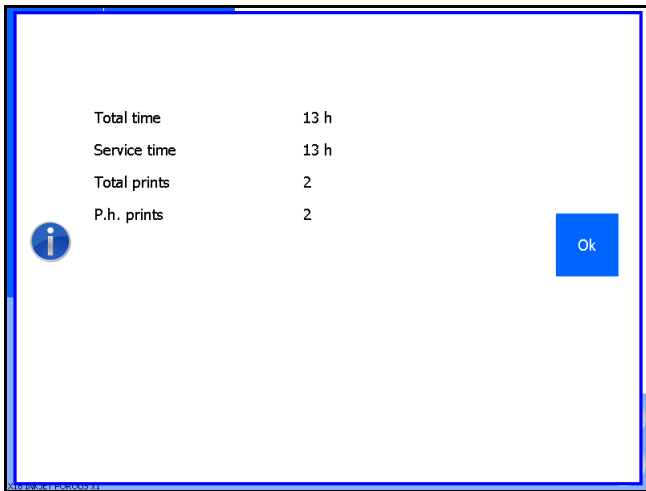

Fig. 9.26 Health screen

Total time - the total time the system has been switched on.

Service time - the time since the last service. During a service visit this time should be reset.

Total prints - the total number of prints the system has made.

P.h. prints - the number of prints that the currently used system has made.

Touch the *Ok* button to return to the Information menu.

9.2.3 Backup

This function backups the labels on the system into a folder onto a connected USB thumbdrive.



CAUTION:

Do not use an extension cable for connecting the USB thumbdrive to the controller, but place the USB thumbdrive directly in the controller. Using an extension cable can cause EMC interference.

1. Insert a USB thumbdrive and wait for 4 seconds so it can be detected and mounted.
2. Touch the *Backup* button.
3. Enter a suitable name for the backup folder. (at least two characters)



Fig. 9.27 Enter Backup name

4. Touch the *Enter* button to save the backup.

5. If the name already exists a file overwrite message will be displayed. Touch *Yes* and the backup file will be overwritten. Touch *No* and the backup operation will be cancelled. The created folder name on the USB thumbdrive is as follows: KorthoBackup_03082018-0928_XXXX. The name is built up like this: KorthoBackup_DDMMYYYY-HHMM_entered name.

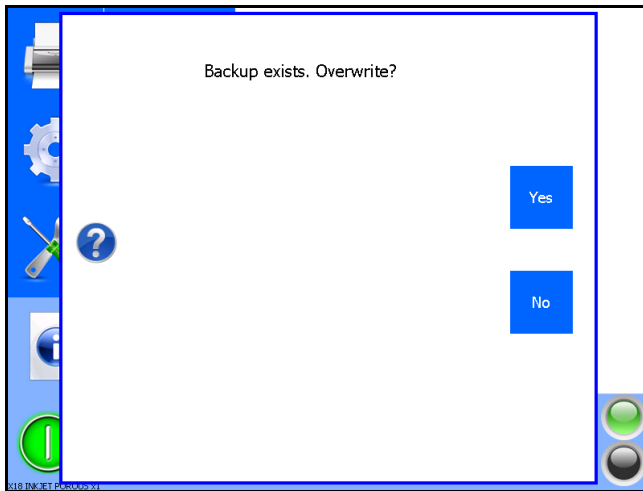

Fig. 9.28 Backup overwrite

6. While creating the backup folder and backing up the labels a timer icon will be shown on screen.

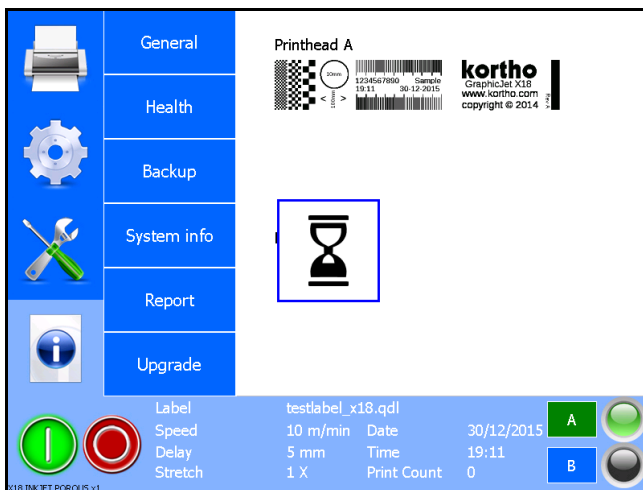

Fig. 9.29 Backup in progress

7. Wait until the message "Backup completed successfully" appears on screen.

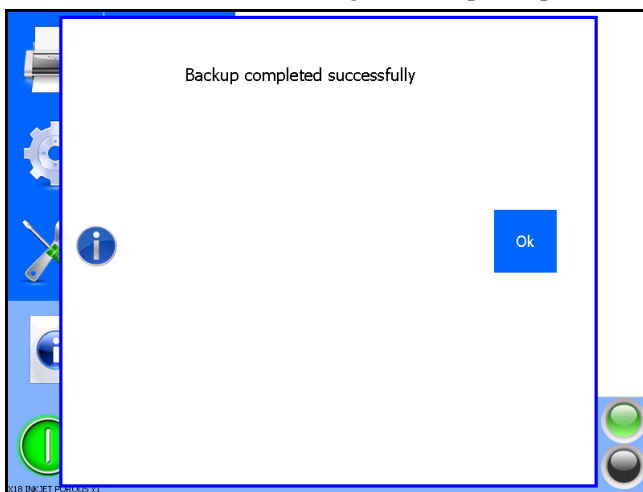

Fig. 9.30 Backup finished

8. Touch *Ok* to confirm and to return to the previous menu.
9. Remove the USB thumbdrive.

9.2.4 System Info

Touch the *System* button to display the information screen containing the system information.

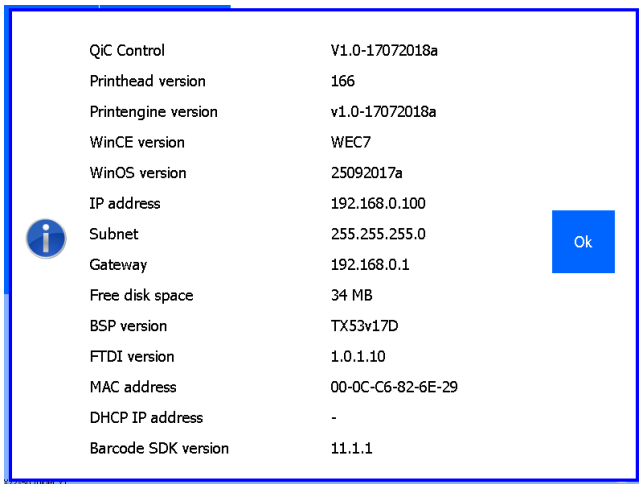

Fig. 9.31 System information screen

QIC Control – the software that creates the user interface.

Printhead version – the version of software that runs on the head board.

Print engine version – the version of the software that runs on the control unit.

WinCE version – the software version of Windows CE.

WinOS version - the build version of the image that is used to flash the user interface hardware.

IP Address/Subnet/Gateway – the set network address of the control unit.

Free disk space – the space that’s still available for saving new labels, fonts and graphics in the control unit.

BSP version – Board Support Package version

FTDI version – version of the internal FTDI driver

MAC address – het fysieke adres van de ethernetkaart PHY chip

DHCP IP address – if DHCP is activated, the IP address assigned by the DHCP server.

Barcode SDK version – version of the SDK software for the barcode engine

Touch the *Ok* button to return to the Information menu.

9.2.5 Report

This function generates a service report containing the printer settings and statistics. This service report can be opened as a text file.

When seeking assistance from Korthofah BV or your local distributor it is recommended that this is submitted.



CAUTION:

Do not use an extension cable for connecting the USB thumbdrive to the controller, but place the USB thumbdrive directly in the controller. Using an extension cable can cause EMC interference.

To generate a report:

1. Insert a USB thumbdrive and wait for 4 seconds so it can be detected and mounted.
2. Touch the *Report* button.
3. Enter a suitable <name> for the report (two characters minimum) or to cancel the operation simply do not enter a name and press enter.



Fig. 9.32 Enter report name

4. Touch the *Enter* button to save the report.
5. If the file name already exists a file overwrite message will be displayed. Touch *Yes* and the report files will be overwritten. Touch *No* and the report operation will be cancelled.



Fig. 9.33 Report overwrite

6. While creating the report file a timer icon will be shown on screen.

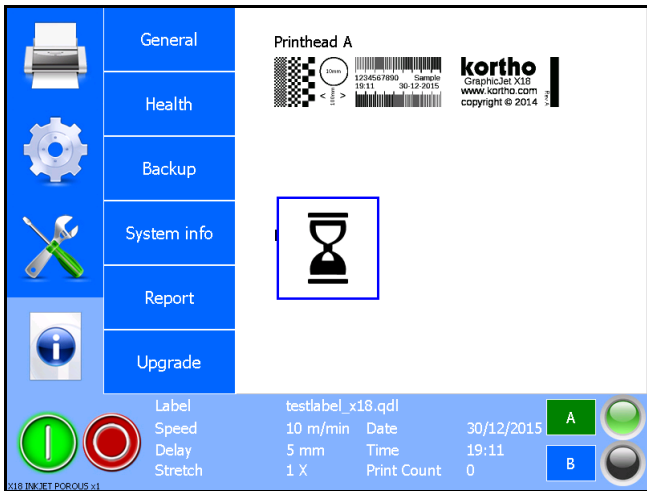

Fig. 9.34 Creating report in progress

7. Wait until the message that the Report Saved appears on screen.

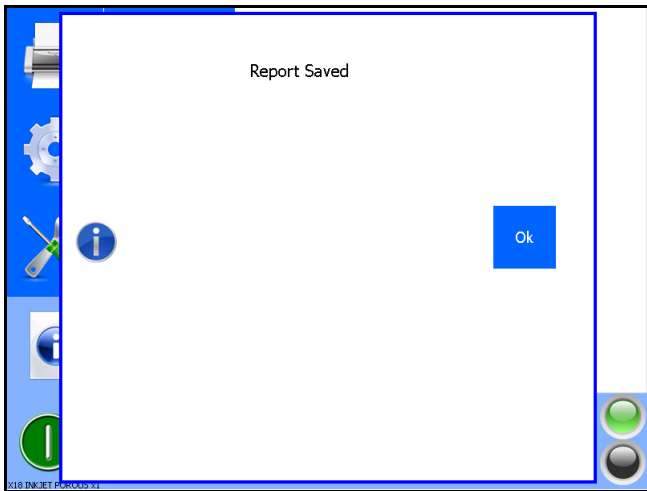

Fig. 9.35 Report saved

8. Touch *Ok* to confirm and to return to the previous menu.
9. Remove the USB thumbdrive, it will contain a file with the name "KorthoReport_DDMMYYYY-HHMM_xxxx. DDMMYYYY is the date on which the report was made, HHMM the time the report was made and xxxx is the name one entered.

9.2.6 Upgrade

This function is used to upgrade the core software of the system (QiC Control, Print engine and Printhead driver).

**CAUTION:**

Do not use an extension cable for connecting the USB thumbdrive to the controller, but place the USB thumbdrive directly in the controller. Using an extension cable can cause EMC interference.

**Note:**

Make sure the system is in Pause mode, if not an error message will be generated.

To upgrade the software:

1. Insert a USB thumbdrive that contains the upgrade file (TsC20DDMMYYx.CAB), located in the root of the drive.

**Note:**

Make sure that only the upgrade file of the software version that should be installed is present in the root of the USB thumbdrive. Otherwise there is a chance that the wrong version will be installed.

2. Touch the *Upgrade* button, the following screen will be displayed.

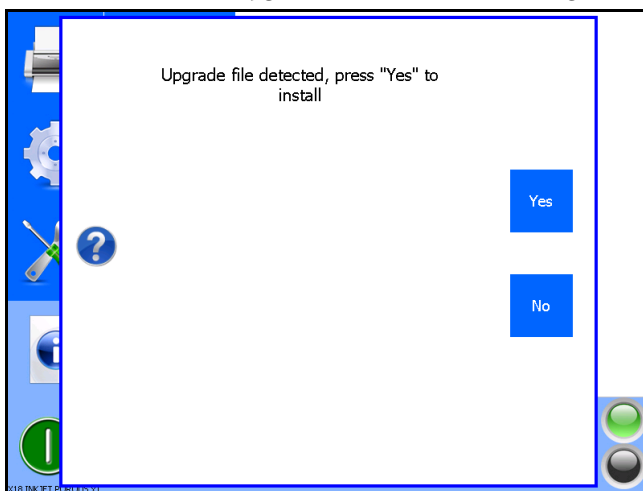

Fig. 9.36 Upgrade files detected screen

3. Touch the *Yes* button to start the upgrade process.

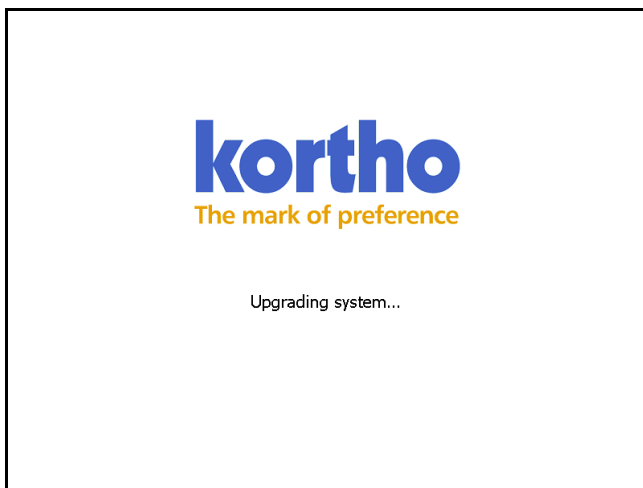

Fig. 9.37 Upgrade in progress screen

4. The system will upgrade in less than 20 seconds.
5. Restart the system to finish the installation process (switch off and on again after 10 seconds).). In later versions, the controller will reboot by itself so that the controller does not require a power toggle.

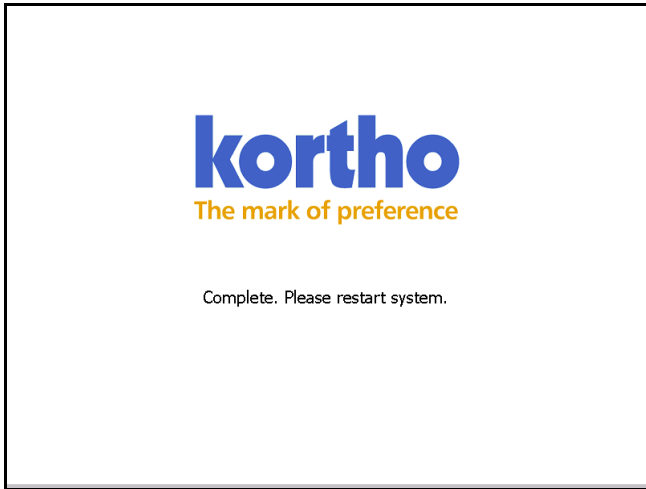

Fig. 9.38 Upgrade finished screen

The firmware of the coding unit will, if required, automatically be upgraded after the upgrade process of the controller has been finished and the controller has been switched off and on again. One has to confirm twice by pressing Ok during the firmware upgrade of the coding unit. Switch off and on again after 10 seconds to activate the new firmware in the coding unit.



Beware:

Do not switch of the controller during the upgrade process.

9.3 Fault finding

9.3.1 Control unit

Fault indication	Symptom(s)	Action(s)
Control unit does not power up.	The user interface remains dark	<p>Check whether the mains voltage is present.</p> <p>Check whether power cable is properly connected to the control unit.</p> <p>Check whether the power cable is not damaged.</p> <p>Check whether ON-OFF switch is in the position I.</p> <p>These actions should only be performed by qualified personnel.</p> <p>Disconnect power cable (X1) from mains power supply first!</p> <p>Check the fuses in the power entry module (X01). The LED's beside the fuses on the power supply board should be lit.</p> <p>Check the fuses on the power supply board. When a LED beside the fuse on the power supply board is not lit, the fuse is blown.</p> <p>Check whether internal mains wiring is connected properly.</p> <p>Check whether 48VDC is present and the processor board wiring is connected properly.</p> <p>Check whether the backlight cable of the user interface panel is properly connected.</p> <p>Check whether user interface panel-flat cable is properly connected and undamaged.</p> <p>Check whether a "burning smell" is present in control unit. If so, contact your local dealer.</p>
Control unit does not boot up.	Touch screen is backlit (white screen)	<p>These actions should only be performed by qualified personnel.</p> <p>Disconnect power cable (X1) from mains power supply first!</p> <p>Check if the data cable of the Touch screen is properly connected.</p> <p>Check the power supply of the CPU board.</p> <p>Check the fuses in the power entry module (X01). The LED's beside the fuses on the power supply board should be lit.</p> <p>Check the fuses on the power supply board. When a LED beside the fuse on the power supply board is not lit, the fuse is blown.</p> <p>Check whether a "burning smell" is present in control unit. If so, contact your local dealer.</p>
The label cannot be downloaded to the system.		<p>The label file on the USB thumbdrive may be corrupt. Ensure when transferring information that the flash device is removed properly from the PC/laptop.</p> <p>Re-create the PRN file and try again. Alternatively create the complete label again and try to download it again.</p> <p>If the problem remains contact technical support.</p>

DIAGNOSTICS / TROUBLESHOOTING

The font required cannot be downloaded to the system.		The font is be too large, a message will be displayed. The file on the USB thumb drive may be corrupt. Ensure when transferring from a PC the USB thumbdrive is removed properly.
The label cannot be selected for printing		The label file stored in the label memory may be corrupt, download again.
The printer is not printing on request.		System is in pause mode (the red indicator is lit – warning is displayed on screen). The number of prints has reached the value set in print count (the green status LED on the coding unit is flashing, the status screen shows the print count x / x) Print request sensor (or cable) is defect or not sensing the product/mark. System is in error mode (the orange LED is displayed on screen and general alarm output is active).
The ink has been refilled but the setting is still showing low.	Low ink output is active and status LED is orange.	Check whether the ink level sensor is working properly.
Printer is showing an error or warning message.	LED is orange	View the error/warning list for more information (Diagnostics - Printer – Errors).
The user interface is only showing a blank screen.		Reset the control unit, by switching the control unit off and after 10 seconds on again.

9.3.2 Coding unit

Fault indication	Symptom(s)	Action(s)
After refilling the ink the system, the system does not print anymore.		Assuming the control unit is not causing any problems, see subsection 9.3.1: Prime the coding unit, to remove the air out of the system.
The system is not printing.		Assuming the control unit is not causing any problems, see subsection 9.3.1: Check whether the control unit indicates an error message. If so, remove the cause of the error and reset the error message. Check if all cables are connected properly. Check whether a label is selected. Check whether the system is in run mode. Check whether a print signal has been received by the control unit (counter should be updated after a print signal has been applied). Check whether the photocell detects the substrate (LED on

DIAGNOSTICS / TROUBLESHOOTING

		<p>photocell should switch off and on).</p> <p>Use the Diagnostic menu to determine whether the system detects the print request.</p> <p>Make sure there is enough ink in the ink reservoir (only refill when the ink low LED is lit!).</p> <p>Prime the coding unit, to remove the air out of the system.</p> <p>Purge the system, to see if the printhead is still ok. If not, replace the head filter and check the print again.</p> <p>If all else fails, replace the printhead if required.</p>
White lines are shown in the print direction		<p>One or more nozzles are blocked or partially blocked. Clean the front plate of the printhead by squirting some cleaner to the front plate (do not rub against the front plate. this might damage the front plate and/or dirt might be pushed into the nozzles which will cause a permanent blockage of these nozzles).</p> <p>Prime the coding unit, to remove the air out of the system.</p> <p>Make sure the ink tube clamps are properly placed [X54].</p> <p>Purge the system, to see if the printhead is still ok. If not, replace the head filter and check the print again.</p> <p>If all else fails, replace the printhead if required.</p>
Vertical white lines are shown in the print.		<p>When using the internally set speed:</p> <p>The set speed doesn't matches the actual speed and/or the actual speed is fluctuating too much. Set the speed at the right value and/or make sure the substrate is moving at a stable speed.</p> <p>When using an external encoder:</p> <p>Make sure the specs of the encoder match the required system specs.</p> <p>Check whether the encoder is in constant contact with the substrate/conveyer belt and if there is no slip between the encoder wheel and the substrate/conveyor belt.</p> <p>The actual speed is fluctuating too much. Make sure the substrate is moving at a stable speed.</p>
Print missed.		<p>Ensure that production line speed has not been increased.</p> <p>Check the position of the print sensor.</p> <p>Check the sensitivity setting of the print sensor.</p> <p>Check if the print request sensor detects the product multiple times.</p>
The lower part of the print is missing	Ink is dripping off the bottom of the coding unit housing	<p>Check whether the ink reservoir is at the right level.</p> <p>Check whether the ink reservoir is levelled.</p> <p>Check whether the front plate is free of debris. Clean the front plate of the printhead by squirting some cleaner to the front plate (do not rub against the front plate. this might damage the front plate and/or dirt might be pushed into the nozzles which will cause a permanent blockage of these nozzles).</p> <p>Check whether the ink level in the ink system is not too high, if so, remove some ink from the ink system.</p>
The upper part of the print is missing		<p>Check whether the ink level in the ink system is not too low, if so, refill the ink system.</p> <p>Check whether the ink reservoir is at the right level.</p>

		<p>Check whether the ink reservoir is levelled.</p> <p>Prime the coding unit, to remove the air out of the system.</p> <p>Check whether the front plate is free of debris. Clean the front plate of the printhead by squirting some cleaner to the front plate (do not rub against the front plate. this might damage the front plate and/or dirt might be pushed into the nozzles which will cause a permanent blockage of these nozzles).</p>
--	--	---

9.3.3 Print request sensor

Fault indication	Action(s)
Sensor does not detect the passing product.	<p>In case of a photocell:</p> <ul style="list-style-type: none"> - Check whether the lens (front side) of the photocell is clean. - Check whether the sensitivity of the photocell is properly set. - Check whether the photocell connector (X03) is properly connected to the control unit. - Check whether the photocell does not detect anything in the background. Normally, the LED indicator on the photocell is off if no substrate is present. - Check I/O feedback in Diagnostics to determine whether the system detects the print request. <p>In case of a switch/relay/PLC contact:</p> <ul style="list-style-type: none"> - Check whether the interface cable connector (X03) is properly connected to the control unit. - Check whether the signal is really generated. - Check whether all wiring between sensor and control unit is mounted correctly. - Check I/O feedback in Diagnostics to determine whether the system detects the print request.

9.3.4 Encoder

Fault indication	Symptom(s)	Action(s)
Encoder wheel does not turn / Encoder wheel slips.	<p>No printout / Printout not at the correct length.</p> <p>Vertical white lines in the printout.</p>	<p>Check whether the lever spring is set to provide enough tension.</p> <p>Check whether the encoder mounting bracket is securely mounted.</p> <p>Check whether the O-rings are in good working condition.</p>

9.4 Error/warning messages

When problems occur the system will generally report an error message. The error message will be displayed on screen. As example see Fig. 9.39. Depending on the kind of error, the alarm output will also be set. Besides error messages the system will also report several warnings.

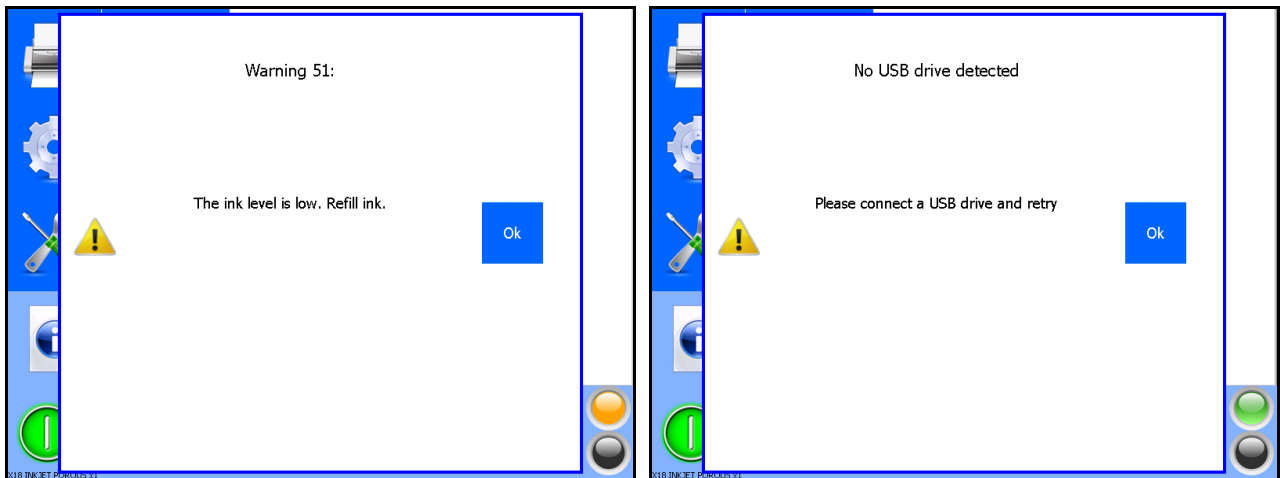

Fig. 9.39 Error/warning message

For a list of all the errors / warnings that can be generated, see Appendix G.

9.5 Poor print quality

9.5.1 General issues

Fault indication	Action(s)
<p>Poor print quality in general.</p>	<p>Make sure there is enough ink in the ink reservoir (only refill when the ink low LED is lit!).</p> <p>Check whether the ink reservoir is at the right level.</p> <p>Check whether the ink reservoir is levelled.</p> <p>One or more nozzles might be blocked or partially blocked. Clean the front plate of the printhead by squirting some cleaner to the front plate (do not rub against the front plate, this might damage the front plate and/or dirt might be pushed into the nozzles which will cause a permanent blockage of these nozzles).</p> <p>Prime the coding unit, to remove the air out of the system.</p> <p>Purge the system, to see if the printhead is still ok. If not, replace the head filter and check the print again.</p> <p>If all else fails, replace the printhead if required.</p> <p>When using fixed speed:</p> <p>The set speed doesn't matches the actual speed and/or the actual speed is fluctuating too much. Set the speed at the right value and/or make sure the substrate is moving at a stable speed</p> <p>When using an external encoder:</p> <p>Make sure the specs of the encoder match the required system specs.</p> <p>Check whether the encoder is in constant contact with the substrate/the conveyor belt and if there is no slip between the encoder wheel and the substrate/the conveyor belt.</p> <p>The actual speed is fluctuating too much. Make sure the substrate is moving at a relative stable speed.</p>

<p>Labels are only partially printed.</p>	<p>Make sure there is enough ink in the ink reservoir (only refill when the message to refill appears on screen!). Check whether the ink reservoir is at the right level. Check whether the ink reservoir is levelled. Check whether the ink level in the ink system is not too high, if so, remove some ink from the ink system. One or more nozzles might be blocked or partially blocked. Clean the front plate of the printhead by squirting some cleaner to the front plate (do not rub against the front plate, this might damage the front plate and/or debris might be pushed into the nozzles which will cause a permanent blockage of these nozzles). Prime the coding unit, to remove the air out of the system. Purge the system, to see if the printhead is still ok. If not, replace the head filter and check the print again. If all else fails, replace the printhead if required.</p>
<p>The labels are not being printed at the correct size or position.</p>	<p>Check whether the delay setting is either too low or too high. Check whether the substrate is moving at a relative stable speed. When using fixed speed : The set speed doesn't matches the actual speed and/or the actual speed is fluctuating too much. Set the speed at the right value and/or make sure the substrate is moving at a stable speed When using the external encoder: Make sure the specs of the encoder match the required system specs. Check whether the encoder is in constant contact with the substrate/the conveyor belt and if there is no slip between the encoder wheel and the substrate/the conveyor belt. The actual speed is fluctuating too much. Make sure the substrate is moving at a relative stable speed.</p>

9.5.2 Often seen print results

Correct print result



Fig. 9.40 Print result is correct

Ink starvation

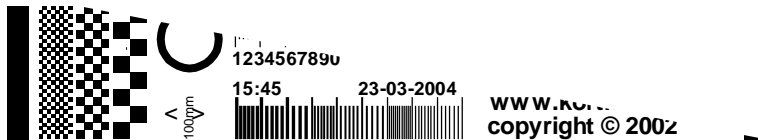

Fig. 9.41 Print result of air bubbles in the ink or reduced ink flow

Remedy: check for low ink level (LED indicators on control unit are on) refill if required and prime the printhead. Refer to subsection 8.5.2.

When several times priming does not improve the print quality, replace the ink filter. This in order to make sure the filter is not clogged/blocking the ink flow. Refer to subsection 10.4.10.

Nozzle blockage and/or air bubbles



Fig. 9.42 Print result when nozzles are clogged with ink/dirt or blocked by air bubbles.

Remedy: clean the nozzle plate and purge or/and prime the printhead. Refer to subsections 8.5.1 and 8.5.2. When not successful, prime the printhead with cleaner.

Vibrations in the ink tube can lead to air bubbles inside the piezo printhead. The coding unit X54 is more sensitive for this effect. For this reason 2 ink tube clamps are included in the package of the X54. These clamps should be used to connect the ink tube to the bracket of the coding unit in order to minimise the vibrations in the ink tube.

Incorrect print length due to wrong speed setting

In this section the correct print speed is defined as the speed at which the horizontal print resolution is equal to the printhead vertical resolution. The printhead vertical resolution is 185 dpi (dots per inch). The product speed must be in range of the print speed (X18, X18si – 40m/min max; X18+, X54 – 60m/min max, X72 – 45m/min max).



Fig. 9.43 Test image printed too fast, length < 100 mm (X72 <175mm)

Remedy: decrease the speed parameter or use an encoder.



Fig. 9.44 Test image printed too slow, length > 100 mm (X72 > 175mm)

Remedy: increase the speed parameter or use an encoder.



Fig. 9.45 Test image printed with variable product speed

The product speed was at period A too slow and at period B too fast. Remedy: avoid product speed variations or use an encoder.

10 MAINTENANCE

The X-series printers are designed specifically for robust operation. Key to ensuring optimal operation and extended life is appropriate maintenance. It is important to inspect the printer visually and check the print quality both on a regular basis.

The periods of maintenance are based on an average factory environment in which the printers are installed. Depending on the actual circumstances the periods of maintenance may vary.

This section covers the routinely maintenance that can be easily performed by the user.

10.1 Quick and regular checks

Inspect the printer visually and check the print quality both on a regular basis.

Daily or weekly maintenance is only necessary when, due to the printing environment, the same problems occur regularly. Do NOT clean the nozzle plate of the printhead if the prints are just fine. Refer to chapter 9 for setting up a custom maintenance plan, to minimize problems.

10.2 Nozzle maintenance

1. Put on protection gloves and use safety goggles for personal protection.
2. Purge the printhead. Refer to subsection 8.5.1. The nozzles will be cleaned of small particles.
3. Spray with the spout of the cleaner bottle some cleaner on the front and nozzle plate. Let the cleaner flow down of the front and nozzle plate, taking with it most of the ink and particles.



CAUTION:

ONLY use GJ cleaner. Do NOT use cotton buds, the micro fibres will obstruct or damage the nozzles of the printhead.

4. Take a clean cloth, if necessary with some cleaner, and gently wipe off all excessive ink and particles from the printhead housing. Take care that the excessive ink and particles are NOT wiped onto the nozzle plate.

10.3 Yearly maintenance

To prevent loss of production it is advisable to service the printer once a year. It is advised that only service engineers, qualified by Korthofah BV, perform the yearly maintenance.

10.4 Replacing parts of the printhead housing

Only service engineers, qualified by Korthofah BV, are allowed to replacing parts of the printer.



CAUTION:

- Always take anti-static precautions when opening the coding unit or the TsC20 controller e.g. to replace electronic components like PCB's .

10.4.1 Anti-static precautions

In order to avoid potential damage to the printhead and printed circuit boards (PCB) please ensure anti-static precautions are observed throughout the installation procedure.

Korthofah cannot be held responsible for damage to the printhead and PCB's caused by mishandling.

Before opening the printhead housing, please adhere to these precautions:

- Ensure that the printer is switched off and disconnected from the mains supply.
- Discharge yourself before handling the equipment (a grounding wrist strap should be used).
- Use an ESD safe workplace to do any repairs or for storing the piëzo head or PCB's.
- Do not touch the front plate of the printhead with bare hands.
- Do not place the equipment on or near materials such as Styrofoam, plastic and vinyl. Keep printhead or PCB's in an anti-static bag used for transporting until ready to fit.

Other useful precautions:

- Residue on the front plate should be removed with cleaner. Do not rub the front plate as there is a change debris will be pushed in the nozzles and/or the front plate can get damaged due to this.
- Use only Kortho GJ ink as this ink is 100% compatible with all materials used in the coding unit.
- The printhead should be free from any condensation to avoid corrosion.

10.4.2 Open the printhead housing

1. Switch off the control unit and disconnect the mains power cable.
2. Put on protection gloves and use safety goggles for personal protection.
3. Protect the host machine surface underneath the printhead housing against contamination with ink.
4. Unscrew the lock screws (6) to release the printhead cover (7).



Fig. 10.1 Removing the printhead cover

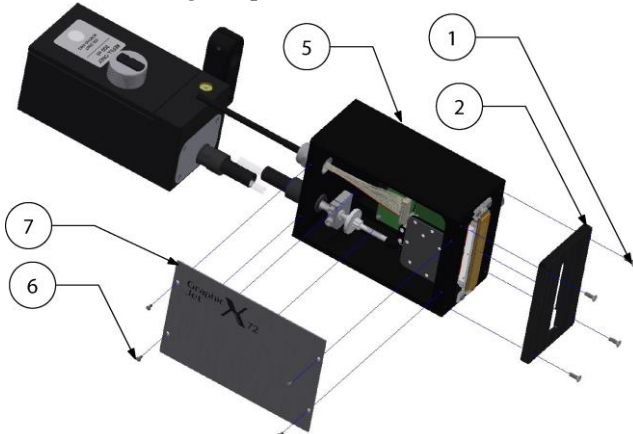

10.4.3 Close the printhead housing

1. Clean, if necessary, the printhead housing (5).
2. Place the printhead cover (7) and place the lock screws (6).
3. Connect the mains power cable and switch on the control unit.

10.4.4 Replacing the printhead PCB [X18, X18si, X18+]



CAUTION:

Always ensure anti-static precautions are observed when handling the Printhead or Printhead PCB (PIB) or it might get damaged, see subsection 10.4.1

1. Open the printhead housing. Refer to subsection 10.4.2.

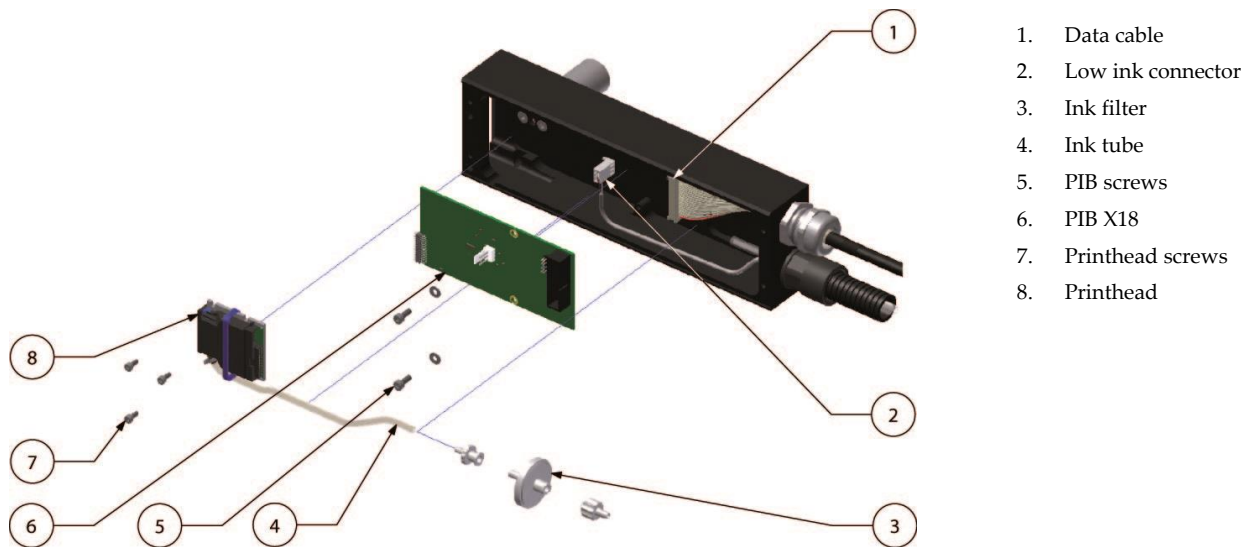

1. Data cable
2. Low ink connector
3. Ink filter
4. Ink tube
5. PIB screws
6. PIB X18
7. Printhead screws
8. Printhead

Fig. 10.2 Replace printhead parts [X18, X18si, X18+]

2. Disconnect the data cable (1) and low ink connector (2) from the PIB.
3. Loosen the two PIB screws (5).
4. Take the PIB (6) out of the printhead housing. Pull the PIB gently but firmly off the printhead connector.
5. Take the new PIB out of the anti-static bag.
6. Push the PIB gently but firmly in the printhead connector. Make sure the PIB is exactly in line with the printhead and aligned with the printhead connector.
7. Fasten the PIB screws.
8. Connect the data cable and low ink connector to the PIB.
9. Close the printhead housing. Refer to subsection 10.4.3.
10. Prime excessive air from the system.
11. The printer is now ready to print.

10.4.5 Replacing the printhead PCB [X54]



CAUTION:

Always ensure anti-static precautions are observed when handling the Printhead or Printhead PCB (PIB) or it might get damaged, see subsection 10.4.1

1. Open the printhead housing. Refer to subsection 10.4.2.

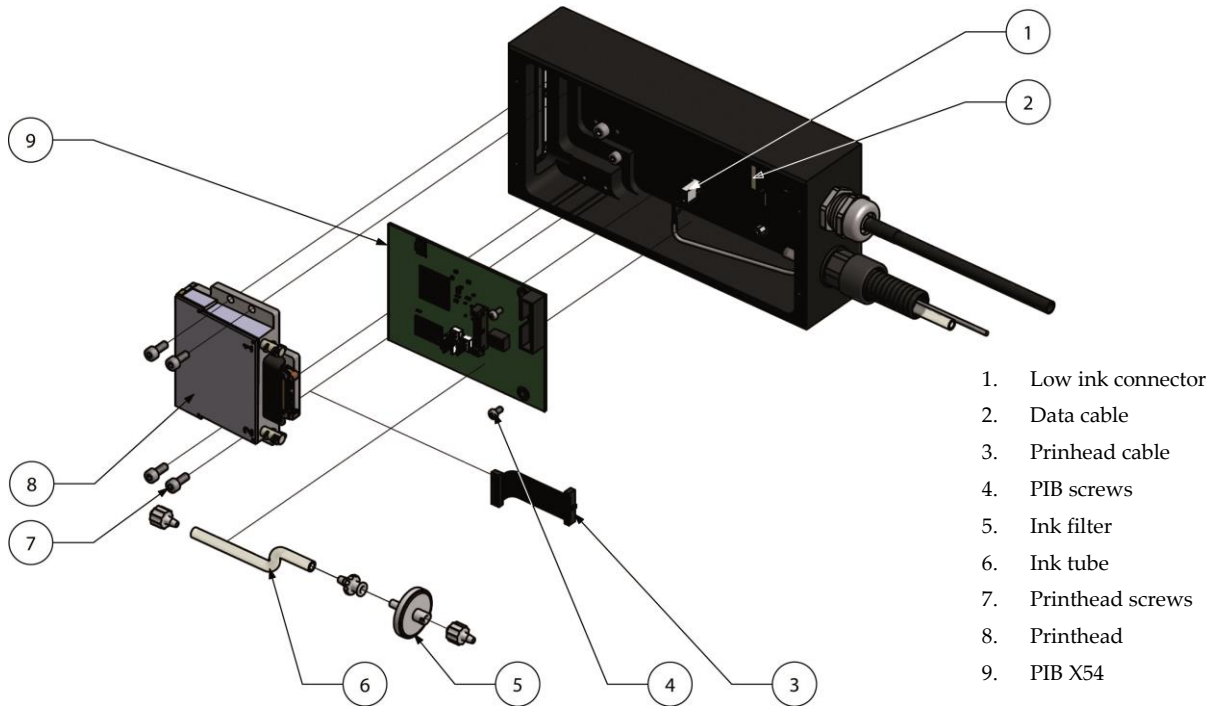

1. Low ink connector
2. Data cable
3. Printhead cable
4. PIB screws
5. Ink filter
6. Ink tube
7. Printhead screws
8. Printhead
9. PIB X54

Fig. 10.3 Replace printhead parts [X54]

2. Disconnect the low ink connector (2), the data cable (1) and the printhead cable (3) from the PIB.
3. Loosen the two PIB screws (4).
4. Take the PIB (9) out of the printhead housing.
5. Take the new PIB out of the anti-static bag.
6. Place the PIB and fasten the PIB screws.
7. Connect the low ink connector, the data cable and the printhead cable to the PIB.
8. Close the printhead housing. Refer to subsection 10.4.3.
9. Prime excessive air from the system.
10. The printer is now ready to print.

10.4.6 Replacing the printhead PCB [X72]



CAUTION:

Always ensure anti-static precautions are observed when handling the Printhead or Printhead PCB (PIB) or it might get damaged, see subsection 10.4.1

1. Open the printhead housing by unscrewing the screws of the lid. Refer to subsection 10.4.2.

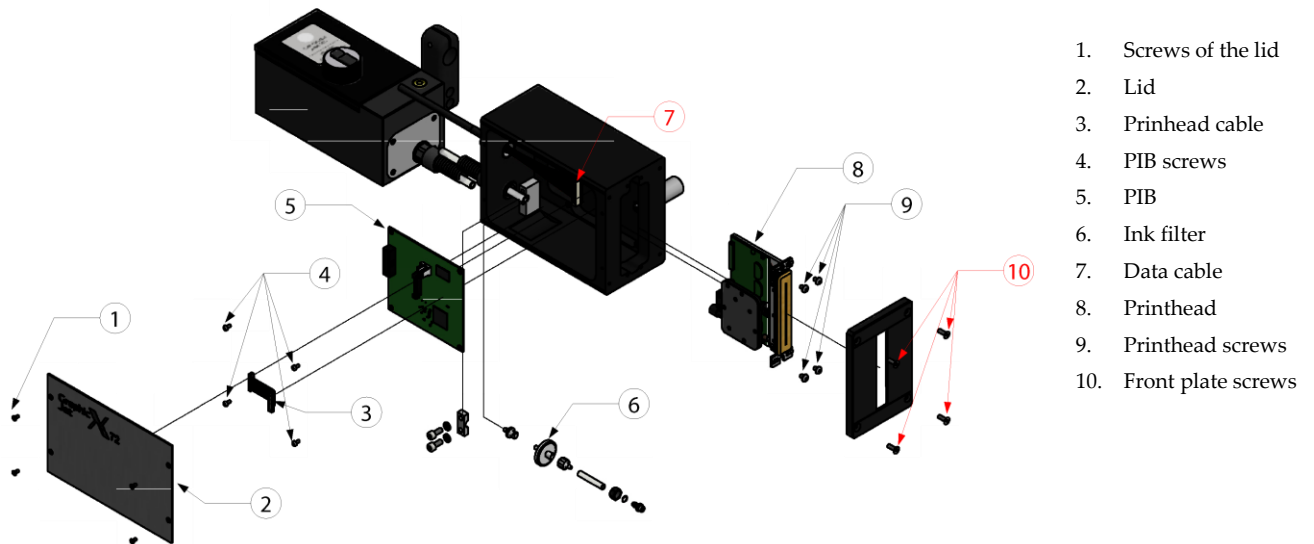

1. Screws of the lid
2. Lid
3. Printhead cable
4. PIB screws
5. PIB
6. Ink filter
7. Data cable
8. Printhead
9. Printhead screws
10. Front plate screws

Fig. 10.4 Replace printhead parts [X72]

2. Disconnect the low ink connector (not shown), the data cable (7) and the printhead cable (3) from the PIB.
3. Unscrew the front plate screws (10) and remove the front plate
4. Unscrew the ink tube from the ink filter. Leave the filter in place. Be aware, ink will come out!
5. Unscrew the printhead screws (9)
6. The printhead is now completely loose. Take it out of the housing and store in a safe location,
7. Unscrew the four screws that hold the PIB (4).
8. Take the PIB out of the printhead housing.
9. Take the new PIB and place it in the printhead housing.
10. Place the four PIB screws and connect the data cable and low ink cable
11. Take the printhead and slide it back into position
12. Screw back the four printhead screws. However, leave left bottom and top right untightened and loosely tighten the others.
13. Take the front plate and ever so carefully fit it over the printhead and see if it aligns properly with the printhead housing. Due to the two loosely tightened printhead screws, the head can be gently pushed in the proper position. Be careful!!
14. When the printhead is in position, take off the front plate and tighten the printhead screws.
15. Place the front plate and front plate screws and tighten them
16. Connect the printhead cable to the PIB. Be careful, the FCC cable can easily damage.
17. Connect the ink tube on the filter. Make sure it is tightened properly.
18. Prime the head to make sure all air is out of the ink tubing and printhead
19. Place the lid and the screw the four screws back in.

10.4.7 Replacing the piezo printhead [X18, X18si, X18+]

**CAUTION:**

Read Printhead safety notes before handling the printhead, see subsection 10.4.1. Always ensure anti-static precautions are observed when handling a printhead or it might be damaged.

Replacing the printhead means that also the ink tube connected to the printhead and the filter must be replaced. The ink tube is deformed when it is connected to the printhead fitting. Re-use of the ink tube increases the risk of ink leakage.

It is advised also to replace the inkfilter when replacing the printhead.

1. Open the printhead housing. Refer to subsection 10.4.2.
2. Disconnect the data cable (1 in Fig. 10.2) and low ink connector (2 in Fig. 10.2) from the PIB.
3. Loosen the three printhead screws (7 in Fig. 10.2).
4. Loosen the two PIB screws (5 in Fig. 10.2).
5. Take the printhead (8 in Fig. 10.2) and PIB (6 in Fig. 10.2) out of the printhead housing.
6. Pull the PIB gently but firmly off the printhead connector.
7. Disconnect the ink filter (3 in Fig. 10.2) by turning the couplings anti-clockwise.
8. Connect the new ink filter.
9. Take the new printhead out of the anti-static bag.
10. Cut down the new ink tube to the proper length, use the old ink tube as a reference.
11. Place the luer lock connector on the ink tube.
12. Push the PIB gently but firmly in the printhead connector. Make sure the PIB is exactly in line with the printhead and aligned with the printhead connector.
13. Remove the nozzle protection cover. Do not touch the nozzle plate!
14. Place the printhead and PIB in position, place the printhead and PIB screws but do not tighten them.
15. Press the printhead firmly against the frontplate gasket and fasten the printhead screws.
16. Fasten the PIB screws.
17. Connect the new ink tube to the ink filter. Twist the filter tube before connecting the new ink tube, so there is no tension on the connection and tubing after the new ink tube is connected.
18. Connect the data cable and low ink connector to the PIB.
19. Close the printhead housing. Refer to subsection 10.4.3.
20. Prime excessive air from the system.
21. The printer is now ready to print.

10.4.8 Replacing the piezo printhead [X54]

**CAUTION:**

Read Printhead safety notes before handling the printhead, see subsection 10.4.1. Always ensure anti-static precautions are observed when handling a printhead or it might be damaged.

It is advice also to replace the ink filter when replacing the printhead.

1. Open the printhead housing. Refer to subsection 10.4.2.
2. Disconnect the printhead cable (3 in Fig. 10.3) from the PIB.
3. Loosen the three printhead screws (7 in Fig. 10.3).
4. Take the printhead (8 in Fig. 10.3) out of the printhead housing.

5. Disconnect the ink tubes (6 in Fig. 10.3) from the printhead and ink filter by turning the couplings anti-clockwise.
6. Connect the new ink filter.
7. Take the new printhead out of the anti-static bag.
8. Remove the nozzle protection cover. Do not touch the nozzle plate!
9. Place the printhead in position, place the printhead screws but do not tighten them.
10. Press the printhead firmly against the front plate gasket and fasten the printhead screws.
11. Connect the ink tube to the printhead. Twist the filter tube before connecting the ink tube, so there is no tension on the connection and tubing after the new ink tube is connected.
12. Close the printhead housing. Refer to subsection 10.4.3.
13. Prime excessive air from the system.
14. The printer is now ready to print.

10.4.9 Replacing the piezo printhead [X72]

**CAUTION:**

Read Printhead safety notes before handling the printhead, see subsection 10.4.1. Always ensure anti-static precautions are observed when handling a printhead or it might be damaged.

It is advice also to replace the ink filter when replacing the printhead.

1. Open the printhead housing. Refer to subsection 10.4.2 and 10.4.6.
2. Disconnect the printhead cable (3) from the PIB.
3. Unscrew the front plate screws (10) and remove the front plate.
4. Unscrew the ink tube from the printhead. Be aware, ink will come out!
5. Unscrew the printhead screws (9)
6. The printhead is now completely loose. Take it out of the housing and pull out the printhead cable. Store the printhead in a safe location.
7. Take the new printhead and gently push the printhead cable in the printhead connector.
8. Put the new printhead back in the printhead housing, making sure the printhead cable is going in first.
9. Screw back the four printhead screws. However, leave left bottom and top right untightened and loosely tighten the others.
10. Take the front plate and ever so carefully fit it over the printhead and see if it aligns properly with the printhead housing. Due to the two loosely tightened printhead screws, the head can be gently pushed in the proper position. Be careful!!
11. When the printhead is in position, take off the front plate and tighten the printhead screws.
12. Place the front plate and front plate screws and tighten them
13. Reconnect the ink tube to the printhead.
14. Prime excessive air from the system.
15. Close the printhead housing. Refer to subsection 10.4.3. and 10.4.6

10.4.10 Replacing the ink filter

1. Open the printhead housing. Refer to subsection 10.4.2.
2. Disconnect the ink filter from the printhead ink tube by turning the couplings anti-clockwise.
3. Disconnect the ink filter from the ink supply tube by turning the filter anti-clockwise.
4. Place the new filter by performing instructions 3 and 2 in reverse direction. While performing step 2, twist the ink tube before connecting the filter to the printhead ink tube, so there is no tension on the connection and tubing after the new ink tube is connected.
5. Wipe the printhead frame clean in case of spilled ink.
6. Close the printhead housing. Refer to subsection 10.4.3.
7. Prime excessive air from the system, refer to subsection 10.4.4.
8. The printer is now ready to print.

10.5 Updating firmware and software

The firmware and software can be updated, see paragraph 9.2.6.

11 DISMANTLING & DISPOSAL

At the end of the technical lifetime of the system it should be dismantled and disposed according to local regulations. The general guide line to do so is described.

11.1 Dismantling

Dismantle the printer only in a well-ventilated area.

Wear safety goggles, suitable protective clothing, face shield and chemical resistant gloves made of polyvinyl alcohol (PVA), PTFE (Teflon) or the ones supplied by Korthofah.

Separate the printer parts in this order:

11.1.1 System

1. Switch off the system.
2. Unplug the mains power cable.
3. Disconnect all remaining connections from the control unit.
4. Dismount the supports.
5. Separate the supports from the coding unit and the control unit.

11.1.2 Ink reservoir

1. Open the reservoir screw cap.
2. Pour the remaining ink in a waste container.
3. Let the ink reservoir drain dry.
4. Treat the waste container and its contents as special waste.

11.1.3 Printhead housing

1. Open the printhead housing.
2. Remove the printed circuit board.
3. Remove the printhead.
4. Treat the printed circuit board and the printhead as electronic waste.

11.1.4 Control unit

1. Open the control unit.
2. Remove the printed circuit boards.
3. Remove the touch panel.
4. Remove the net-entree and wire looms.
5. Remove the power supplies.
6. Treat the printed circuit boards, the touch screen, the net-entree and the power supplies as electronic waste.

11.1.5 Sensor devices

1. Treat the photocell as electronic waste.
2. Treat the encoder as electronic waste.

11.1.6 Ink and cleaner

1. Treat the ink and cleaner as mentioned in the most recent SDS, which can be obtained at Korthofah BV.

11.2 Disposal

11.2.1 Disposal method

The disposal method must be in accordance with national and local regulations at the time of the disposal.

The user is responsible for the disposal of:

1. The printer at the end of its operational life.
2. Wasted ink and unused ink at the end of the printer's operational life, see most recent SDS.
3. Wasted cleaner and unused cleaner at the end of the printer's operational life, see most recent SDS.
4. Containers, clothing cleaning foam swabs and paper wipers contaminated with ink and/or cleaner.
5. Packaging.

11.2.2 Waste separation

Please deliver the packaging materials to waste recycling companies.

Printed circuit boards, power supplies, touch panel, power entry module, encoders and wire looms are considered electronic waste, because poisons found in electronic waste include lead, mercury, cadmium, and brominated flame-retardants commonly added to plastics used in electronics. As the system is RoHS compliant the amount of hazardous materials mentioned above will be limited.

The remaining materials consist mainly of anodized aluminium and stainless steel.

Empty ink or cleaner containers, paper wipers and clothing contaminated with ink and/or cleaner can count as special waste.

The ink and cleaner should be treated separately according to the method as mentioned in the most recent SDS.

The remaining materials must also be delivered to waste recycling companies.

Index

■ Keywords

A

anti-static 10-2, 10-3, 10-4, 10-5, 10-6

B

bitmap 1-5, 3-1, 9-3

bracket 1-2, 6-3, 6-5, 6-14, 9-25, 9-28

C

coding unit 1-2, 1-3, 1-4, 1-5, 2-1, 3-3, 4-1, 4-2, 4-4, 5-1, 5-2, 5-3, 6-2, 6-3, 6-5, 6-6, 6-11, 6-14, 7-1, 7-2, 7-6, 7-9, 7-10, 7-12, 8-1, 8-14, 8-16, 8-19, 8-29, 8-31, 8-39, 9-9, 9-21, 9-23, 9-24, 9-24, 9-25, 9-26, 9-27, 9-28, 10-2, 11-1

control panel 4-4

control unit 1-1, 1-3, 1-4, 1-5, 2-1, 2-6, 3-1, 3-2, 3-3, 3-8, 4-1, 4-2, 4-3, 6-3, 6-13, 6-14, 7-1, 7-2, 7-4, 7-5, 7-6, 7-9, 8-1, 8-10, 8-11, 8-14, 8-29, 9-8, 9-9, 9-10, 9-15, 9-18, 9-22, 9-23, 9-25, 9-27, 10-2, 10-3, 11-1

D

debounce 7-10, 8-38

E

electrostatic 1-5, 4-3

F

filling 7-2, 7-4, 8-15, 8-16

firmware 3-8, 9-9, 9-21, 10-6

first aid 4-4

funcție

knop 8-36, 8-37

function 1-4, 3-2, 7-7, 7-10, 7-11, 8-1, 8-8, 8-9, 8-10, 8-11, 8-15, 8-25, 8-28, 8-38, 9-2, 9-4, 9-6, 9-12, 9-13, 9-16, 9-18, 9-20

button 3-3, 3-4, 3-5, 3-6, 3-7, 7-5, 7-6, 7-7, 7-8, 7-9, 7-10, 7-11, 8-1, 8-2, 8-5, 8-6, 8-7, 8-9, 8-10, 8-11, 8-17, 8-18, 8-20, 8-21, 8-22, 8-23, 8-25, 8-28, 8-32, 8-35, 8-37, 8-38, 9-1, 9-2, 9-3, 9-4, 9-5, 9-7, 9-8, 9-9, 9-10, 9-11, 9-12, 9-13, 9-14, 9-15, 9-16, 9-18, 9-19, 9-20, 9-21

H

handling 4-3, 5-1, 5-3, 10-2, 10-3, 10-4, 10-5

host 1-1, 1-4, 4-2, 6-1, 6-14, 7-7, 7-8, 7-9, 8-31, 9-11, 9-12, 10-2

humidity 1-2, 1-4, 7-11

I

image 3-1, 8-38, 9-9, 9-18, 9-28

indicator 3-3, 4-4, 7-2, 7-7, 8-1, 8-16, 9-23, 9-25

ink 1-1, 1-2, 1-4, 2-3, 3-1, 3-2, 3-3, 4-1, 4-4, 5-1, 5-2, 5-3, 5-4, 6-2, 6-4, 6-5, 6-6, 6-7, 6-11, 6-12, 7-2, 7-3, 7-4, 7-5, 7-10, 7-11, 7-12, 8-14, 8-15, 8-16, 8-17, 8-18, 8-19, 8-26, 8-30, 8-31, 8-38, 8-39, 9-7, 9-11, 9-12, 9-23, 9-24, 9-24, 9-25, 9-26, 9-27, 9-28, 10-1, 10-2, 10-3, 10-4, 10-5, 10-6, 11-1

filter 2-3, 5-3, 9-24, 9-24, 9-26, 9-27, 10-5, 10-6

reservoir 3-2, 4-4, 5-1, 5-2, 5-3, 6-4, 6-5, 6-6, 6-7, 6-11, 6-12, 7-2, 7-3, 7-4, 7-12, 8-15, 8-16, 8-17, 8-18, 8-19, 8-26, 9-24, 9-24, 9-25, 9-26, 9-27, 11-1

interface 1-4, 3-2, 3-3, 4-2, 6-1, 6-14, 9-9, 9-18, 9-22, 9-23, 9-25

M

maintenance 1-1, 1-2, 1-5, 4-1, 5-2, 5-3, 6-4, 10-1, 10-2

memory 1-5, 3-1, 7-12, 8-8

INDEX

label	1-5, 8-5, 8-6, 8-10, 9-23
print	1-1, 1-5, 8-5, 8-7
menu structure	3-2, 3-9
N	
nozzle	2-3, 3-2, 4-4, 5-2, 5-3, 6-11, 6-12, 7-5, 7-10, 8-14, 8-17, 8-18, 8-19, 8-38, 9-7, 9-24, 9-25, 9-26, 9-27, 9-28, 10-1, 10-2, 10-5, 10-6
O	
operator	1-1, 1-5, 3-2, 6-14, 8-2, 8-3, 8-4, 8-5, 8-6, 8-12, 8-22
orientation	3-2, 6-5, 6-11, 8-35
P	
parameter	3-1, 6-12, 7-7, 7-8, 7-9, 7-10, 8-1, 8-29, 9-28
date	1-1, 1-4, 1-5, 2-1, 3-1, 8-4, 8-12, 8-21, 8-23, 9-1, 9-9, 9-15
delay	6-12
direction	7-8, 9-24
language	3-4, 8-21, 8-22
rotation	7-9
speed	1-2, 2-1, 2-5, 3-1, 6-3, 6-13, 7-5, 7-6, 7-7, 7-8, 8-29, 8-38, 9-7, 9-9, 9-11, 9-15, 9-24, 9-26, 9-27, 9-28
stretch	8-36
time	1-1, 1-4, 1-5, 2-1, 3-1, 5-1, 5-2, 7-1, 7-2, 7-5, 7-7, 7-10, 7-11, 8-4, 8-13, 8-19, 8-21, 8-26, 8-38, 8-39, 9-16
power supply	1-3, 4-1, 4-2, 4-3, 9-8, 9-22
precautions	4-3, 6-4, 6-12, 6-13, 10-2, 10-3, 10-4, 10-5
prime	5-1, 5-2, 5-3, 7-5, 8-18, 8-19, 9-27, 9-28
bulb	7-5, 8-18, 8-19
print	
cycle	3-1, 6-1, 7-9, 7-11
test	1-4, 7-5, 7-7, 7-8, 7-9, 9-6
printhead	1-4, 1-5, 2-1, 2-3, 3-1, 3-2, 3-3, 4-1, 4-2, 4-3, 4-4, 5-1, 5-2, 5-3, 6-2, 6-4, 6-5, 6-6, 6-7, 6-9, 6-11, 6-12, 6-13, 7-2, 7-5, 7-6, 7-7, 7-8, 7-10, 7-11, 7-12, 8-17, 8-18, 8-19, 8-26, 8-38, 9-7, 9-8, 9-10, 9-24, 9-24, 9-25, 9-26, 9-27, 9-28, 10-1, 10-2, 10-3, 10-4, 10-5, 10-6, 11-1
piezo	3-1, 8-17, 9-7, 9-28, 10-5
product	2-1, 2-5, 3-1, 4-1, 5-3, 6-4, 6-6, 6-11, 6-12, 6-13, 7-7, 7-8, 7-11, 9-23, 9-24, 9-25, 9-28
protection	1-1, 4-3, 4-4, 6-4, 7-2, 8-16, 8-17, 8-18, 10-1, 10-2, 10-5, 10-6
purge	1-4, 8-17, 8-18, 9-28
Q	
qualified	1-1, 9-10, 9-22, 10-2
R	
rotation	6-6, 6-7, 6-9, 6-11
S	
safety	1-1, 4-4, 7-2, 8-16, 8-17, 8-18, 10-1, 10-2, 10-5, 11-1
sensor	7-10, 8-28, 9-8, 9-11, 9-23, 9-24, 9-25
encoder	2-1, 2-5, 3-1, 4-2, 6-3, 6-13, 6-14, 7-6, 7-7, 7-8, 8-29, 8-38, 9-9, 9-11, 9-24, 9-25, 9-26, 9-27, 9-28
photocell	2-1, 2-5, 3-1, 4-2, 6-1, 6-12, 6-13, 6-14, 7-7, 7-8, 7-9, 7-10, 9-23, 9-25
solvent	1-1, 1-2, 1-4, 2-3, 4-4, 5-2, 5-3, 5-4, 6-4, 7-10, 9-24, 9-25, 9-26, 9-27, 9-28, 10-1, 10-2
storage	1-5, 5-2, 5-3
substrate	1-4, 1-5, 2-1, 2-5, 3-1, 6-6, 6-11, 6-13, 7-7, 7-10, 8-26, 8-29, 8-31, 8-38, 9-23, 9-24, 9-25, 9-26, 9-27
symbol	
caution	4-4
note	2-6, 6-1, 7-9, 8-1, 8-2, 8-4, 8-7, 8-10, 8-11, 8-15, 8-21, 8-29, 9-3, 9-4, 9-5, 9-10, 9-13, 9-20

T

temperature	1-2, 1-4, 5-3, 7-11, 9-8
touch screen	3-3, 11-1
transport	5-1, 5-4
trigger	3-1, 6-12, 7-9, 8-29
request	2-1, 3-1, 4-2, 6-1, 6-12, 6-14, 7-9, 7-10, 8-1, 8-2, 8-22, 8-38, 9-24, 9-24, 9-25

V

voltage	3-1, 4-2, 9-8, 9-10, 9-22
---------	---------------------------

W

waste	3-2, 5-2, 5-3, 8-19, 11-1
-------	---------------------------

■ **Figures**

Fig. 1.1	Coding units, global dimensions	1-2
Fig. 1.2	Control unit, global dimensions	1-3
Fig. 2.1	The printer system	2-1
Fig. 2.2	Coding unit, parts	2-2
Fig. 2.3	Ink reservoir, parts	2-2
Fig. 2.4	Printhead housing & bracket parts	2-2
Fig. 2.5	Printhead interior, parts	2-3
Fig. 2.6	Control unit	2-3
Fig. 2.7	Control unit, connections	2-4
Fig. 2.8	Photocell	2-5
Fig. 2.9	Encoder	2-5
Fig. 3.1	Piezo printhead technology	3-1
Fig. 3.2	Printhead and ink levels	3-2
Fig. 3.3	Screen layout	3-3
Fig. 3.4	First keyboard screen	3-4
Fig. 3.5	Arabic keyboard	3-4
Fig. 3.6	First keyboard screen, alternative alphanumerics	3-5
Fig. 3.7	Second keyboard screen, numeric and special characters	3-5
Fig. 3.8	Third keyboard screen, commonly used text	3-6
Fig. 3.9	Programming third keyboard screen buttons, entering text	3-6
Fig. 3.10	Programming third keyboard screen buttons, entering text	3-7
Fig. 3.11	Fourth keyboard screen, edit text and use cursor controls	3-7
Fig. 3.12	Numeric keyboard	3-8
Fig. 3.13	Entering the System information screen	3-8
Fig. 3.14	Standard menu structure	3-9
Fig. 4.1	Control unit identification label	4-1
Fig. 4.2	Power supply information	4-2
Fig. 4.3	Attention label for opening control unit	4-3
Fig. 4.4	Ink reservoir label, ink type GJ8 and GJ9 (as example)	4-4
Fig. 5.1	Shipping and handling labels	5-1
Fig. 6.1	Typical printer application	6-2
Fig. 6.2	Coding units X-series	6-2
Fig. 6.3	Control unit TsC20	6-3
Fig. 6.4	Encoder with support	6-3
Fig. 6.5	Distance between front plate and product	6-4
Fig. 6.6	Ink reservoir mounting clamp heights	6-5
Fig. 6.7	Parallel reservoir	6-5
Fig. 6.8	Perpendicular reservoir	6-5
Fig. 6.9	Printhead clamp mounting options	6-6
Fig. 6.10	Printhead radial rotation 0°, standard support, clamp down, reservoir position I	6-7
Fig. 6.11	Printhead radial rotation 45°, standard support, clamp down, reservoir position III	6-7
Fig. 6.12	Printhead radial rotation 90°, standard support, clamp down, reservoir position II	6-8
Fig. 6.13	Printhead radial rotation graph	6-8
Fig. 6.14	Printhead axial rotation 0°, 45° and 90°, clamp down, reservoir position I, $x_{gap} = 10mm$	6-9

Fig. 6.15	Printhead axial rotation -45°, clamp up, reservoir position III, $x_{gap} = 18mm$	6-10
Fig. 6.16	Printhead axial rotation graph	6-10
Fig. 6.17	Photocell positions (front view)	6-12
Fig. 6.18	Photocell distance to the product (top view).....	6-12
Fig. 6.19	Encoder adjustment.....	6-13
Fig. 7.1	Main menu	7-1
Fig. 7.2	Printer settings menu.....	7-1
Fig. 7.3	Printhead housing at horizontal position.....	7-2
Fig. 7.4	Cut ink bottle open	7-3
Fig. 7.5	Ink reservoir opened	7-3
Fig. 7.6	Ink reservoir with ink bottle placed.....	7-4
Fig. 7.7	Ink reservoir with prime bulb	7-5
Fig. 7.8	Settings menu	7-6
Fig. 7.9	Diagnostics – Test label menu.....	7-6
Fig. 7.10	Diagnostics – Test menu.....	7-7
Fig. 7.11	Test label printed at correct speed setting (X18)	7-8
Fig. 7.12	Test label printed	7-8
Fig. 7.13	Test label printed mirrored	7-9
Fig. 7.14	Test label printed upside-down	7-9
Fig. 7.15	Settings - Print menu	7-11
Fig. 7.16	Printer parameters, default and user values	7-13
Fig. 7.17	Printer information.....	7-13
Fig. 8.1	Main menu	8-1
Fig. 8.2	Main menu – Status bar	8-2
Fig. 8.3	Text item input menu	8-3
Fig. 8.4	Date advance input menu	8-4
Fig. 8.5	Number start value input menu.....	8-5
Fig. 8.6	Select label menu	8-6
Fig. 8.7	Copy label menu, USB thumbdrive	8-7
Fig. 8.8	Copy label menu, label memory	8-7
Fig. 8.9	Overwriting label message.....	8-8
Fig. 8.10	Move label menu	8-8
Fig. 8.11	Paste label menu	8-9
Fig. 8.12	Delete label menu.....	8-9
Fig. 8.13	Delete label message.....	8-10
Fig. 8.14	Select a label for editing	8-10
Fig. 8.15	Edit a label.....	8-11
Fig. 8.16	Create label screen.....	8-12
Fig. 8.17	Ink calculator screen.....	8-14
Fig. 8.18	Preview screen 1:8 and 1:1.....	8-15
Fig. 8.19	Cut ink bottle open	8-16
Fig. 8.20	Ink reservoir opened	8-16
Fig. 8.21	Ink reservoir with ink bottle placed.....	8-17
Fig. 8.22	Purging	8-18
Fig. 8.23	Printhead housing at horizontal position.....	8-18
Fig. 8.24	Ink reservoir with prime bulb attached	8-19
Fig. 8.25	Settings menu	8-20
Fig. 8.26	System settings menu	8-20
Fig. 8.27	Setting the time	8-20
Fig. 8.28	Setting the date	8-21
Fig. 8.29	System language selection menu.....	8-21
Fig. 8.30	Date Language selection menu	8-22
Fig. 8.31	Rollover hour selection menu	8-23
Fig. 8.32	Messages when activating / deactivating of the BCD mode	8-23
Fig. 8.33	Menu Schermbeveiliging.....	8-25
Fig. 8.34	System settings menu	8-25
Fig. 8.35	Signal settings menu	8-28
Fig. 8.36	Signal settings outputs and inputs	8-30
Fig. 8.37	Network settings menu.....	8-32
Fig. 8.38	Network settings, IP address	8-33
Fig. 8.39	Network settings, UDP Port	Fout! Bladwijzer niet gedefinieerd.
Fig. 8.40	Network settings, Automation IP address	8-34
Fig. 8.41	Network settings, Automation Port	8-34

INDEX

Fig. 8.42	Label settings menu	8-35
Fig. 8.43	Orientation setting selection	8-35
Fig. 8.44	Orientation setting	8-35
Fig. 8.45	Label Settings; Add BCD Code	8-36
Fig. 8.46	Label settings; Load BCD list	8-37
Fig. 8.47	Print settings menu	8-37
Fig. 9.1	Service menu	9-1
Fig. 9.2	Test label menu	9-1
Fig. 9.3	Test label loaded	9-2
Fig. 9.4	Font menu	9-2
Fig. 9.5	List fonts menu	9-3
Fig. 9.6	Delete fonts menu	9-3
Fig. 9.7	Delete files(s), are you sure?	9-4
Fig. 9.8	Add fonts menu	9-5
Fig. 9.9	File copy successful	9-5
Fig. 9.10	Preview font menu	9-6
Fig. 9.11	Test menu	9-6
Fig. 9.12	Service - Printer menu	9-8
Fig. 9.13	Printer diagnostics screen	9-8
Fig. 9.14	Software and firmware version screen	9-9
Fig. 9.15	System information screen	9-9
Fig. 9.16	Error-Warning list	9-10
Fig. 9.17	Diagnostics menu	9-11
Fig. 9.18	IO feedback screen	9-11
Fig. 9.19	Graphics menu	9-12
Fig. 9.20	Graphic preview	9-12
Fig. 9.21	Delete graphics menu	9-13
Fig. 9.22	Delete graphic, are you sure?	9-13
Fig. 9.23	Add graphics menu	9-14
Fig. 9.24	Information menu	9-15
Fig. 9.25	General information screen	9-15
Fig. 9.26	Health screen	9-16
Fig. 9.27	Enter Backup name	9-16
Fig. 9.28	Backup overwrite	9-17
Fig. 9.29	Backup in progress	9-17
Fig. 9.30	Backup finished	9-18
Fig. 9.31	System information screen	9-18
Fig. 9.32	Enter report name	9-19
Fig. 9.33	Report overwrite	9-20
Fig. 9.34	Creating report in progress	9-20
Fig. 9.35	Report saved	9-20
Fig. 9.36	Upgrade files detected screen	9-21
Fig. 9.37	Upgrade in progress screen	9-22
Fig. 9.38	Upgrade finished screen	9-22
Fig. 9.39	Error/warning message	9-27
Fig. 9.40	Print result is correct	9-29
Fig. 9.41	Print result of air bubbles in the ink or reduced ink flow	9-29
Fig. 9.42	Print result when nozzles are clogged with ink/dirt or blocked by air bubbles.	9-29
Fig. 9.43	Test image printed too fast, length < 100 mm (X72 <175mm)	9-29
Fig. 9.44	Test image printed too slow, length > 100 mm (X72 > 175mm)	9-30
Fig. 9.45	Test image printed with variable product speed	9-30
Fig. 10.1	Removing the printhead cover	10-2
Fig. 10.2	Replace printhead parts [X18, X18si, X18+]	10-3
Fig. 10.3	Replace printhead parts [X54]	10-4
Fig. 10.4	Replace printhead parts [X72]	10-5

Appendix A Specifications

Coding Units X18, X18+ and X18si

Dimensions (including bracket)

Height	322 mm
Width	170 mm
Depth	477 mm

Weight	2,45 kg
---------------	---------

Print area

Height	17,5mm
Length	500mm

Print speed

X18	0 – 40 m/min
X18+	0 – 60 m/min
X18si	0 – 40 m/min

Print head	185 dpi
-------------------	---------

Environment

Temperature	5 °C – 38 °C
Relative humidity	10% – 90% (non-condensing)

Coding Unit X54

Dimensions (including bracket)

Height	322 mm
Width	183 mm
Depth	480 mm

Weight	3,35 kg
---------------	---------

Print area

Height	53,7mm
Length	500mm

Print speed	0 – 60 m/min
--------------------	--------------

Print head	180 dpi
-------------------	---------

Environment

Temperature	5 °C – 38 °C
Relative humidity	10% – 90% (non-condensing)

Coding Unit X72

Dimensions (including bracket)

Height	322 mm
Width	190 mm
Depth	480 mm

Weight	5,2kg
--------	-------

Print area

Height	71,8mm
Length	2000mm

Print speed	0 – 45 m/min
-------------	--------------

Print head	180 dpi
------------	---------

Environment

Temperature	5 °C – 38 °C
Relative humidity	10% – 90% (non-condensing)

Control unit TsC20-X and TsC20-X duo

Dimensions

Height	203 mm
Width	258 mm
Depth	153 mm

Weight	2,8 kg
--------	--------

Power supply

Input voltage	100-240VAC
Frequency	50 – 60 Hz
Power	85VA

Environment

Temperature	5 °C – 38 °C
Relative humidity	10% – 90% (non-condensing)
Interface	USB port Ethernet connection Optically isolated inputs: print request, inhibit, trigger, 2 spare inputs (undefined) Optically isolated outputs: general alarm, busy, low ink, ink out, ready, 1 spare (undefined) outputs

Ink and cleaner

Operational

Temperature (recommended)	5 °C – 38°C (10 °C -30 °C)
---------------------------	----------------------------

Transport and storage

Temperature	10°C - 30 °C
Precautions	store in original packaging away from direct sunlight

Shelf life 12 months

Label features

Label

- Name: User defined name.
- Test label: A label that is permanently available (cannot be deleted) and specifically designed for making test prints to check the print quality and the correct setting of several parameters.
- Items: Text, multiple line text, number, date, time, shiftcode, barcode, line, circle/oval and box items and graphics. These items are placed in a label using label design software or the on-board label design function.
- Data: Fixed and variable.
- Max. items: 25 number items per label (per coding unit). 200 characters per text item when using the on-board label editor. When designed with label design software the limit depends on the software used and is limited to a maximum of 2000 characters by the print engine.

Font:

- General: Full Windows TTF font support. The following fonts are pre-installed in the printer: Arial, **Arial Black**, Arial Narrow, **Century Gothic**, Courier New, Georgia, **Liberations Sans**, **Liberations Serif**, Lucida Sans Unicode, Microsoft Sans Serif, Segoe UI, Segoe UI licht, Segoe UI Semi bold, Tahoma, Times New Roman, Trebuchet MS, Verdana.
- Windows driver: The fonts that are marked in bold are also implemented in the Windows driver. When using the driver these fonts can be used to print fixed and variable text e.g. time, date, operator input text. When another font is used in an item, the driver will convert the item into a bitmap.
- Controller: The fonts used in a label also need to be installed on the control unit. When a font is used in a label which is not installed on the controller, the controller will select an alternative font which is installed on the controller. This will affect the layout of the label. When using the Bold option for text items, install the bold font if possible. If not, Windows will bolderize the selected font, which makes it slower.

Barcode formats: Internal barcode generator, which supports all commonly used barcodes among which Codabar, Code 2 of 5, Code128, Data Matrix, GS1-128, EAN13, EAN8, RSS-14, UPC A.

Items:

- Graphic: Depending on the label design program. Generally in jpg, png or bmp format (black/white).
- Dynamic: Number, date, time and shiftcode.
- Operator input: Text, start value of a counter/number, offset of a date.

Label download: Through Ethernet or a USB thumbdrive.

Storage capacity: 40MB (approximately 400 labels). This memory can be used for storage of:

- a. Labels
- b. Graphics
- c. Fonts

Appendix B Dimensions

Coding unit X18, X18*+ and X18si and Bracket B-2

Coding unit X54 and Bracket..... B-3

Coding unit X72 and Bracket..... B-3

Control unit..... B-4

Control unit and Bracket B-6

Coding unit X18, X18*+ and X18si and Bracket

Dimensions are metric [mm]

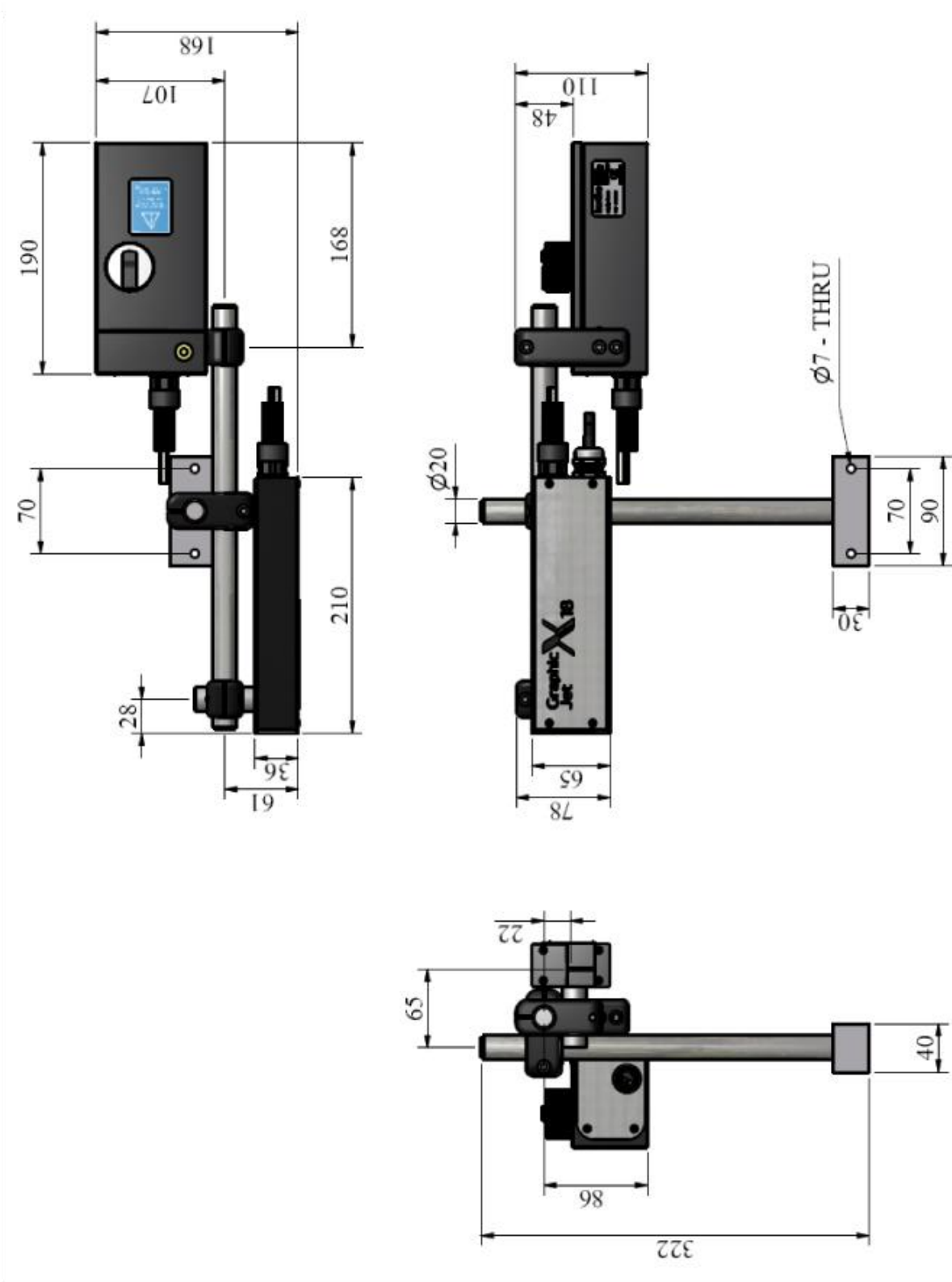

Coding unit X54 and Bracket

Dimensions are metric [mm]

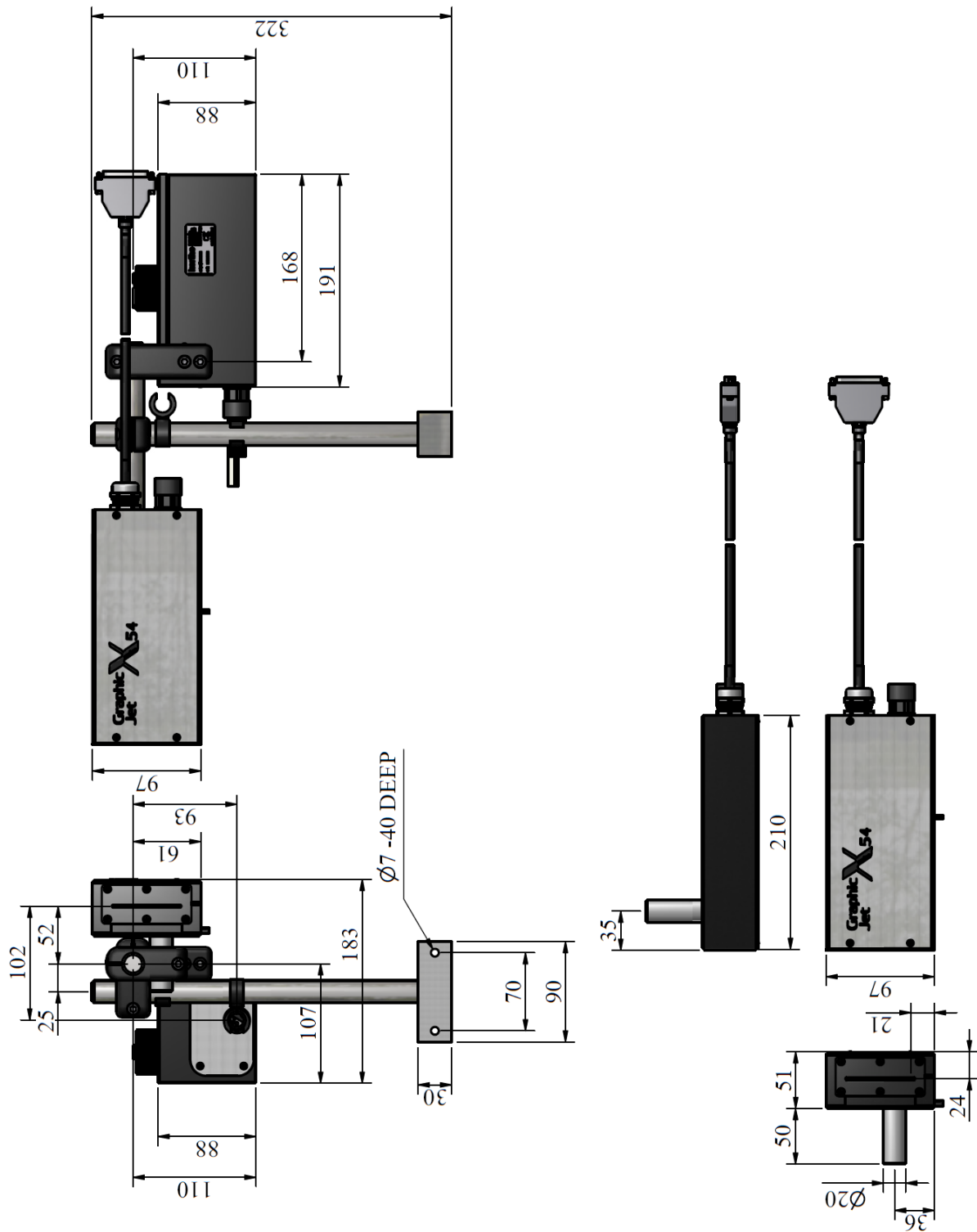

Coding unit X72 and Bracket

Dimensions are metric [mm]

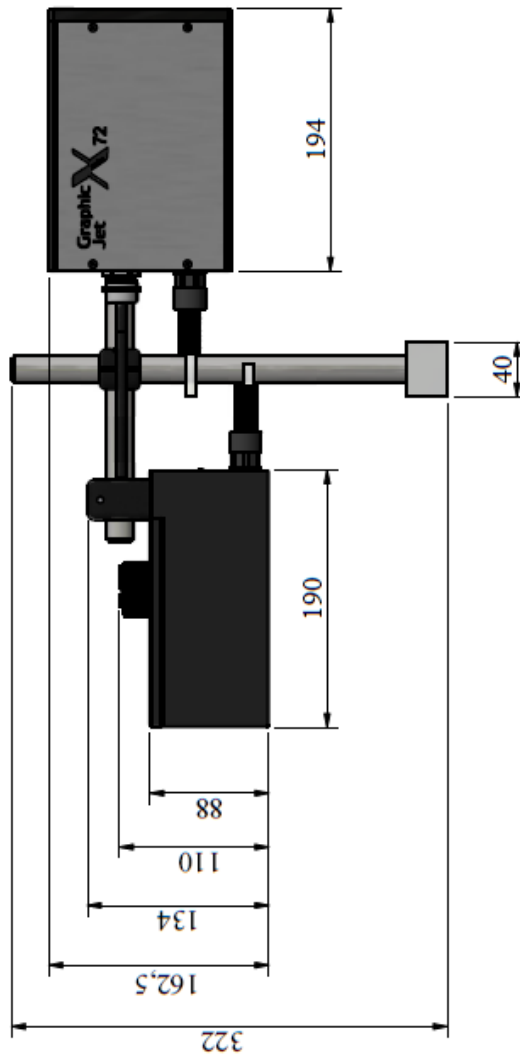
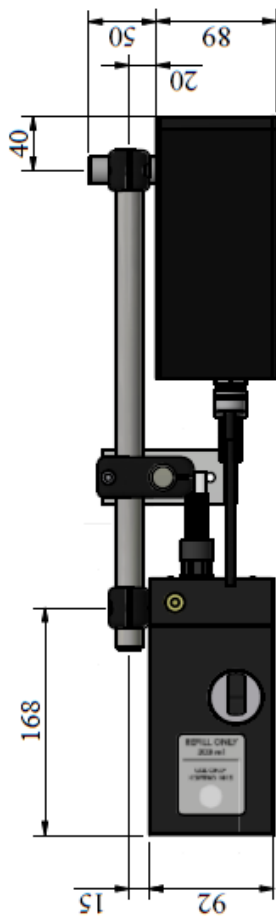
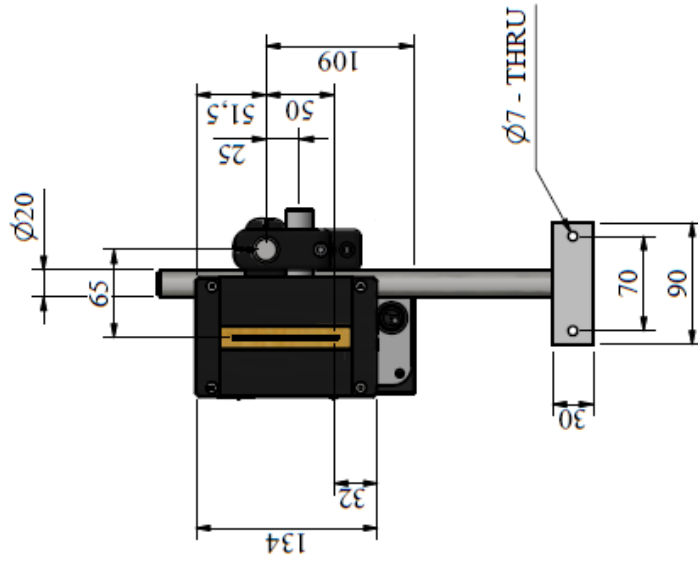

Control unit

Dimensions are metric [mm]

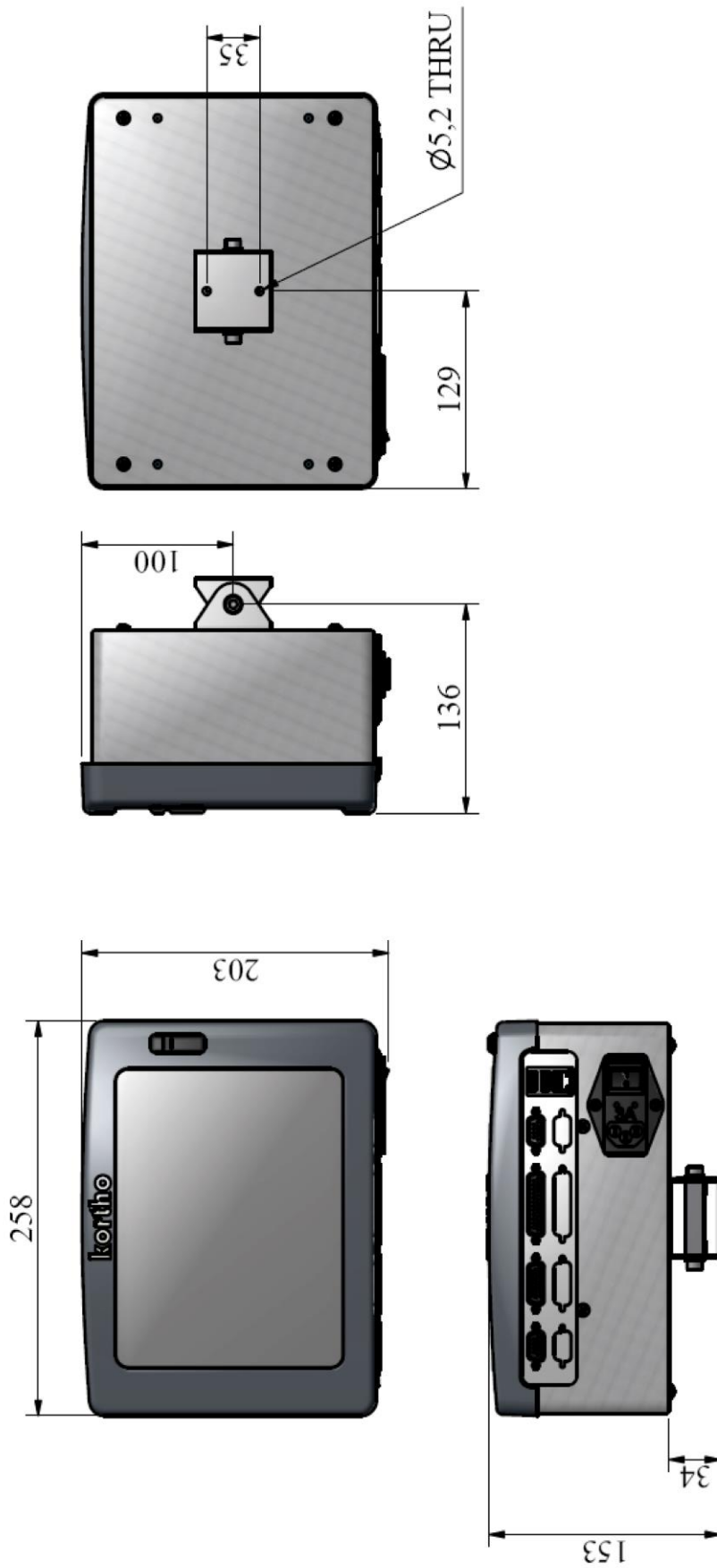

Control unit and Bracket

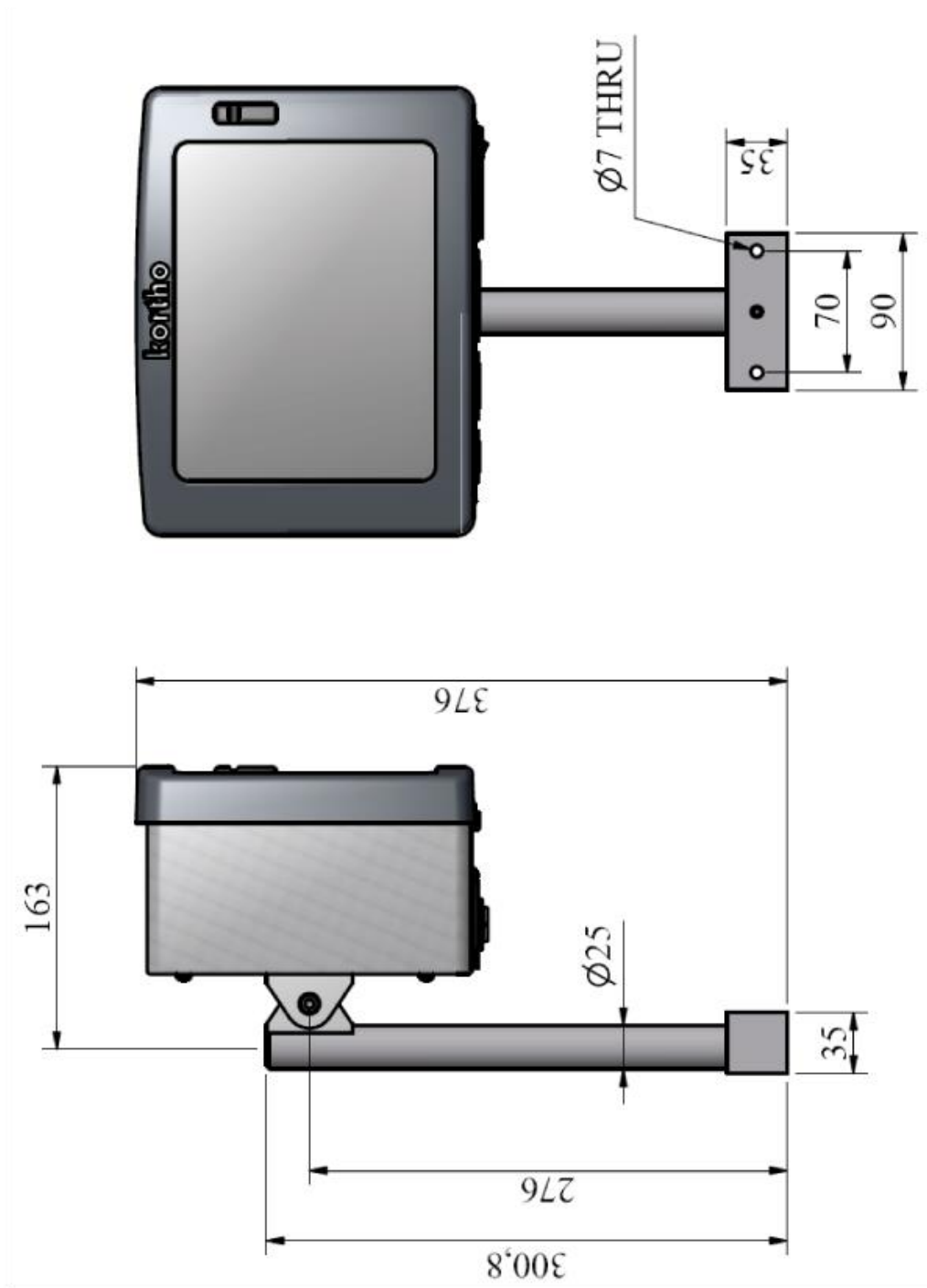

Dimensions are metric [mm]

Appendix C Part lists & illustrations

Coding unit X18, X18+ and X18si C-2

Coding unit X54 C-4

Coding unit X72 C-6

Standard bracket control unit TsC20..... C-10

Coding unit X18, X18+ and X18si

817752 Coding unit X18					
Line	Part no.	Description	Line	Part no.	Description
1	160802	Filter 14 micron	12	321045	Sealing level switch 18P
2	160872	Prime balloon KGJ	13	326279	Gasket inksystem X18
3	161165	Hose socket, bus, filter	14	326352	Cap printhead coding unit X18
4	164048	Hose socket screw bus, filter	15	326365	Gasket hood X18
5	164315	Libel level KGJ	16	326381	Gasket printhead X18
6	164331	Level switch X18	17	810864	Printhead KGJ
7	164818	M. ink tube 4/2,5 transparant	18	817584	Head PCB X18
8	168531	Cable tie 2,5x11, blue	19	817765	Cross clamp D=20 X18
9	167144	M. ink tube 5/3,0 transparant	20	817778	Cable alimentation X18 - 3M
10	317504	Base support	21	818338	Cover filling system X-series
11	317517	Bracket shaft	22		

818157 Coding unit X18+					
Line	Part no.	Description	Line	Part no.	Description
1	160802	Filter 14 micron	12	321045	Sealing level switch 18P
2	160872	Prime balloon KGJ	13	326279	Gasket inksystem X18
3	161165	Hose socket, bus, filter	14	326352	Cap printhead coding unit X18
4	164048	Hose socket screw bus, filter	15	326365	Gasket hood X18
5	164315	Libel level KGJ	16	326381	Gasket printhead X18
6	164331	Level switch X18	17	817584	Head PCB X18
7	164818	M. ink tube 4/2,5 transparant	18	817765	Cross clamp D=20 X18
8	168531	Cable tie 2,5x11, blue	19	817778	Cable alimentation X18 - 3M
9	167144	M. ink tube 5/3,0 transparant	20	817877	Printhead X18+
10	317504	Base support	21	818338	Cover filling system X-series
11	317517	Bracket shaft	22		

818227 Coding unit X18 si					
Line	Part no.	Description	Line	Part no.	Description
1	160802	Filter 14 micron	12	325929	Gasket inksystem X18si
2	160872	Prime balloon KGJ	13	325932	Gasket hood X18si
3	161165	Hose socket, bus, filter	14	325945	Gasket printhead X18si
4	164048	Hose socket screw bus, filter	15	325958	Sealing level switch X18si
5	164315	Libel level KGJ	16	326352	Cap printhead coding unit X18
6	164331	Level switch X18	17	810864	Printhead KGJ
7	164818	M. ink tube 4/2,5 transparant	18	817469	Cover filling system X18si
8	168531	Cable tie 2,5x11, blue	19	817584	Head PCB X18
9	167144	M. ink tube 5/3,0 transparant	20	817765	Cross clamp D=20 X18
10	317504	Base support	21	817778	Cable alimentation X18 - 3M
11	317517	Bracket shaft	22		

Coding unit X18, X18+ and X18si

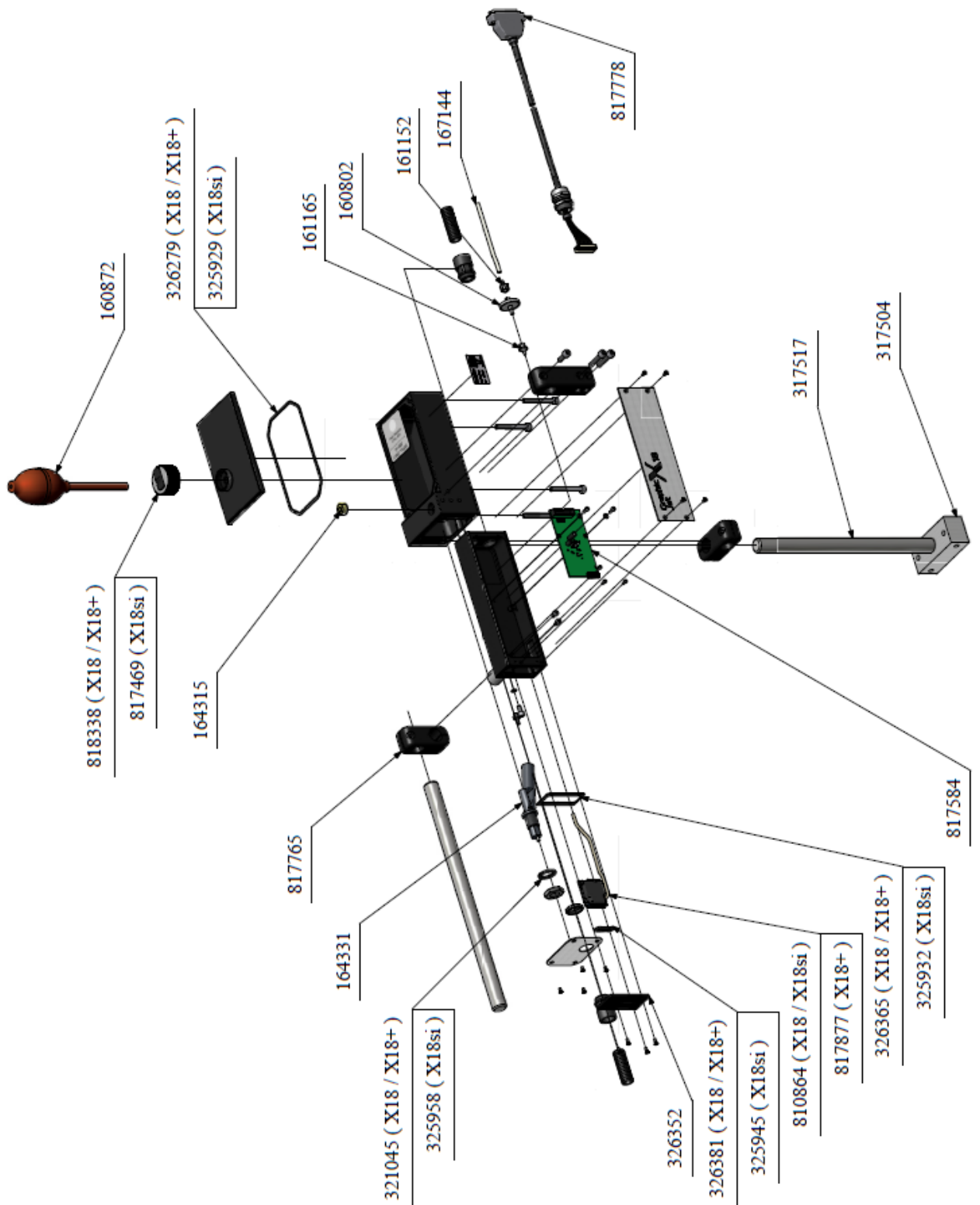

Coding unit X54

817555			Coding unit X54		
Line	Part no.	Description	Line	Part no.	Description
1	160802	Filter 14 micron	12	317517	Bracket shaft
2	160872	Prime balloon KGJ	13	321045	Sealing level switch 18P
3	164315	Libel level KGJ	14	326279	Gasket inksystem X18
4	164331	Level switch X18	15	817472	Clip X54
5	164945	m.Ink tube 6/4 naturel PE	16	817485	Cover PH X54
6	168639	Printhead X54	17	817501	Cable printhead X54
7	168725	Hose socket 32, bus	18	817765	Cross clamp D=20 X18
8	325987	Cap printhead X54	19	817778	Cable alimentation X18 - 3M
9	326044	Gasket printhead X54	20	818239	PCB printhead X54
10	326114	Foam Gasket PH X54	21	818338	Cover filling system X-series
11	317504	Base support	22		

Coding unit X54

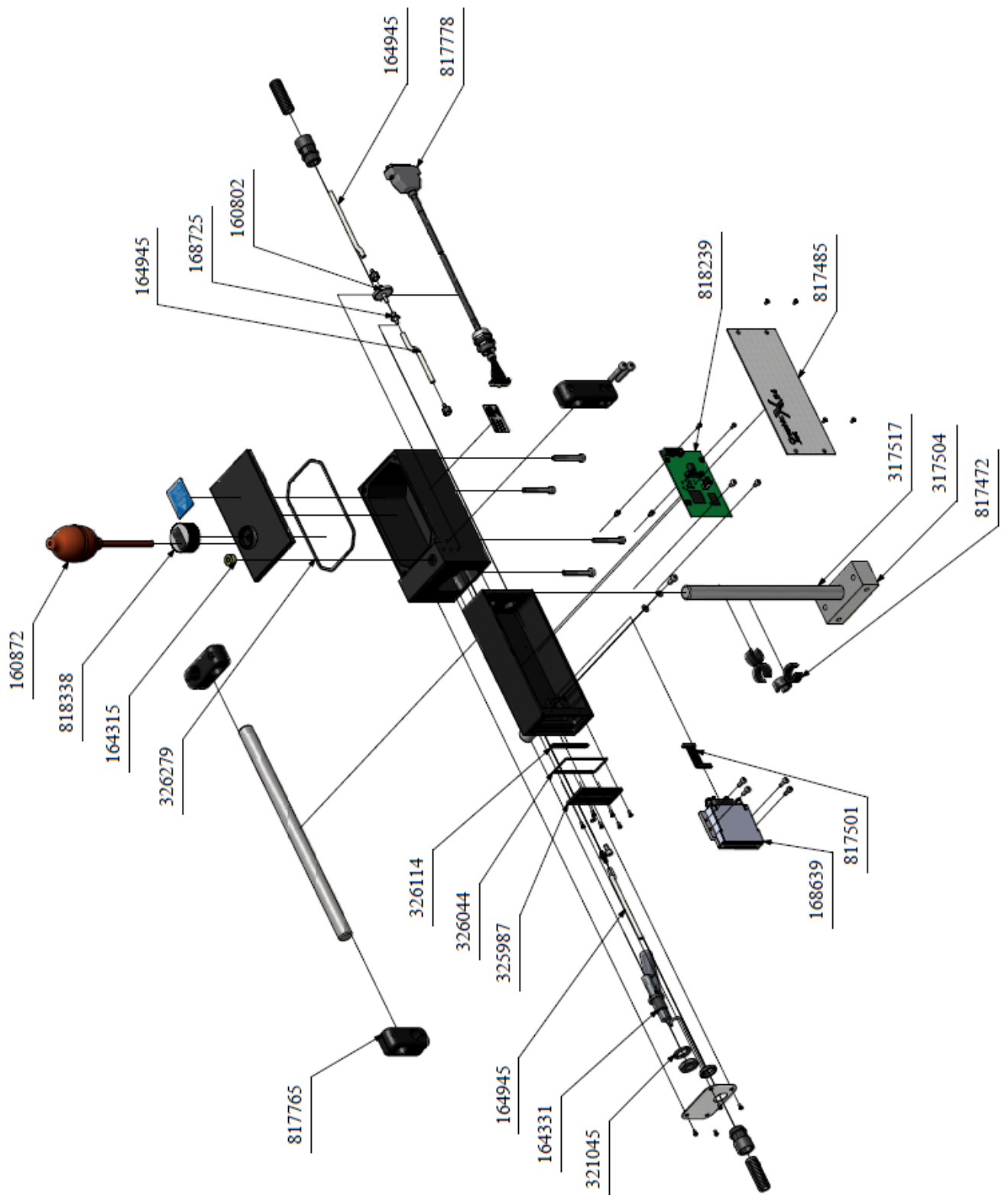

Coding unit X72

819041			Coding unit X72		
Line	Part no.	Description	Line	Part no.	Description
1	160802	Filter 14 micron	13	319139	Shaft 18P
2	160872	Prime balloon KGJ (not shown)	14	327024	Hose connector M5 stainless steel
3	164315	Libel level KGJ	15	326127	Sealing level switch 18P
4	164331	Level switch X18	16	326279	Gasket inksystem X18
5	169257	m.Ink tube 8,0/4,8 transparant	17	326982	Cap printhead X72
6	169145	m.Ink tube 6,4/3,2 transparant	18	819054	Cover PH X72
7	169228	Printhead X72	19	169285	Cable printhead X72
8	169314	Hose socket 4.0, bus	20	817765	Cross clamp D=20 X18
9	164048	Hose socket 32, bus	21	817778	Power & signal cable X18 - 3M
10	169269	Connection set PH-X72, oil, 3 parts	22	169244	PCB printhead X72
11	326982	Cap printhead X72	23	818338	Cover filling system X-series
12	818704	Standard vertical support			

Coding unit X72

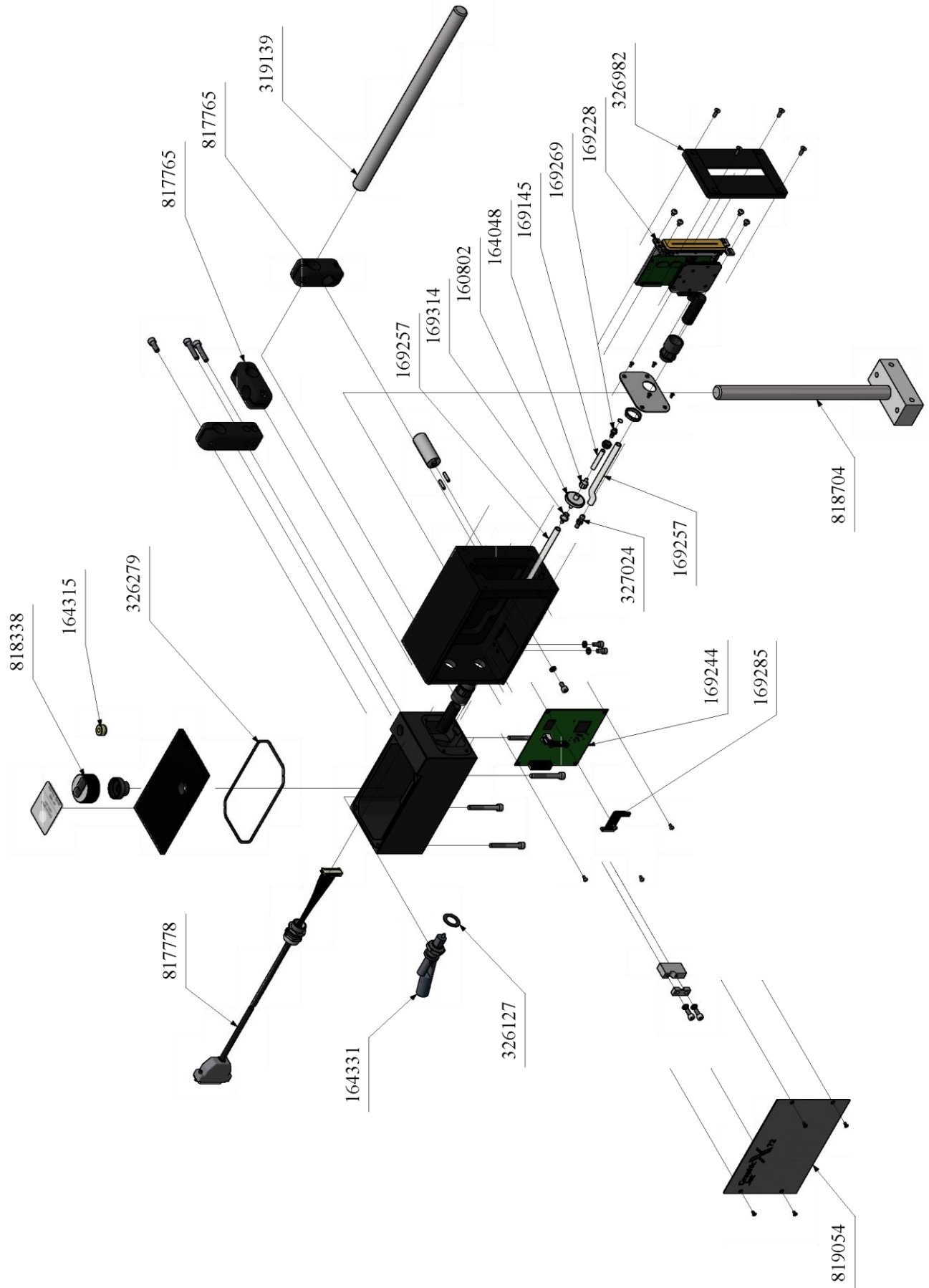

APPENDIX C, PARTS & ILLUSTRATIONS

Control unit TsC20-X

817807			Controller TsC20-X		
Line	Part no.	Description	Line	Part no.	Description
1	164427	Power cord Euro-connector	10	326451	Front controller TsC20
2	168041	Filter controlbox 1A	11	817781	CPU board controller TsC20 - X18
3	168264	M.cord 1,6 EPDM 70deg shore	12	817991	Power supply board controller TsC20 - X18
4	168277	Touchscreen TsC20	13	818017	Power cable 48VDC TsC20
5	168429	Power supply TsC20-X18 - 45Watt	14	818029	Power entry cable TsC20
6	168458	Cable touchscreen TscC20, 8 pins	15	818032	Cable safety earth TsC20
7	168461	Cable touchscreen TsC20, 40 pins	16	818045	Cable power/CPU board TsC20
8	323132	Flap USB TsC26	17	818061	Cable USB connector, L=152
9	326419	Cover TsC20	18		

Control unit TsC20-X duo

818131			Controller TsC20-X Duo		
Line	Part no.	Description	Line	Part no.	Description
1	164427	Power cord Euro-connector	10	326451	Front controller TsC20
2	168041	Filter controlbox 1A	11	818128	CPU board controller TsC20 - X18 - Duo
3	168264	M.cord 1,6 EPDM 70deg shore	12	817991	Power supply board controller TsC20 - X18
4	168277	Touchscreen TsC20	13	818017	Power cable 48VDC TsC20
5	169059	Power supply TsC20-X18 - 60 Watt	14	818029	Power entry cable TsC20
6	168458	Cable touchscreen TscC20, 8 pins	15	818032	Cable safety earth TsC20
7	168461	Cable touchscreen TsC20, 40 pins	16	818045	Cable power/CPU board TsC20
8	323132	Flap USB TsC26	17	818061	Cable USB connector, L=152
9	326419	Cover TsC20	18		

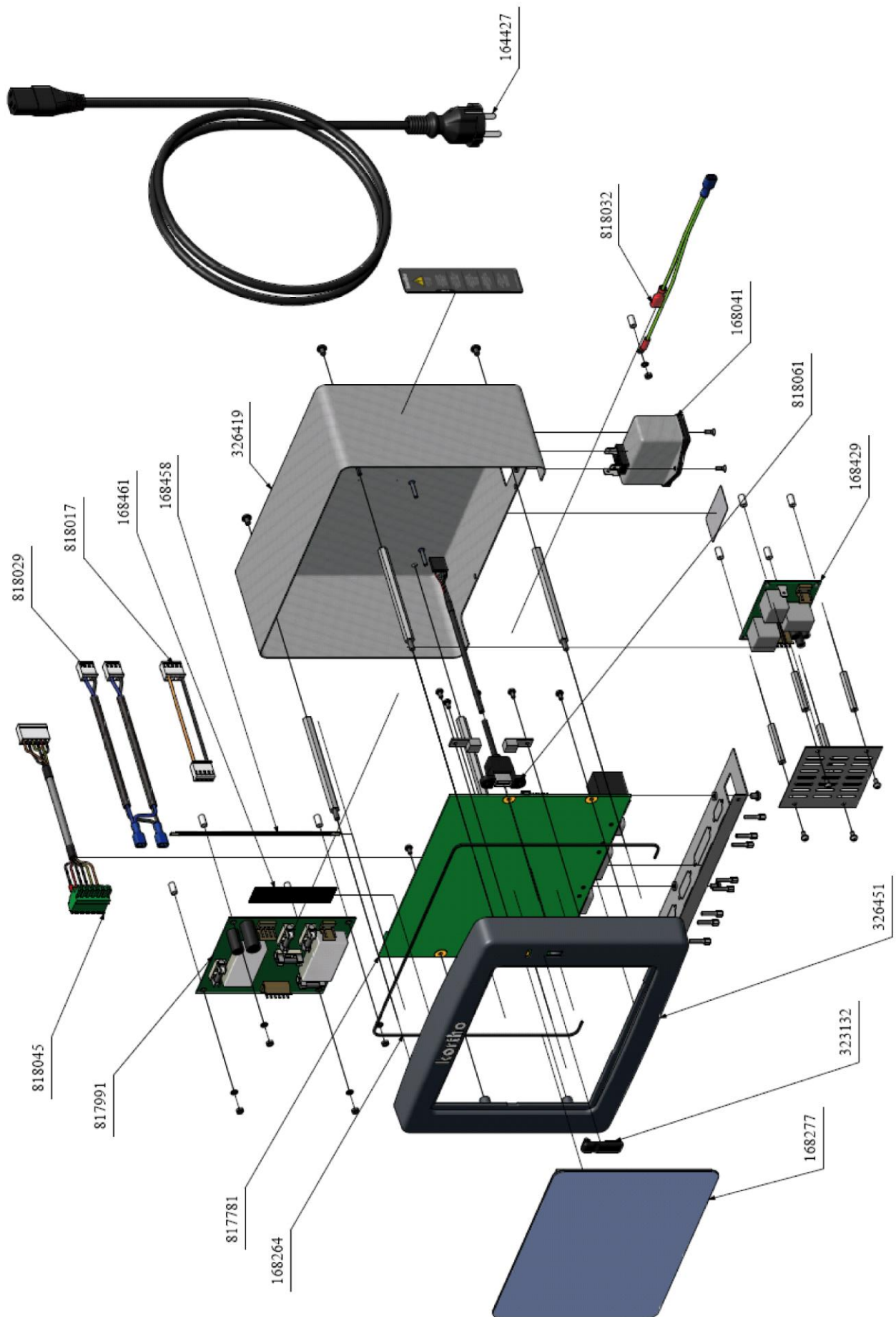

Standard bracket control unit TsC20

818115			Standard bracket controller TsC20		
Line	Part no.	Description	Line	Part no.	Description
1	326492	Bracket shaft TsC20	2	326505	Base support TsC20

Standard bracket control unit TsC20

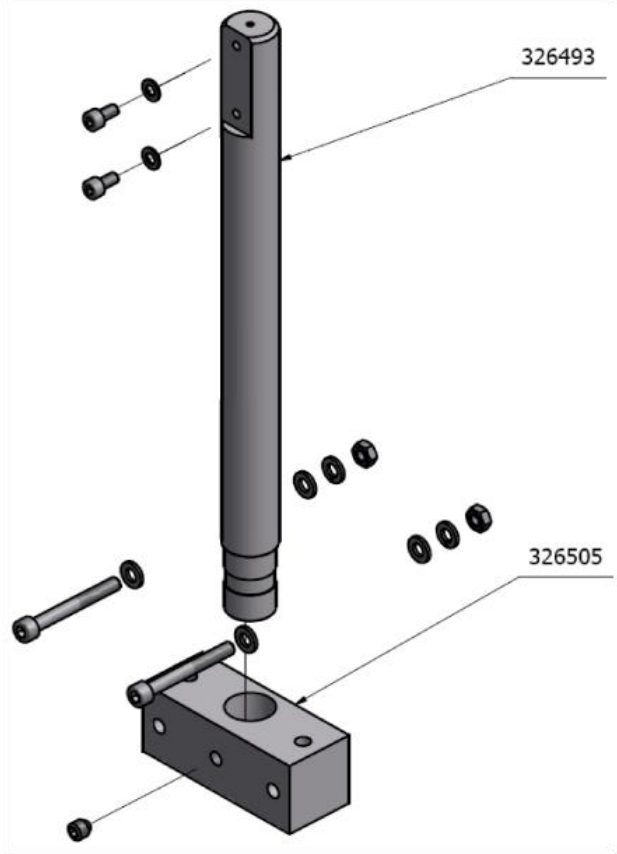

Appendix D Connections

Control unit Connector Plate..... D-2

X3 Schematic diagram (input) D-3

X3 Schematic diagram (output) D-4

X3 Circuit diagram (input) D-5

X3 Circuit diagram (output)..... D-6

X3 Schematics diagram User D-7

Control unit Connector Plate

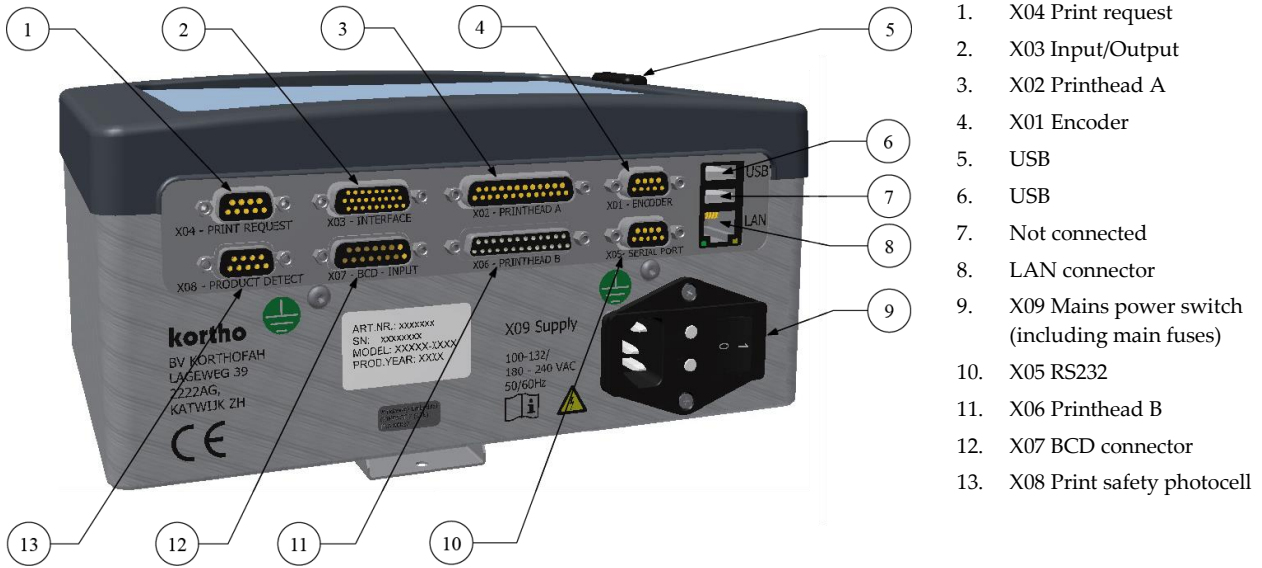

Item	Description	Connector type
X01	Encoder	DB 9-ways, socket
X02	Printhead A	DB 25-ways, socket
X03	Input/output	HD 26-ways, socket
X04	Print request	DB 9-ways, socket
X05	RS232	DB 9-ways, socket
X06	Printhead B	DB 25-ways, socket
X07	BCD connector	DB 15-ways, socket
X08	Sensor input product detect to add BCD code to print list	DB 9-ways, socket
X09	Mains power switch with 2 fuses	2,5A (s)
USB	USB	USB
LAN	LAN connector	RJ45, socket

X3 Schematic diagram (input)

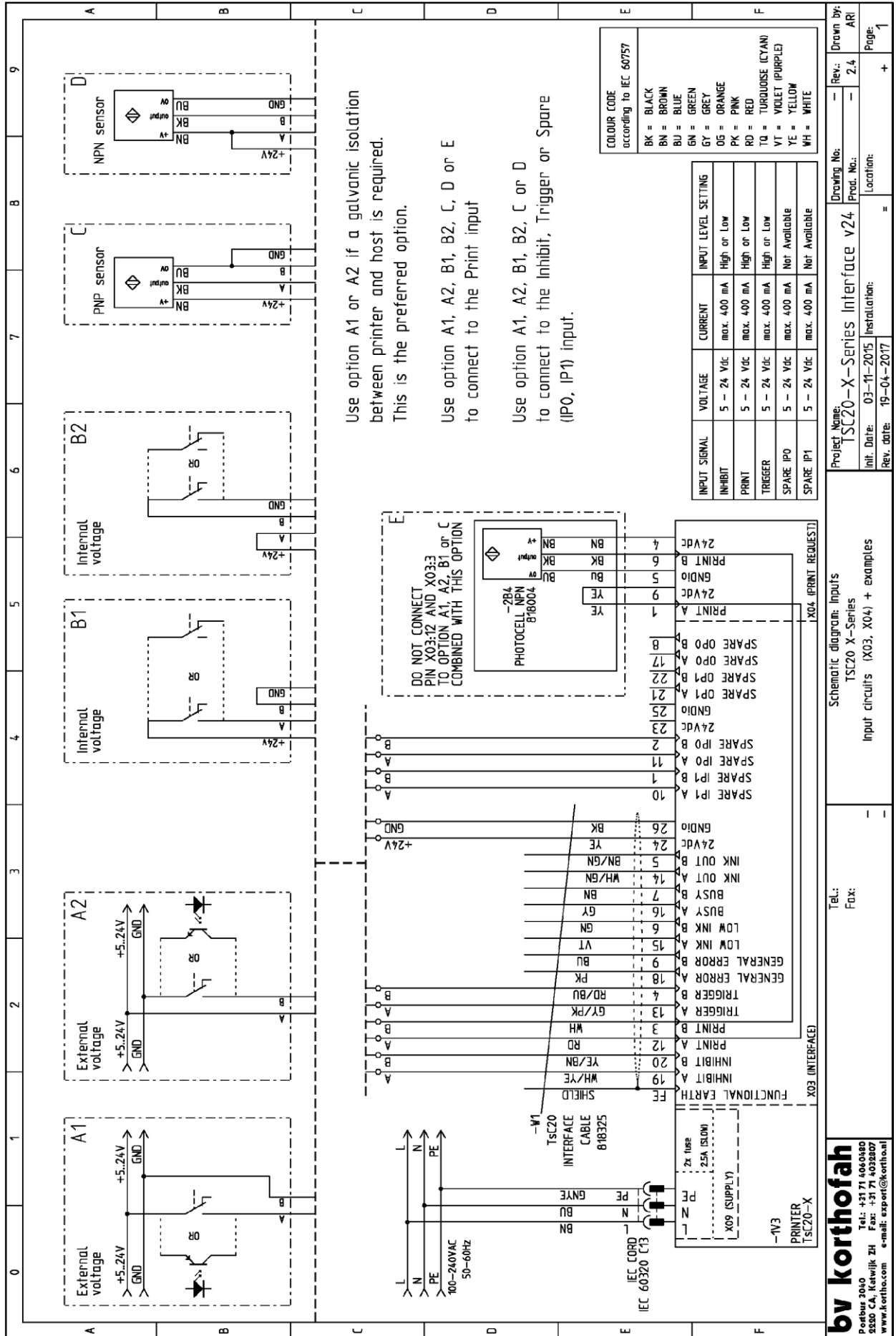

bv korthofah
 Poibus 2040
 Tel.: +31 71 4060480
 5220 CA, Katwijk ZH Fax: +31 71 4032807
 www.kortho.com e-mail: export@kortho.nl

X3 Schematic diagram (output)

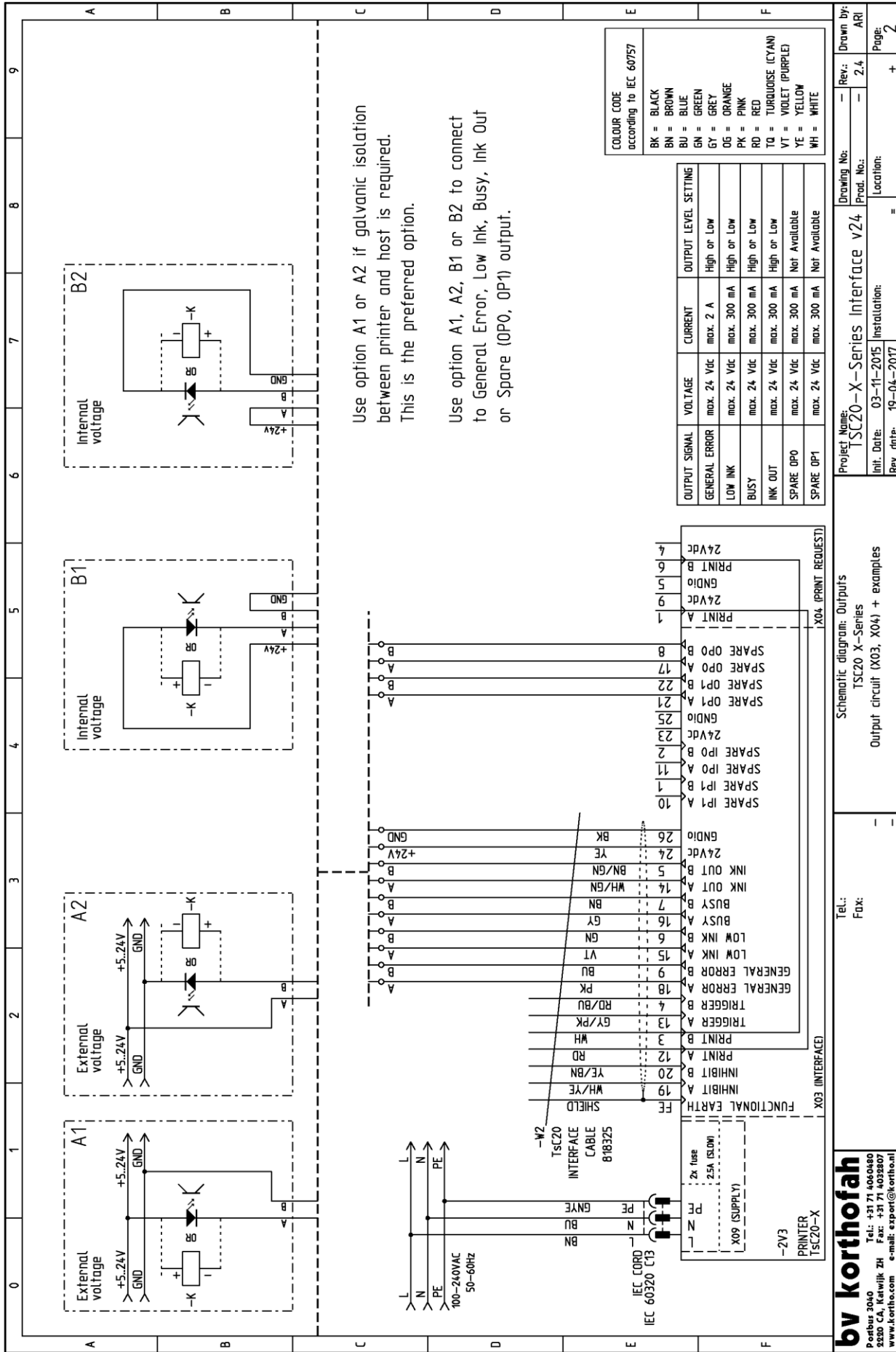

Project Name: TSC20-X-Series Interface v24
 Drawing No: - Rev.: 2.4
 Prod. No: -
 Location: -
 Init. Date: 03-11-2015 Installation: =
 Rev. date: 19-04-2017

Schematic diagram: Outputs
 TSC20 X-Series
 Output circuit (X03, X04) + examples

Tel.: -
 Fax: -

bv korthofah
 Porbus 3040 Tel.: +31 71 40320480
 5250 CA, Katwijk ZH Fax: +31 71 40328707
 www.kortho.com e-mail: export@kortho.nl

X3 Schematics diagram User

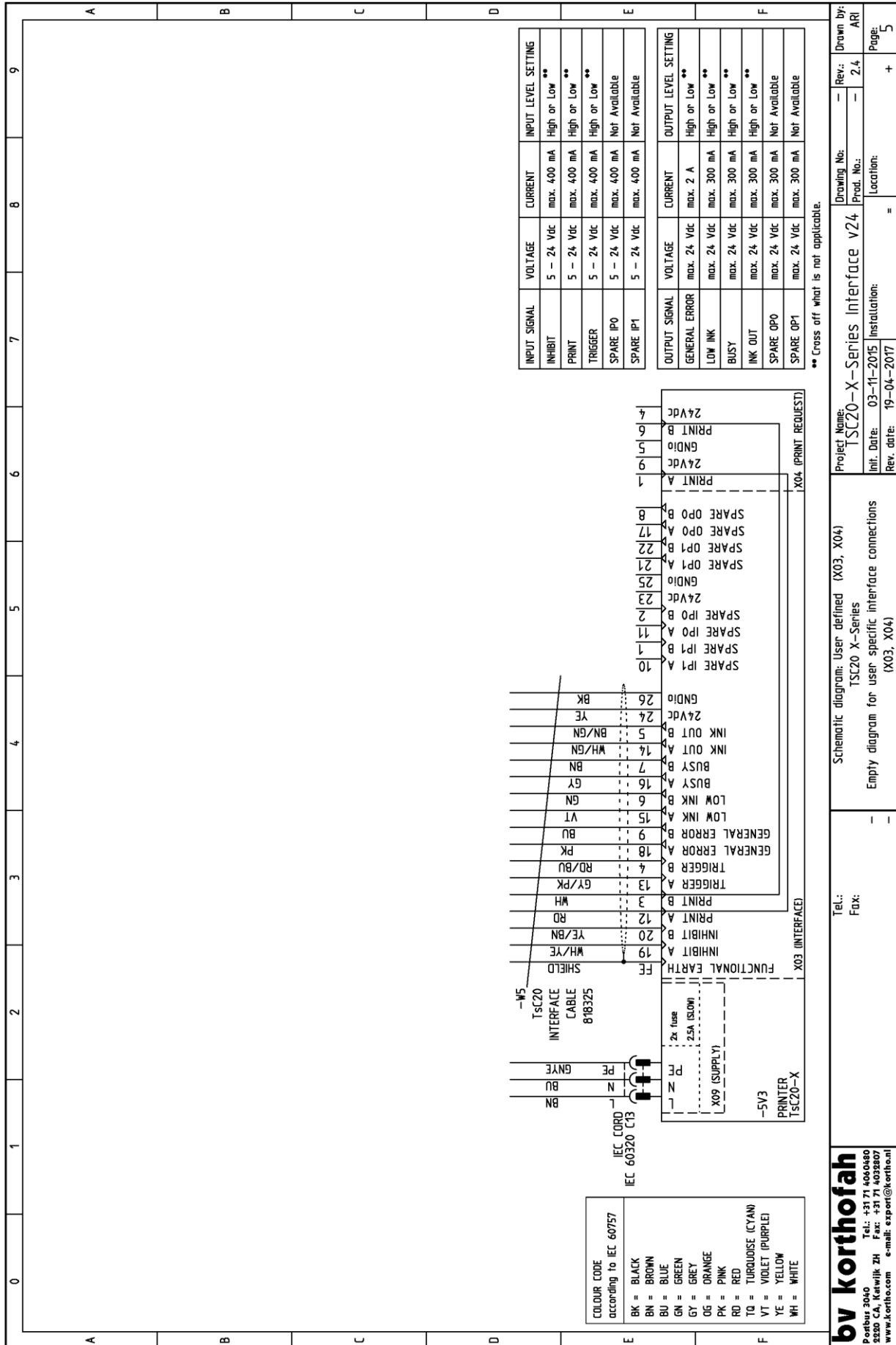

This diagram can be used to note the specific user settings.

X07 BCD-input connections

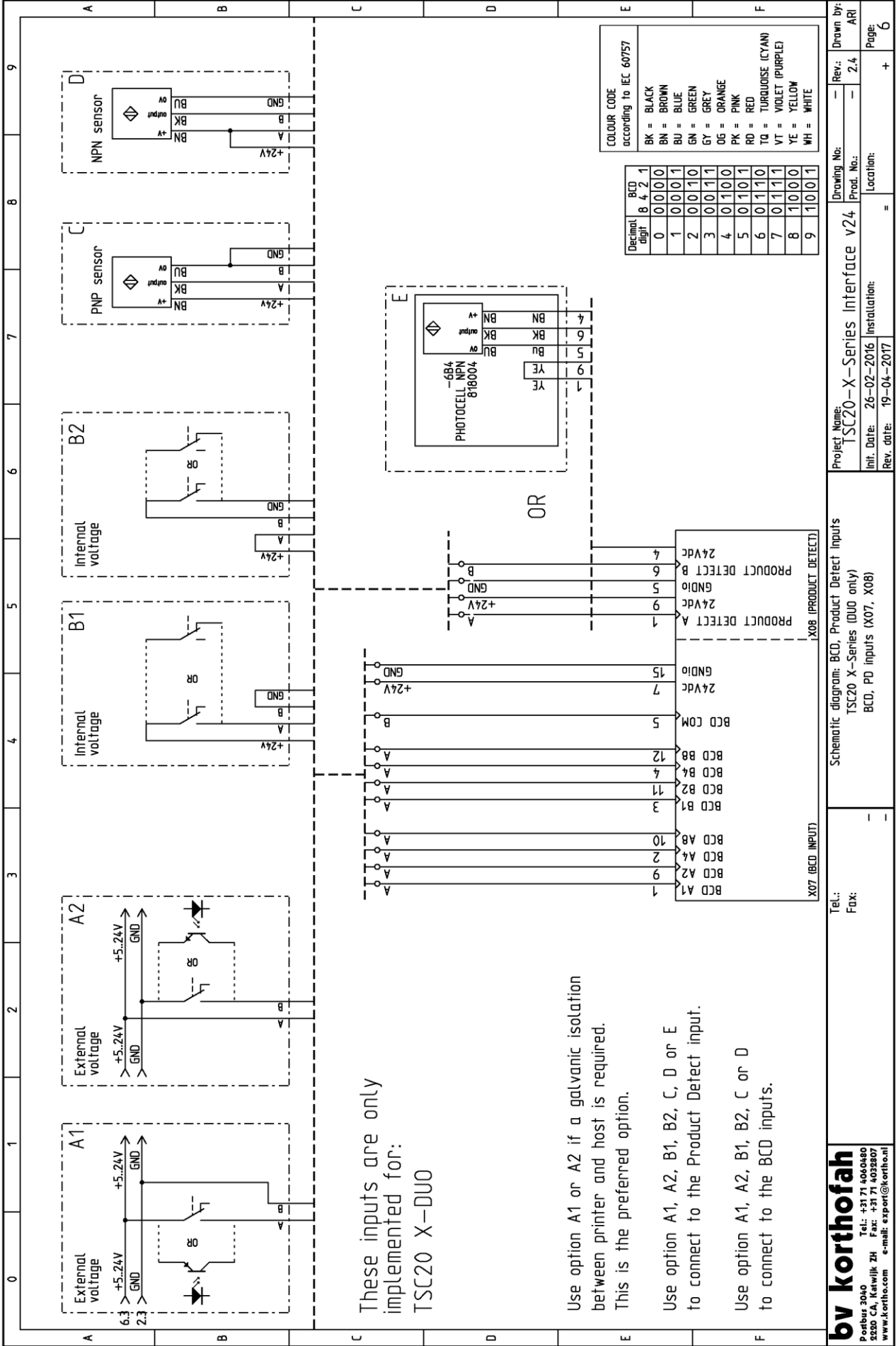

Project Name: TSC20-X-Series Interface V24
Init. Date: 26-02-2016
Rev. date: 19-04-2017

Drawing No.: V24
Prod. No.:
Location:

Rev.: 2.4
ARI:
Page: 6

Schematic diagram: BCD, Product Detect inputs
TSC20 X-Series (DUO only)
BCD, PD inputs (X07, X08)

Tel.:
Fax:

bv korthofah
Postbus 2040
5220 CA, Katwijk ZH
www.kortho.com
Tel.: +31 71 4060460
Fax: +31 71 4032807
e-mail: export@kortho.nl

X07 BCD input schematics

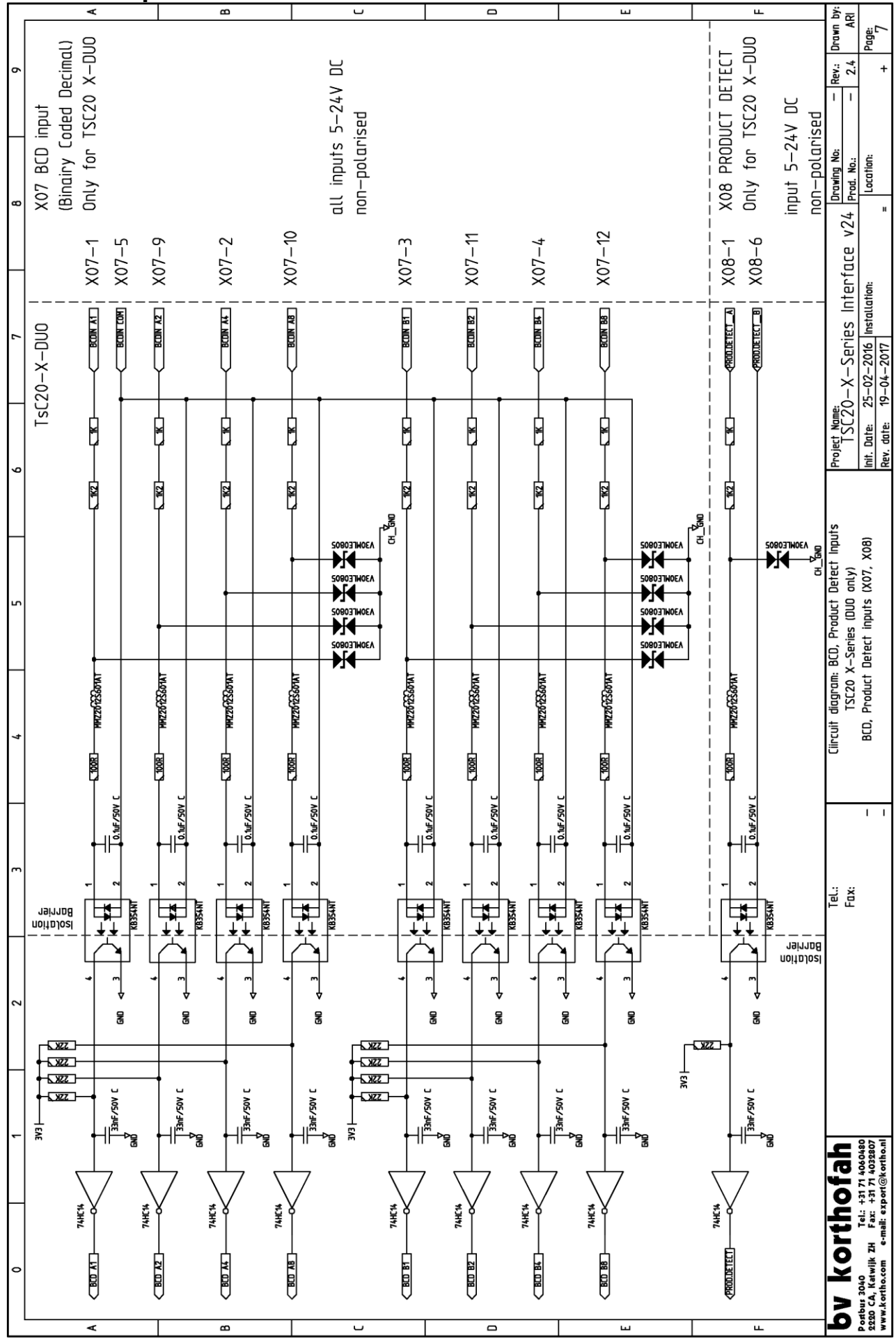

Project Name:	TSC20-X-Series Interface v24	Drawn by:	ARI
Int. Date:	25-02-2016	Rev.:	2.4
Rev. date:	19-04-2017	Location:	
Installation:		Page:	7

Circuit diagram: BCD, Product Detect Inputs
TSC20 X-Series (DUO only)
BCD, Product Detect inputs (X07, X08)

Tel: -
Fax: -

bv korthofah
 Postbus 3040
 5230 CA, Katwijk ZH
 www.kortho.com
 Tel: +31 71 4060480
 Fax: +31 71 4033007
 e-mail: export@kortho.nl

Appendix E NiceLabel driver tutorials

- Installation and configuration of the driver E-2
 - Function of the driver E-2
 - Versions of the driver E-2
 - Installation of the driver E-3
 - Configuration of the driver E-6
 - Summary E-8
- Downloading a label through USB E-9
 - Introduction E-9
 - Installation of the driver E-9
 - Download a label through USB E-10
- Sending a label on a network E-11
 - Introduction E-11
 - Installation of the driver E-11
 - Sending a label on a network E-11

Installation and configuration of the driver

This appendix is based on the general description for the installation and configuration of the driver. The procedures are based on the Kortho GraphicJet X18. It speaks for itself that if one like to perform the procedures for the other models of the GraphicJet X-series, one should select the desired printer model instead of the Kortho GraphicJet X18.

Function of the driver

The printer driver can be installed on a PC/laptop in order for a printer to receive and execute print commands from a PC/Laptop. Every printer has its own driver. In order to control 5 individual printers with 1 PC/Laptop, it is therefore required to have 5 individual drivers on that PC/Laptop. The driver for the Kortho printers (named NiceDriver) is Windows based. This means that the driver (and with that the Kortho printers) can be controlled by all common Windows systems. Most ERP systems are also capable of printing to a Windows driver. This means that one could control all Kortho printers in a production plant by using 1 central ERP system (SAP, Microsoft Dynamics NAV etc.).

For every printer under control, there is a driver installed on the PC/Laptop:

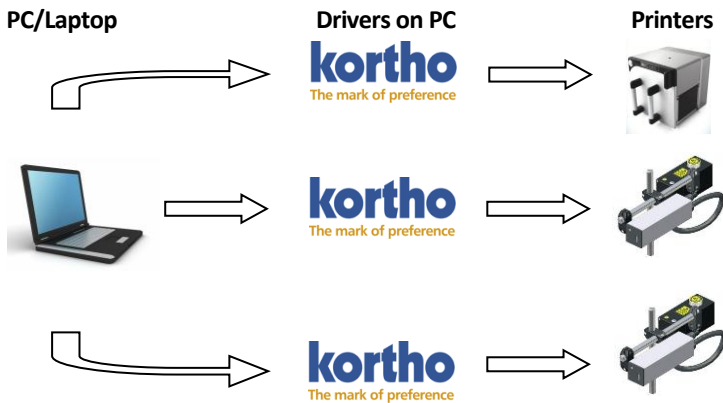

So if there are several lines and/or several printers that should receive print commands from 1 single PC/Laptop, there should be a driver installed for each printer. The driver translates every signal sent from the PC/Laptop separately, and translates these signals into a signal the printer can create an image out of.

Versions of the driver

In order to have a driver communicate correctly with a printer, it is important for the driver's version to be compatible with the printer's firmware version. To be sure the right driver will be installed, the firmware should be checked first. To check the firmware version of the printer:

1. Touch the *Information* icon.
2. Touch the *System info* button.

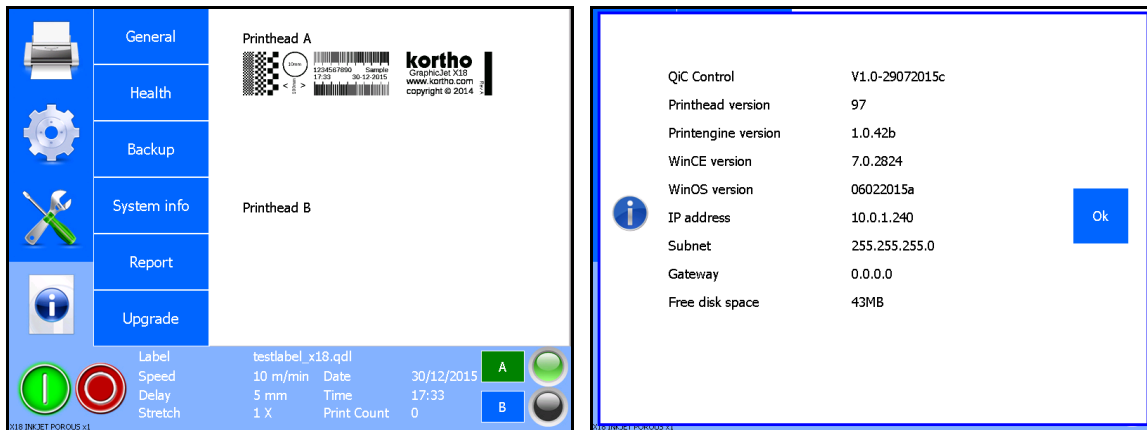

After checking the firmware version the compatible driver can be downloaded from the Kortho website (www.kortho.com).

In general the following firmware-driver combinations are compatible:

- Driver version: 4.6.63 (Build 3230) and higher
- Minimal Printer Firmware version: V1.0-16032011

For firmware lower than this version, use driver version 4.6.44 or turn the two-way support off at the driver's port setting.

Installation of the driver

As soon as the compatible driver has been downloaded, it can be installed on the PC/Laptop which is going to control the printer(s).



Beware:

If the label needs to be downloaded through a USB thumbdrive one should set the driver accordingly, see Appendix E, Downloading a label through USB. The description below is based on the situation in which the label is sent to the printer through the Ethernet.

To install the driver:

1. Unzip the downloaded file.
2. Start the installation by executing the program PrnInst.exe.
3. Click *Next*.

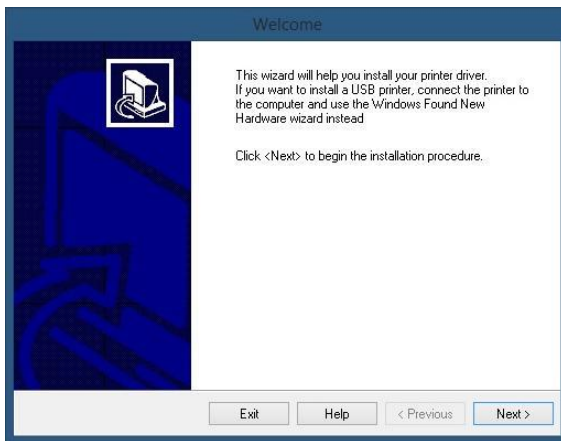

4. Accept the conditions and click *Next*.

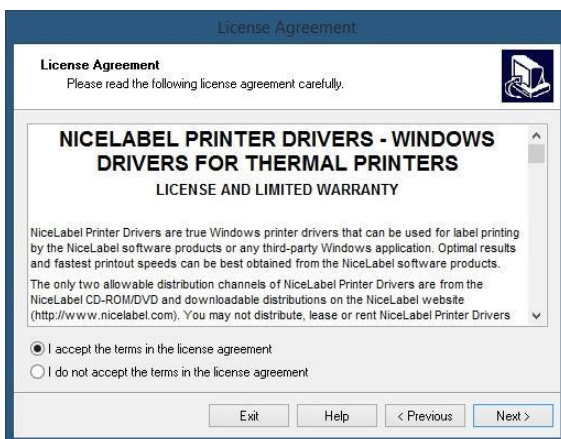

5. Select the desired printer and click *Next*.

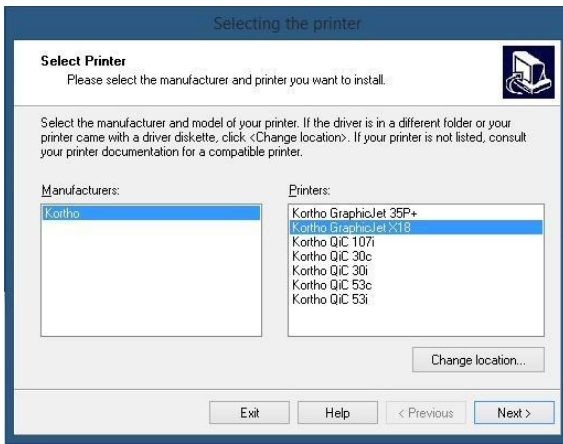

6. Click *Add Port*.

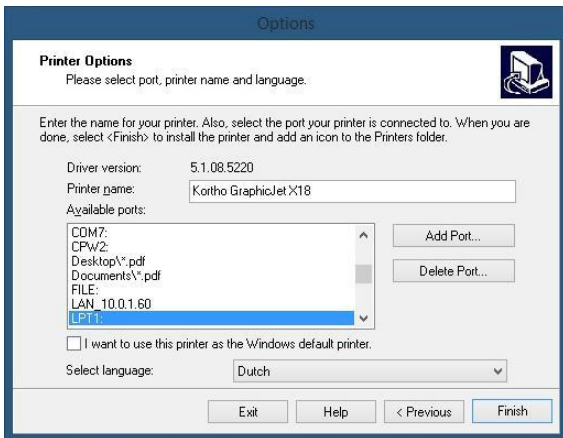

7. The Advance Port Monitor Configuration will appear. Execute the following steps:
- a. Enter printer's IP address (Port name automatically changes with the IP address, for example IP: 192.168.1.10).
 - b. Optionally enter a Name for the port (So that the port is easily recognized, for example: X18_line).
 - c. Enter the Port number (With a Korho printer this is always 14322, this is the control unit's fixed number).
 - d. Click OK (A printer port will be created).

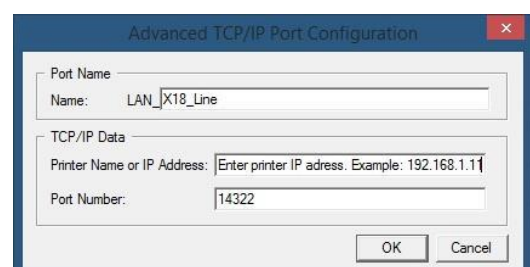
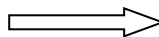
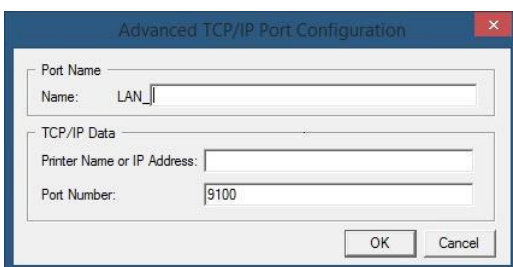

8. The printer is now selected automatically out of the list of available ports.
9. Optionally:
 - a. Give the printer a Printer name.
 - b. Select a language for the printer's properties.
 - c. Select the printer as standard printer.

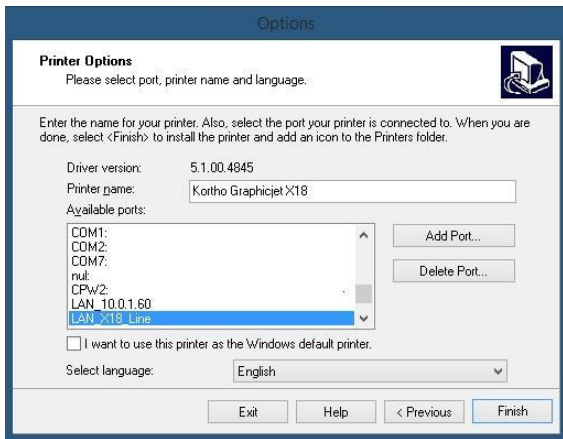

10. Click *Finish* to close the screen. A progress screen will appear installing the driver.
11. Open the printer configuration screen in Windows. This is found in Windows “Start” or in “Start > Configuration screen”. The printer is added as shown below:

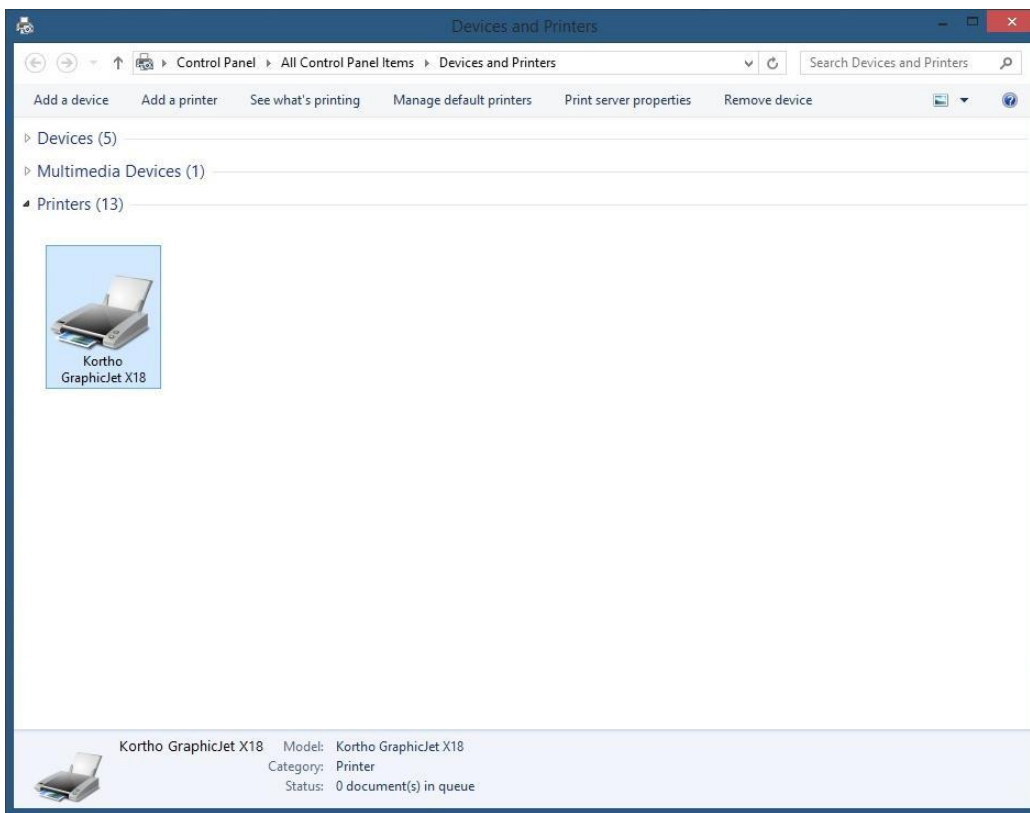

12. Right click on the printer and select *Printer properties*.

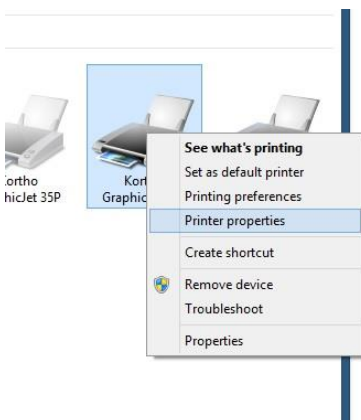

13. Select the tab *Ports*.
14. Uncheck the *Enable bidirectional support*.
15. Select the tab *General*.
16. Click *Print Test Page* to test the installation. The printer will print the Windows logo.

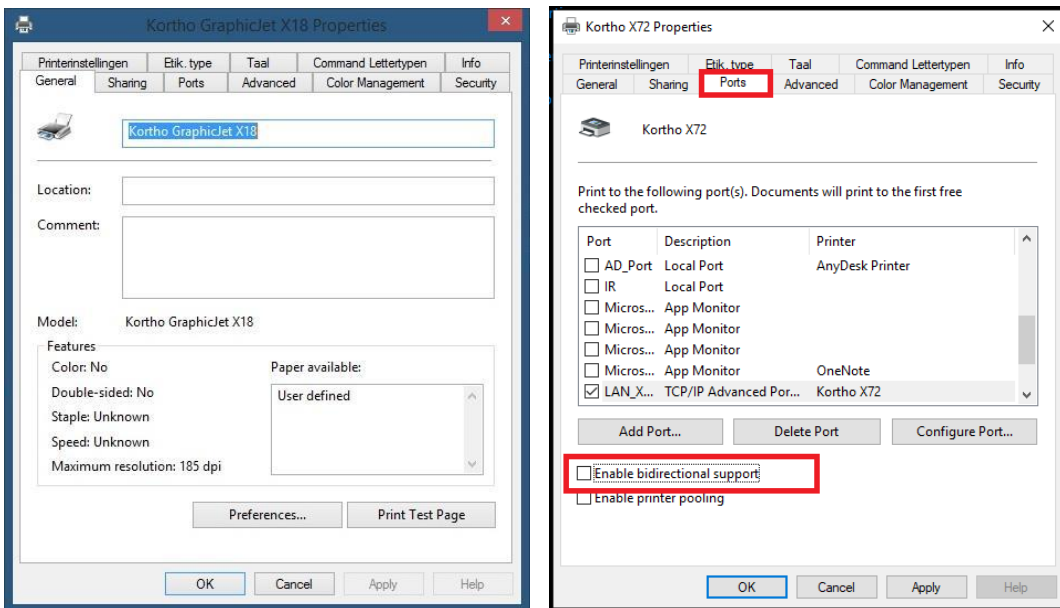

Configuration of the driver

In order to more easily work with the printer and set up labels, a standard label type can be set.

1. Open the printer configuration screen in Windows. This is found in Windows "Start" or in "Start>Configuration screen".
2. Right click on the printer and select *Properties*.
3. Select the tab *Etik. Type*.

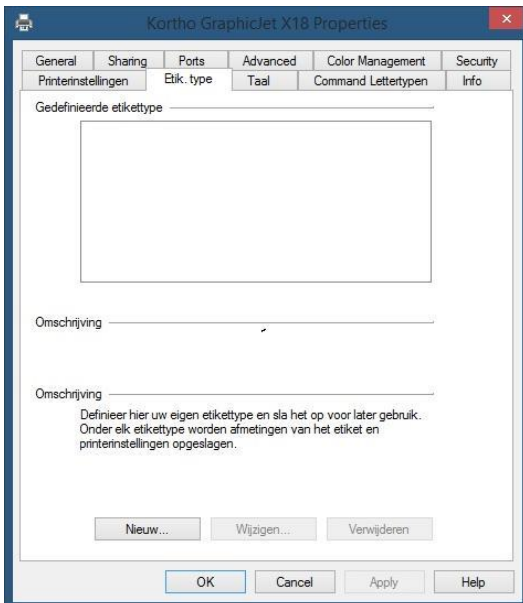

4. Click *New (Nieuw)*.

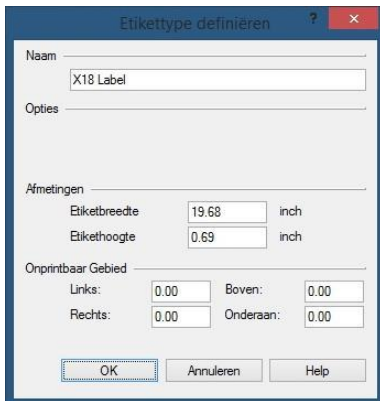

5. Enter the Label length and Label width (Labels can be defined, so that the label stays within certain dimensions. That is how label programs like NiceLabel take the printer's printable surface into account).
6. Enter a Name for the label.
7. The values for unprintable areas for the Kortho printers are already correctly set to 0,0.
8. Click *OK* to close the screen.
9. The label with the right dimensions of printable area (which will be taken into account by the printer) is now added to the list of labels for the printer "Kortho X18_Line 1". When using several Kortho printers the standard label will have to be added separately for each printer.

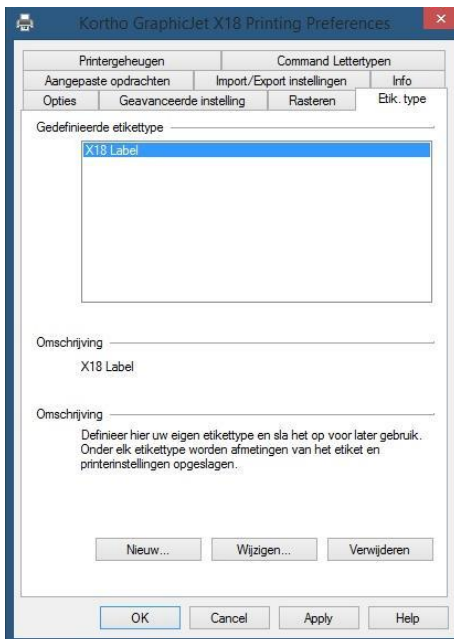

10. Click *New* (Nieuw) again to add another label definition or click *OK* to close the screen.

When designing a label in a designing program one can select the printer "Kortho X18_Line 1" and after that "X18 Label" as a label/tag/paper size (name depends on the label design program). The program will take the printers parameters of the selected label/tag/paper size into consideration.

Because the Kortho driver was developed by NiceLabel, the driver can define NiceLabel's settings. Within NiceLabel, the only options available will be actions that the printer will actually support. Due to this, the margins for errors due to wrong configuration/settings is limited and it is beneficial to the user friendliness. To adjust these settings:

1. Open the printer configuration screen in Windows. This is found in Windows "Start" or in "Start > Configuration screen".
2. Right click on the printer and select *Printer properties*.

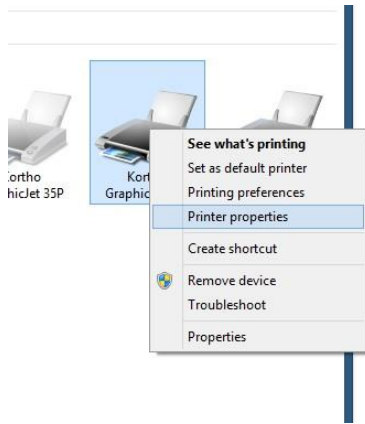

3. Select the tab *Advanced settings* (Geavanceerde instelling).
4. Check the box *Use printer settings* (Gebruik printer instellingen) to let the printer parameters manage the label programs settings. If this box is not checked, the driver will overwrite the printer's settings the moment a print command is sent.
5. Click *OK* to close the screen.

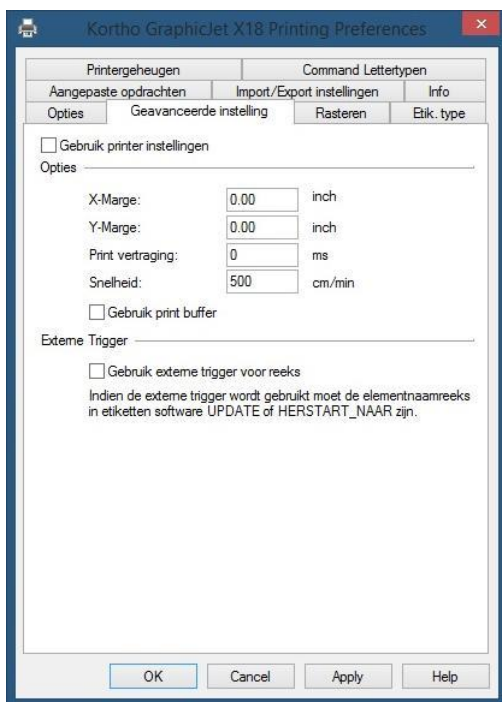

Summary

The Kortho GraphicJet X18 can be installed on any Windows PC/Laptop in the same way a “normal” desktop printer is installed. After installation the printer can be chosen amongst the other (desktop) printers currently in use on the PC/Laptop.

After installation of the driver the printer's print area can be defined. By doing this the driver can communicate the information back to a label design program (like NiceLabel, Bartender etc.). When defining the lay-out of a label, the program will take the printer's parameters into account. With a normal desktop printer for example the parameter for the printable area is A4. With a Kortho printer the printable area depends on the printer model.

Because the driver was developed by NiceLabel, it is not only automatically certified for use with all Windows systems/Label design programs. The advantage of using NiceLabel is that while defining the label's lay-out, one can take the printer properties and setting into account. Due to this the settings (like print area, speed, contrast and method of data transfer) are automatically set correctly. So by using NiceLabel the system not only becomes more user friendly, but it also decrease the chance of errors due to incorrect settings.

Downloading a label through USB

Introduction

The labels can be designed with a PC based design tool or they can be designed on the control unit. The labels designed with a PC based design tool can be downloaded to the control unit by Ethernet or by USB thumbdrive. The labels downloaded thru USB thumbdrive will be stored in the label memory. The labels downloaded thru Ethernet will be stored in the printer memory, so they can not be reslected from the controller.



Beware:

Before a label be downloaded through a USB thumbdrive it needs to be printed to a Printfile (*.prn). It is not possible to download the original label file to the printer.

Installation of the driver

As soon as the compatible driver has been downloaded, it can be installed on the PC/Laptop which is going to control the printer(s).

To install the driver:

1. Unzip the downloaded file.
2. Start the installation by executing the program PrnInst.exe.
3. Click *Next* (Volgende).
4. Accept the conditions and click *Next*.
5. Select the desired printer and click *Next*.

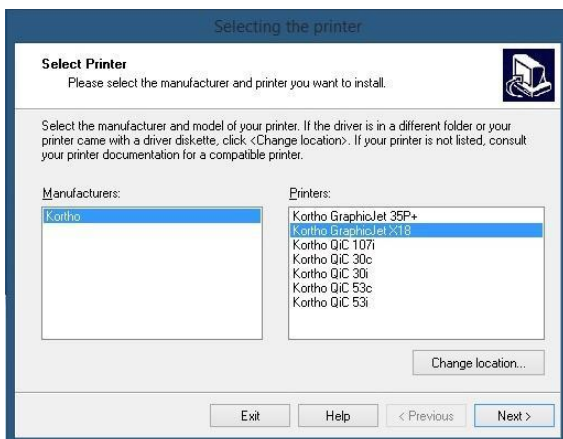

6. Select *FILE:*; change the printer name (optional) and click *Complete* (Voltoeien).

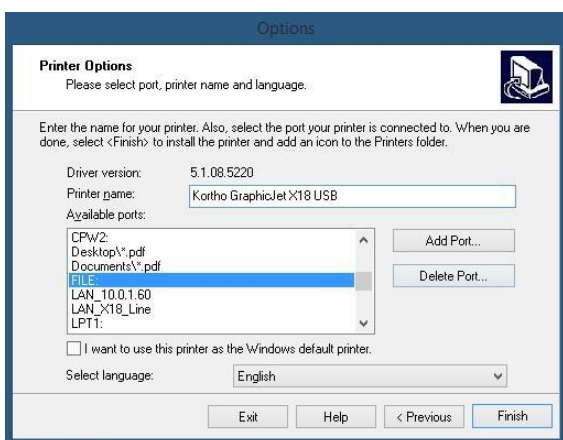

The driver is now installed on your PC/laptop and can be used to generate Printfiles.

Download a label through USB

To download a label by a USB thumbdrive:

1. Start NiceLabel and design a new label (or open an existing one – continue with step 4).



Beware:

To guarantee a good print result it is important that the label is designed for the printer to which one would like to download the label.

2. Select the right printer (driver configured to print to File as described above) and click *Finish*.

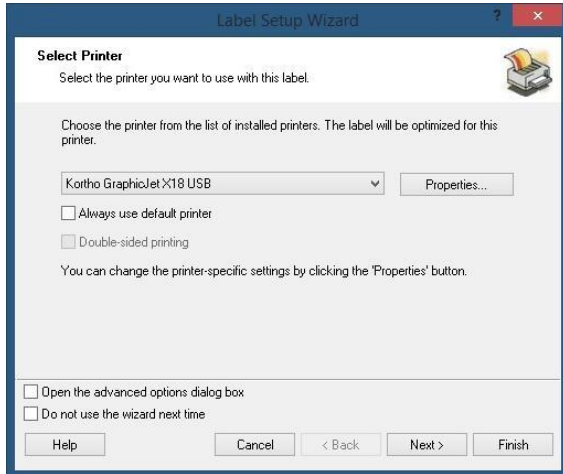

3. Save the new label design.
4. Insert a USB thumbdrive into the PC/laptop.
5. Select *File – Print* to print the label.

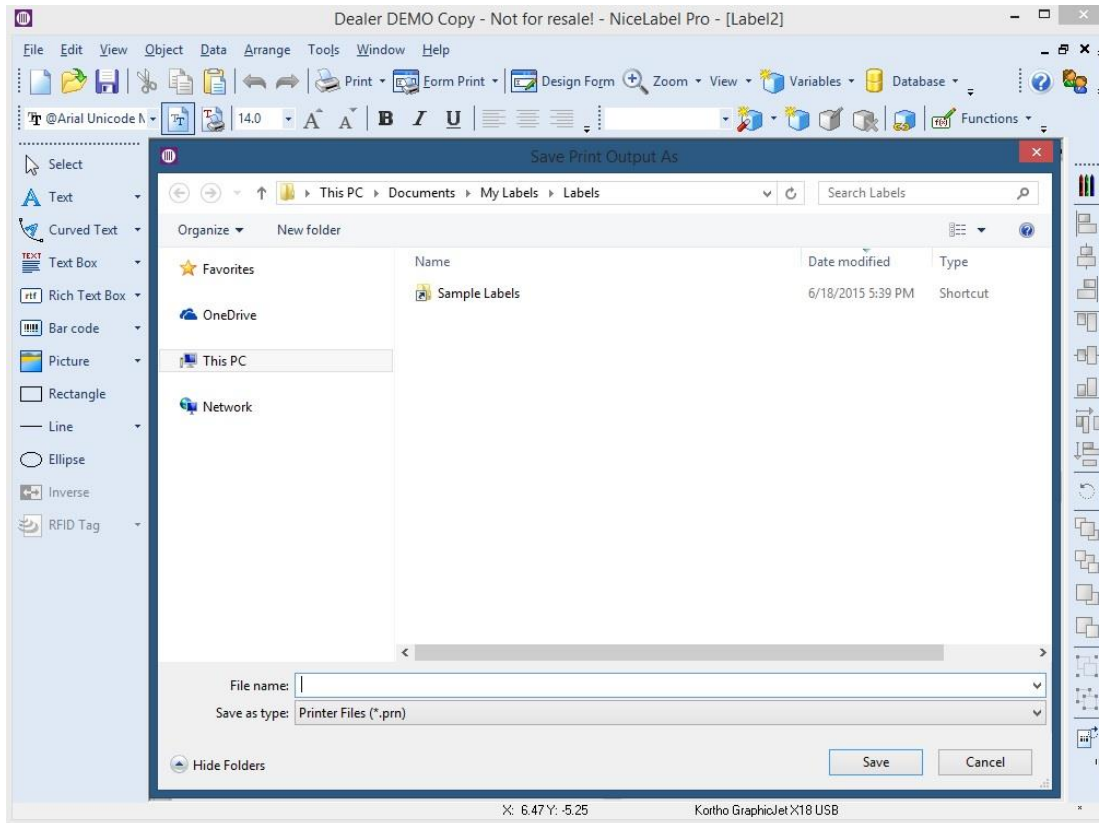

6. Choose the location of the USB thumbdrive to save the Printfile.

7. Give the Printfile a name including the extension prn, e.g. Testlabel.prn (preferably the same name as the Label name, in this way there is a clear relation between the Printfile (which cannot be edited) and the Labelfile (which can be edited)).
8. Click Save to save the Printfile on the USB thumbdrive.
9. Dismount the USB thumbdrive, so it can be safely removed from the PC/laptop.
10. Remove the USB thumbdrive.
11. Insert the USB thumbdrive into the control unit and wait for 4 seconds so it can be detected and mounted.
12. Copy the printfile on to the control unit by following the procedure as described in chapter 8.4.3.
13. Select the printfile for printing by following the procedure as described in chapter 8.4.1.

Sending a label on a network

Introduction

The labels can be designed with a PC based design tool or they can be designed on the control unit. The labels designed with a PC based design tool can be downloaded to the control unit by Ethernet or by USB thumbdrive. The labels downloaded thru a USB thumbdrive will be stored in the label memory. The labels downloaded thru Ethernet will be stored in the printer memory, so they can not be reslected from the controller..

Installation of the driver

Install the driver as described in Appendix E, Installation and configuration of the driver.

Sending a label on a network

To download a label through Ethernet:

1. Start NiceLabel and design a new label (or open an existing one – continue with step 4).
2. Select the right printer (driver configured to Port as described above) and click *Complete* (Voltooien).

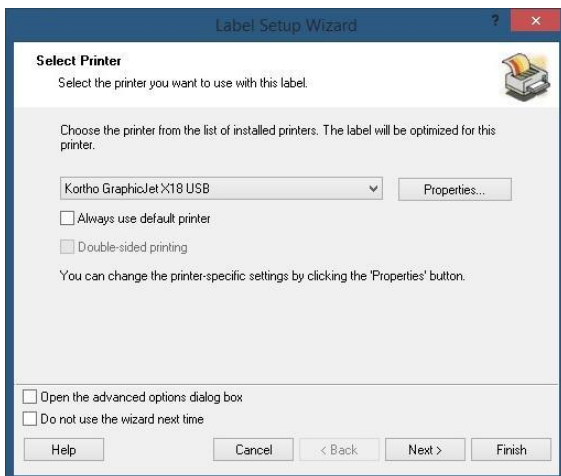

3. Save the new label design.
4. Select *File – Print* to print the label.



Beware:

To guarantee a good print result it is important that the label is designed for the printer to which one would like to download the label.

5. Select the amount of prints that need to be made.

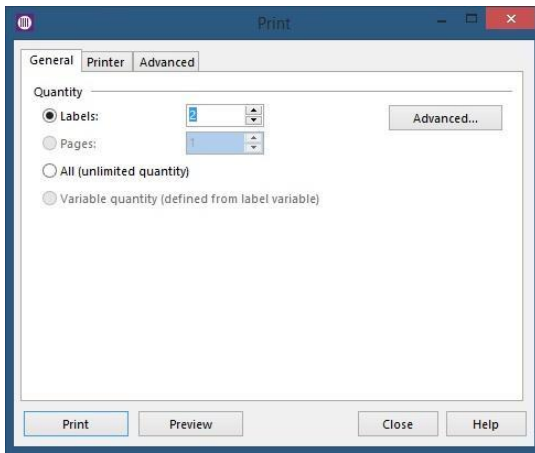

6. Select *Print* and the printer will start printing the selected label.

Menu Structure Tsc20

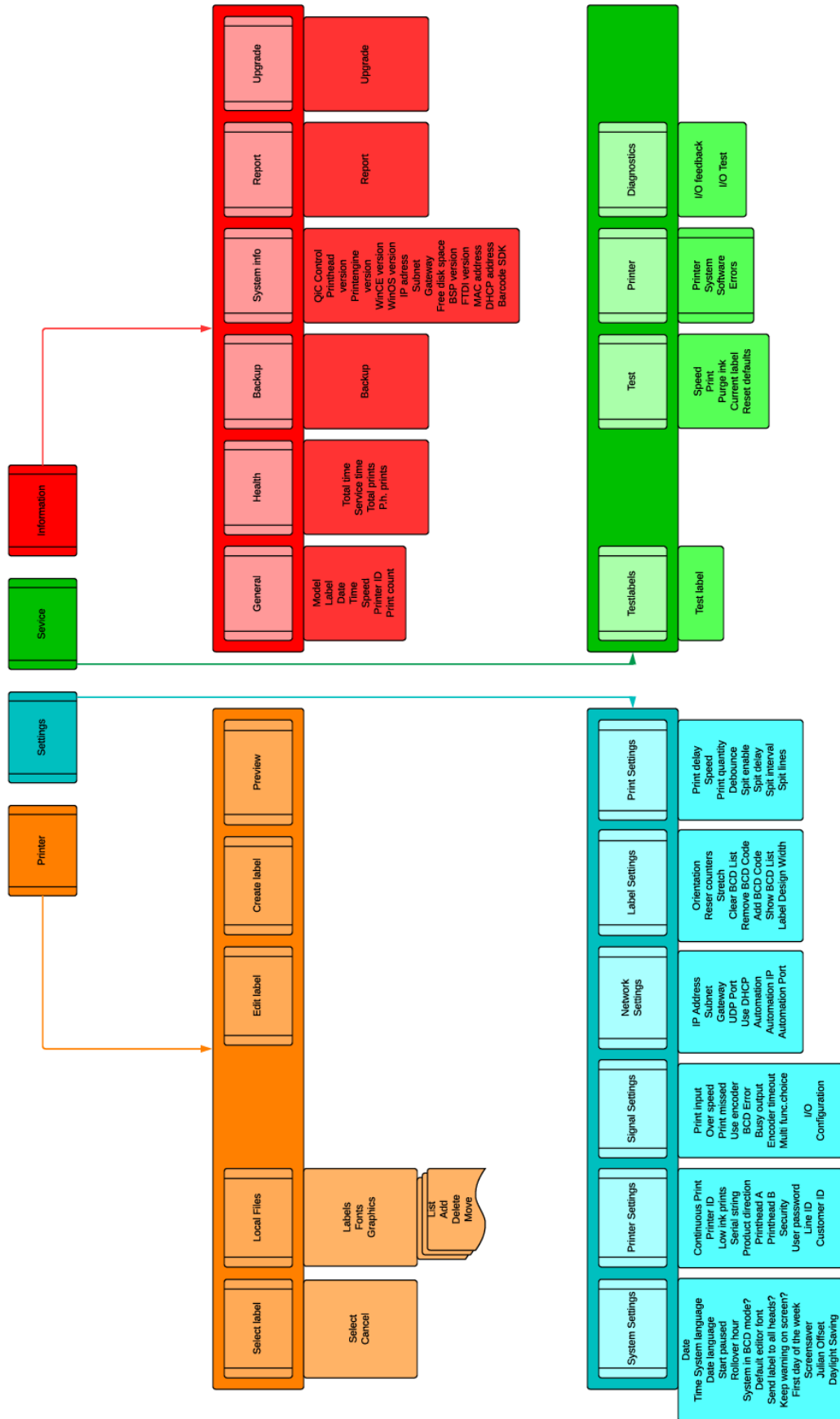

Appendix G Error list

The following errors / warnings can be generated by the system:

Error	Description
1	Flash programming error
2	Head not defined. Check Jumper setting J10 on headboard
3	Incorrect firmware for headboard (PIB) in coding unit detected??
4	A font in the label is not installed. Please install the font.
5	SREC File issue (PIB in coding unit)
6	Folder exists or cannot be made
7	The maximum storage space for a label is 112Kb. Reduce the file size.
8	The printer received an incomplete message. Try again.
9	The CRC check of the message is incorrect.
11	There is a problem with the Flash memory.
13	Unknown command received. Check the command or upgrade the firmware.
14	Minimum value is
15	Maximum value is
16	Missing value.
17	Maximum digits for
18	Maximum characters for
19	Date invalid.
20	Time invalid.
21	Wrong name or missing variable.
22	Door closed after timeout.
23	Maximum users.
24	Access Denied.
25	An unknown error occurred. Turn the printer off and back on after 10 seconds.
26	A problem occurred while generating the label. Try again.
27	Wrong coding unit connected. Connect the appropriate coding unit.
28	Font Error.
29	There is a problem with the font. Check Windows whether the font is correct.
33	A print is missed. The print request signal was received while printing.
35	A timeout occurred for the print-encoder.
40	Security disabled.

APPENDIX G, ERROR LIST

90	File system initialisation failed.
91	Ethernet initialisation failed.
92	No response from printhead.
93	Could not update printhead.
94	Could not download label to printhead.
95	Could not download font.
96	File not found.
98	Label area too large.
99	Print head has reset.
100	Could not download file.
101	Label contains no printable data.
102	There was a problem with RS232 printhead communications
103	BCD label list is empty
104	BCD label list is full
105	BCD Active, cannot load label
106	BCD label list is empty
107	Leaving BCD Mode. Select or send a label to continue printing
108	Automation connection failed
109	Mainboard DIP switch set, defaults restored
110	LAN Connection lost
111	USB Serial port detection failure. Please restart system
112	Ink data not correct for connected head
113	Printhead ink temperature too high

Error numbers which are not mentioned are reserved for other coding units.

Appendix H Using the BCD label selection

Introduction

Using BCD codes to select a label for printing has been around for quite a while and according to the questions we as Kortho have received from distributors, it is still actively used e.g. in the tile and wood industry.

BCD stands for Binary Coded Decimal. This is a method that uses the binary digits 0, which represents OFF and 1, which represents ON. Each digit of the number is encoded by a group of four bits which are a binary representation of the decimal number in question. Every digit is called a bit. Four bits are called a nibble. A Nibble is used to represent each decimal digit (0 to 9). The Tsc20 can receive a two decimal digit (1 - 99) so max two nibbles.

Decimal Digit	BCD Code			
	8	4	2	1
0				
1				■
2			■	
3			■	■
4		■		
5		■		■
6		■		
7		■	■	■
8	■			
9	■			■

When converting a decimal number to a BCD code, one has to convert an individual digit in a 4-bit format. See the picture. Black boxes are bits that are ON (1), white boxes are bits that are OFF (0). If for example the digit 7 will be transferred to BCD code this will be 8=off, 4=on, 2=on, 1=on, so this will be produced as 0111 ("0+4+2+1"). For a two decimal digit, i.e. 93, this will be 1001 0011 ("8+0+0+1" + "0+0+2+1").

The host, a system that outputs products that vary in composition constantly, generates a BCD code to indicate what product has been output. This BCD code can be used by the TSC20 to select a label that needs to be printed onto this product.

Usually, the variation in products is limited to 10 or 20 variants. So, the Tsc20 needs to have all the labels present on the system in order to print the correct label onto the correct product.

Generally, the printer is located further away on the production line because it simply cannot be installed directly at the location where the product leaves the host. In most cases, this means that there are a number of different products between host and printer.

This requires for the system to track which product needs to be printed with the required label. To solve this, a FIFO (First In First Out) print list is also implemented in the Tsc20 to be able to store the BCD codes generated by the host. This print list has a limit of 50 BCD codes.

Prerequisites.

In order to be able to use the BCD label selection feature, one requires the Tsc20 DUO controller (art. nr. 818131). This controller has the BCD hardware fitted on the CPU board. The BCD input is a 15-way SUB-D connector, X07, located on the connector plate at the bottom of the controller.

Also, the hardware for the product detect input is fitted on the CPU board which allows one to detect the product at the moment the host has created a valid BCD code. This product detect input is available through connector X08 on the connector plate.

Selecting a label through BCD is available since version 1.0-16032016a.

Label name requirements for BCD selection

In order for labels to be selected by a BCD code, the names of the labels need to conform to the following naming convention. The user is required to give the labels a name that corresponds with the BCD code that is generated by the host in order to print the correct label on the product.

This is done by giving the labels the following names: BCD_XX_Y.ZZZ

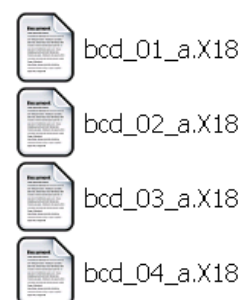

Where XX represents a number between 01- 99, the product BCD code and Y represents the connected head. In a one-headed system, this is always A and in a duo-headed system, this is A for head 1 or B for head 2.

ZZZ represents the file extension that can be used: X18, X54, X72, PRN, PNL or QDL The system scans for such a label name as soon as the BCD code is used to select a label. It will scan according to the priority as mentioned above (first X18, then X54, etc)

Make sure that all the labels required are present on the system. If the system uses a BCD code and the label is not found, an error message (error 96) will be displayed to indicate that the label has not been found. The system will not make a print on the product and will load the next label in printlist to be printed on the next product. This way all codes will remain in sync despite one product has not been coded.

Label selection using BCD codes

From version 05122018a it is possible to select the folder from which the BCD labels are selected. This means that one can have multiple folders with BCD labels. To select the folder that is used for selecting the BCD labels, set the system to BCD mode. (Settings-System). The Select Label button in the main menu will now change to Select BCD Folder. Press it and select a folder in the top area and press Ok.

To see which folder has been selected for BCD labels, press Info – general. If nothing is shown behind BCD Folder, the root folder is used.

The printlist in the TsC20 has a maximum size of 50 BCD codes, which should be enough for any application using BCD label selection.

The TsC20 needs to be told when a product leaves the host and when the associated BCD code for this product is generated by the host. This can be implemented in various ways and depends on how the host has implemented this. Since this depends on the host and can therefore be different each time, a method has been introduced that offers flexibility. The TsC20 has an input, product detect - X08 -, which needs to be activated, indicating that the BCD code on the BCD input is valid. This signal can be applied by the host or one can connect a sensor, such as a photocell, to detect the product at the moment that the BCD code for that product has been generated by the host. The BCD code enters the FIFO. When a product is near the printer and is detected by the print request sensor - X04 -, the correct label is printed on the product and the BCD code used to choose this label will be removed from the FIFO. Then the next BCD code in the FIFO is used to select the label which needs to be printed on the next product.

Activate the BCD mode

The source of the label that has to be printed can be different;

1. Selected on the controller (X18, X54, X72, PRN, PNL or QDL)
2. Send down by Nicelabel over LAN,
3. Send by Kortho Control Center over LAN
4. Selected by a BCD code.

To select labels using a BCD code, the system needs to be put in the so-called BCD-mode. In this mode, the system will prevent selection of labels on the controller. Sending down a label through LAN is currently not restricted, so be aware that sending labels through, LAN when in BCD mode, will cause products to be printed with the wrong label.

To activate the BCD mode, go to Settings -> System -> System in BCD mode -> Yes

Now the system is ready to receive BCD codes.



See also Trouble shooter, error 105.

BCD functions

Basically, BCD codes are pushed into the back of a list and removed from this list at the front when the label that corresponds with the BCD code is printed.

Due to unforeseen issues, there might be a need to manually edit this BCD list for whatever reason. The TsC20 allows one to perform some basic editing on the list. This is useful for testing, but also for viewing the list and altering the list if required.

To edit or view the BCD list the operator can navigate to Settings -> Label. When interruptions during the production process appear the operator can check and modify the BCD print list.

Reset BCD

Pushing this button will immediately empty the printlist. So all the previously received BCD codes will be removed and nothing remains in the print memory anymore.

This is the same as switching the TsC20 controller on when the BCD mode has been activated. The list is cleared and no label is loaded.

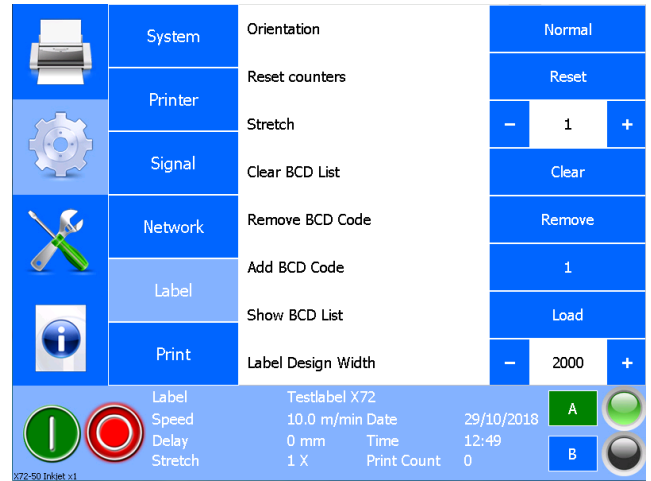

Remove BCD

The Remove BCD function deletes the first received BCD code. It is possible to use this function repetitiously until the list is empty.

Push BCD label

If, for whatever reason, a BCD code has to be added to the print list by hand, the operator can do this by easily entering the BCD code. The code will be inserted at the end of the list.

Show BCD list

To check what is in the print list, the operator can check this by pushing on Load. On the right is the first label that will be printed. On the left is the last label that will be printed.

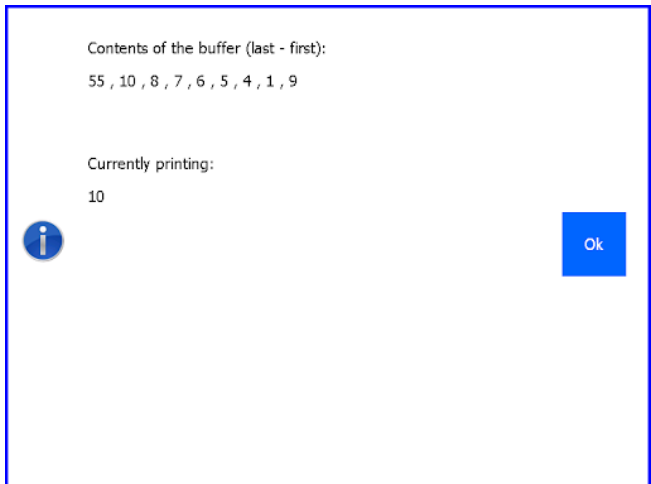

BCD empty error action

When the printlist has no BCD code stored, but the control unit still receives print requests the operator can set the type of notification. In menu Settings -> Signal one can find the setting BCD empty error action. The operator can set this to Warning or Error. If Warning is activated the operator gets a message on the TsC20 screen. If Error is activated the operator gets a message on the TsC20 screen and the General Error output will be activated.

Required connections for BCD label selection

All the connections of the I/O can be found in Appendix D. Below the locations of X07, BCD input, and X08, Product detect, which are required inputs for BCD operation.



BCD-input

This is input X07. The BCD code that's generated by the host machine must be applied to this connector. For the schematics of connector X07 see appendix A.

Use a shielded cable that is not longer than 30 meters. Make sure the cable is clear from "noisy" cables and other noise generating equipment.

Using the BCD input, it's possible to select from 99 different labels. The inputs A1, A2, A4 and A8 are used to make up the BCD code for the single units and B1, B2, B4 and B8 are used to make up the decades. BCD code `00` is prohibited.

Product detect

If the Product Detect input X08 is activated, the currently active BCD code on the input X07 will be stored in the print list. It is very important that the Product Detect input is activated by the host or the actual product, when the BCD code indicating which label needs to be printed on that product, is valid. The Product Detect input has the same configuration as the Print Request input. See appendix B to determine how to connect a sensor or switch to X08.

Print request

X04 (Photocell) or X03 (I/O). If the actual BCD label has to be printed, a print request can be applied to one of these ports. Use either the print request input on X04 OR on X03, but not both. The print request can be generated by the host or by e.g. a photocell which detects the product at the correct moment (when a valid BCD code is present).

How it should work.

After making the connections to the TsC20, it's time to test the setup.

1. The host machine outputs the BCD code.
2. A product detect is generated. This can be generated by a photocell or by the host machine. When a product detect is generated the BCD code from step 1 will be stored in the print list.
3. Print request will activate the print head to print the label set by the BCD code

Troubleshooter

We will give an enumeration of the possible errors you can encounter, related specially to BCD mode.

Error 96 - File not found

This error occurs if a BCD code in the list does not exist in a label name. This means the label is missing or a wrong name is used and this error pops up to notify the the operator. The code is stored in the printlist. The popup also shows which BCD code caused the error. If more than one BCD codes are not found, only the first BCD code is displayed on screen. The process doesn't stop on this message. So, the next BCD code in the

list will be handled by the system. Also new BCD codes which are sent by the host will be received and stored in the printlist.

Error 103 - BCD label list is empty

When the printlist has no BCD codes stored, and the TsC20 is still receiving print requests this error pops up. Recommended setting is error in menu Settings -> Signal -> BCD empty error action. The general error relay will be activated.

Error 104 - BCD label list is full

The list in the TsC20 has a maximum size of 50 BCD codes, which should be enough for any application using BCD label selection. When sending the 51th BCD code to the printer list the TsC20 will respond with error 104. Also this BCD code will be ignored.

Error 105 - BCD active, cannot load label

If the BCD mode is activated it is not allowed for the operator to select labels. If the operator tries to do this, anyway, the control unit responds with error 105.

Warning 106 - BCD label list is empty

When the printlist has no BCD code stored, and the control unit still receives print requests this error pops up. If this happens in the middle of a production process, the operator has to check the communication started at the host side (where the BCD is generated) to the printer control unit. In the menu Settings -> Signal is the function "BCD Empty error action" set to warning. The operator should get a notification on the screen of the TsC20 control unit. The system will continue using the BCD codes, but be aware of the fact that synchronization is now lost. Meaning, the labels are not printed on the correct products anymore. Recommended setting is error in menu Settings -> Signal -> BCD empty error action



Be aware!!

In run mode (green button is activated) the TsC20 will add the BCD codes to the list and will process them. If the control unit is set to pause mode (red button is activated) by the operator, the TsC20 will not store BCD codes to the list nor will it remove BCD codes from the list.

Appendix I Using variables in labels

Variables in labels

From software version V1.0-19032018a onwards, the TsC20 now supports the use of variables. Variables in the software here are actually items that require to be defined and given a name. Defining variables is the same as creating an item. The difference is that the item will not be placed on the canvas but is stored inside the label and can be referenced using a name that the user can assign to the variable.

The variable is therefore actually a predefined item which is given a name. The variables can be used for:

- Creating a composite Text item consisting of one or more variables,
- Creating a composite barcode item consisting of one or more variables. Currently the following barcodes support variables:
 - QR-code,
 - GS1-128,
 - Code 128 and
 - Data Matrix

Variables can be defined for the following items:

- Text,
- Date,
- Time,
- Counter (also operator input is supported),
- ID (Printer ID, Customer ID and Line ID) and
- Shift Code

Date, time, counter and shift code are so-called autocodes, meaning they are updated after a certain event. Being able to create a composite text or barcode item therefore means that this composite item is also updated if such a variable is used. A few examples:

- A barcode that contains a date variable will be updated when the date changes
- A barcode is updated after each print when a counter variable is included in the barcode data
- Etc etc

Variables are not stored globally in the controller, but locally inside the label file.

Adding / defining variables to the label

The suggested workflow is to think about how a label needs to be composed:

- Which items are fixed text items, auto codes or graphics in the label,
- How many composite items are required,
- What types of composite items are required (composite text and / or barcode(s))
- What kind of information should be present in the composite item

Once the requirements for the label have been defined, go to the controller and create it (Later in 2018, we will also introduce Kortho Control Center, a Windows software package that will also allow you to create and manage labels on a Windows 10 PC / laptop / tablet for each X-series printer in a network)

Access to adding, editing and removing variables and creating composite texts and barcodes is done in the label editor. In the top tool bar there is a button indicated by "VAR":



Press "VAR" to see the following screen containing these buttons:



- To Add a variable to the label press the "+" button
- To Edit a variable, press the "pencil" button
- To Delete a variable from the label, press the "bin" button. When a variable is currently in use in a composite text or barcode, the variables are coloured red and cannot be deleted.
- To Create a composite text item, select the "ABC" button (variables need to be made first of course)
- To Create a composite barcode, select the "barcode" button (variables need to be made first of course)

There is no option here to edit or delete a composite item. Once a composite item has been created, it will be visible on the canvas of the label editor. If a composite item has been created, use the standard toolbars to manipulate the item, including deleting (bin) and editing (pencil).

Defining and adding a variable is simple, select the "+" button and select which type of variable is required. The system will also list which variables have already been defined by name. When the type of variable has been pressed, one will get the screen on which one should add the variable name and set its properties. Just like when adding a normal item. Use a variable name that makes sense for future editing.

When saving the label, the variables are saved inside the label file. This means that this label with its variables can also be used on other system without defining the variables again. Of course, the software running on the systems needs to be V1.0-19032018a or higher to support variables.

Creating a composite text item

Once the required variables have been defined, one can use these to create a composite text item.

To create a composite text item, press the "ABC" button. When pressed, one will be presented with the options for the composite text item. Most are known from the "standard" text item.

- Font; select the font type to be used for the composite text item,
- Select Bold, Italic, Underline or a combination thereof if required,
- Select the variables that make will make up the composite text item.

Below the settings, there are two columns. The variables that can be used to make up the composite text are listed in the left hand column. The variables selected to make up the composite text item are shown in the right hand column. It is possible to use a variable multiple times in the composite text item. One could define a separator that can be used multiple times for instance.

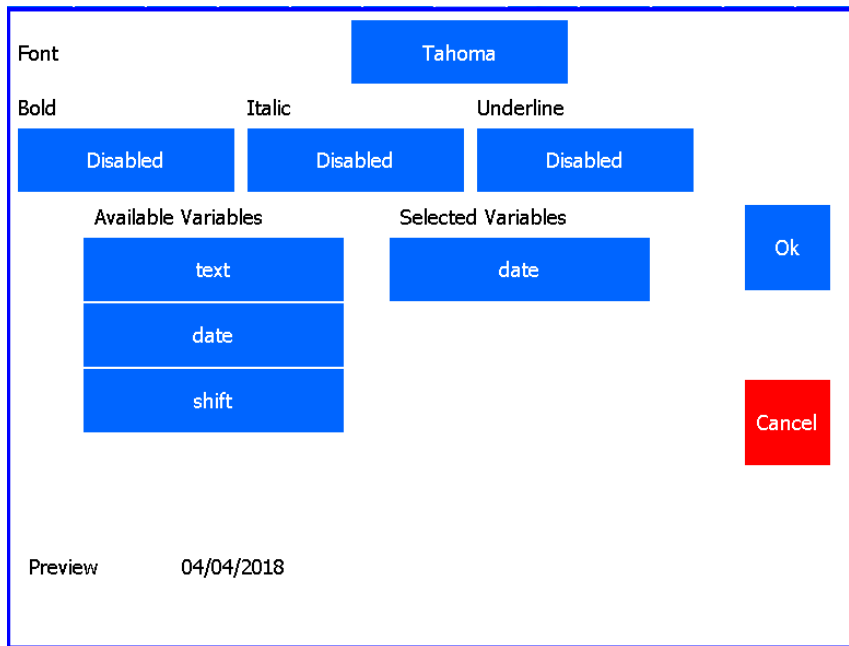

Pressing on the variable in the left hand column will make it appear in the right hand column. The top variable is the most left one in the composite text. If a variable needs to be deleted from the composite text, press on it in the in the right hand column. To reorder the variables, simply delete them from the right hand column and select the required order by selecting variables in the left hand column.

At the bottom of this window, one will see a preview of the composite text item. Press Ok to confirm the creation of the composite barcode and to view it on the design canvas.

To edit the composite barcode, select it as any other item and press the “pencil” button.

Creating a composite barcode item

Once the required variables have been defined, one can use these to create a composite barcode item.

To create a composite barcode item, press the “barcode symbol” button. When pressed, one will be presented with the options for the composite barcode item. Most are known from the “standard” barcode item.

- Type; select the barcode type to be used. Currently QR, GS1-128, Code 128 and Data matrix can be selected,
- Human readable; select whether human readable should be part of the barcode. Barcodes that do not support Human Readable will ignore this option. (QR-code and Data Matrix in this case)
- Module width (px); use the module width to increase the size of the barcode. The QR-code and Data Matrix require at least a module width of 5 to be readable. The GS1-128 and Code 128 should be set to 3 as a minimum to be readable.
- Barcode height; here one can determine the height of the barcode in mm for the GS1-128 and Code 128 barcodes. The height of the QR-code and Data Matrix depend on content and Module Width setting.
- Font; the font type to be used for the Human Readable if supported by the barcode symbology.

Type	QR
Human readable	Disabled
Module width(px)	2
Barcode height (mm)	30
Font	Arial
<input type="button" value="Ok"/>	
<input type="button" value="Cancel"/>	
Available Variables	
<input type="button" value="text"/>	
<input type="button" value="date"/>	
<input type="button" value="shift"/>	
Selected Variables	

Below the settings, there are two columns. The variables that can be used to make up the composite barcode are listed in the left hand column. The variables selected to make up the composite barcode item are shown in the right hand column. It is possible to use a variable multiple times in the composite barcode item. Pressing on the variable in the left hand column will make it appear in the right hand column. The top variable is the most left one in the composite barcode. If a variable needs to be deleted from the composite barcode, press on it in the in the right hand column. To reorder the variables, simply delete them from the right hand column and select the required order by selecting variables in the left hand column.

There is no preview of the barcode in this window. Press Ok to confirm the creation of the composite barcode and to view it on the design canvas. To edit the composite barcode, select it as any other item and press the “pencil” button.

Sample of entering variables.

Select the VAR button to enter the variables menu.

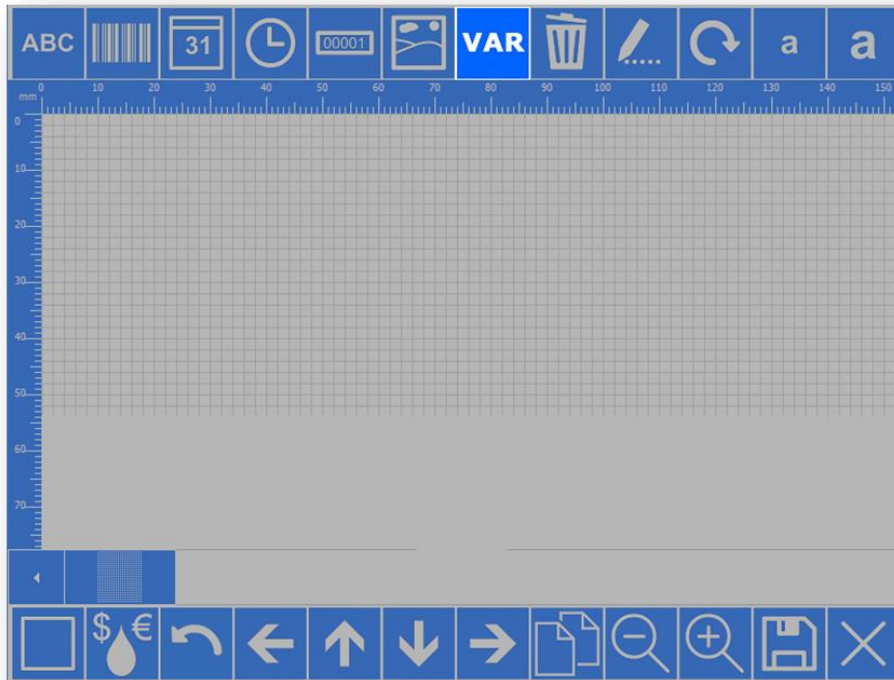

In the variables menu, there are 5 buttons. Add, Edit, Delete, create Text and create Barcode. Select the Add button to create a variable.

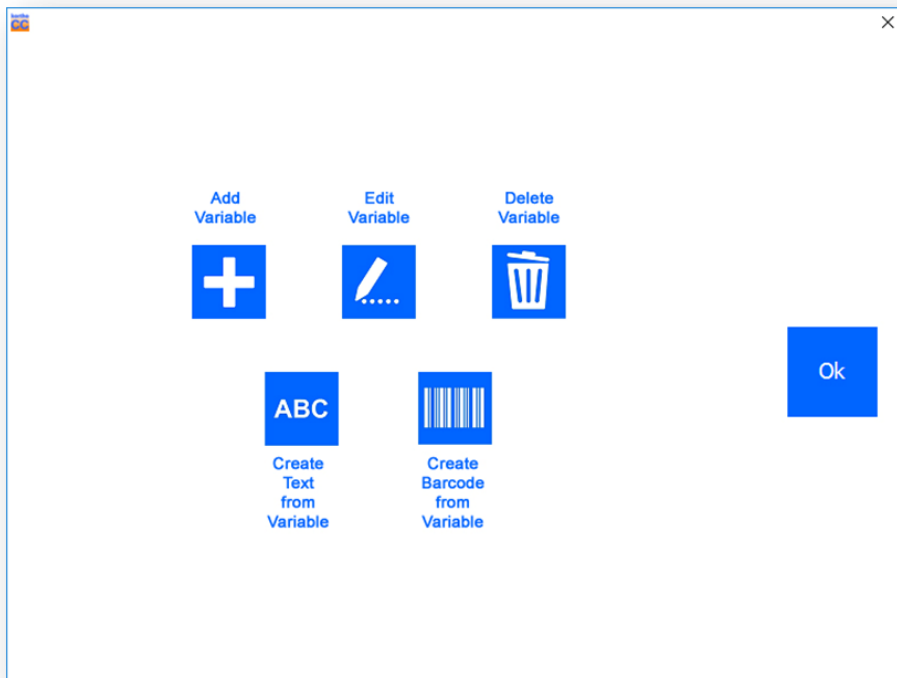

APPENDIX I, USING VARIABLES IN LABELS

On the left side of the screen are the current variables displayed. In this case, the variable list is empty. On the right side, the type of variables is displayed. Select the Text button to add a variable text.

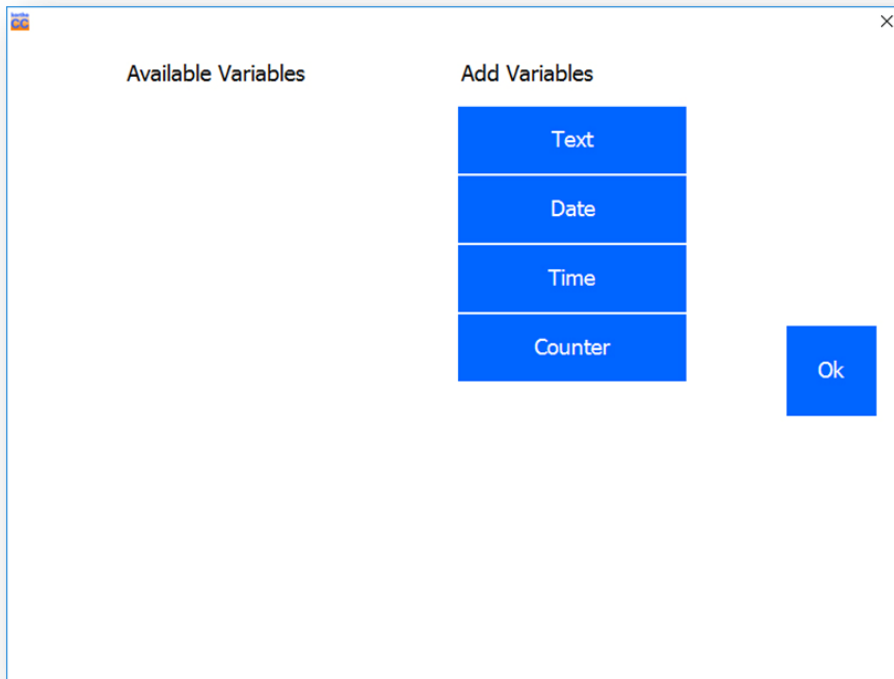

First we enter the variable name. This helps to create the variable Text or Barcode later in the process.

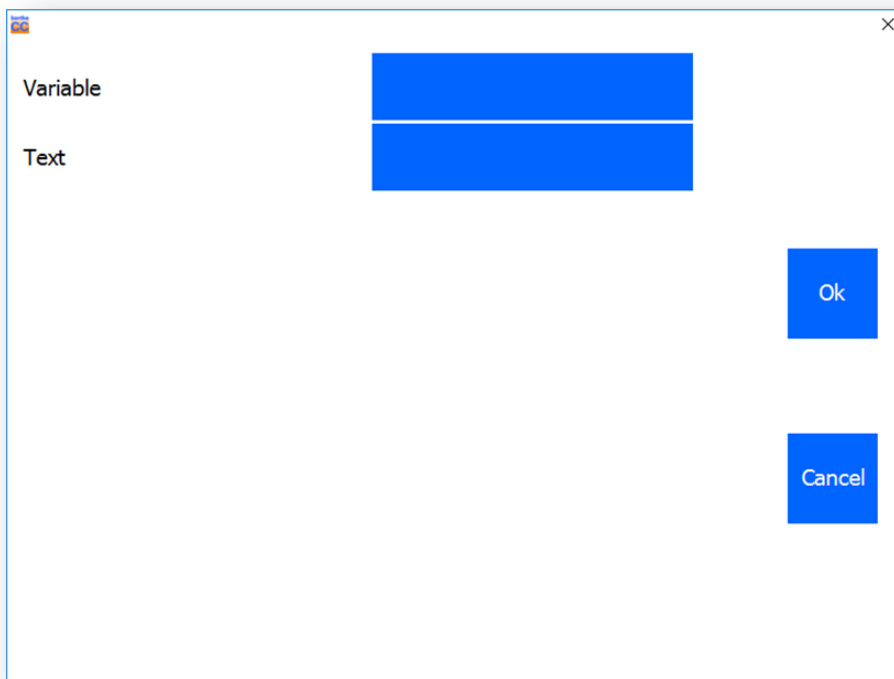

In this case, the variable name is Line_number. The content of the Text Variable is set to L01. Select OK to add the variable.

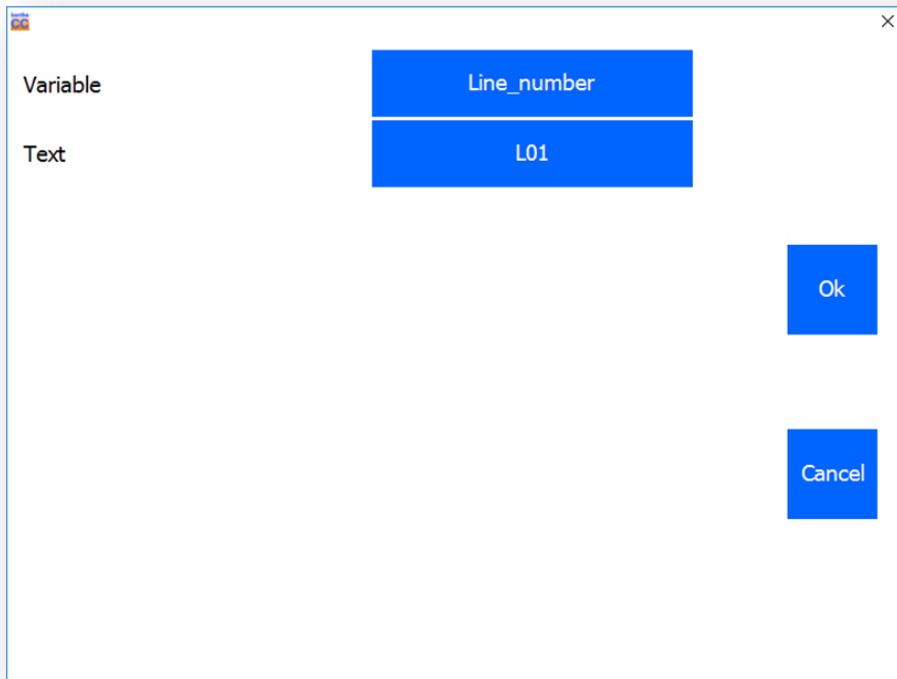

The variable will appear in the variable list on the left. Now select Date to create a Date Variable.

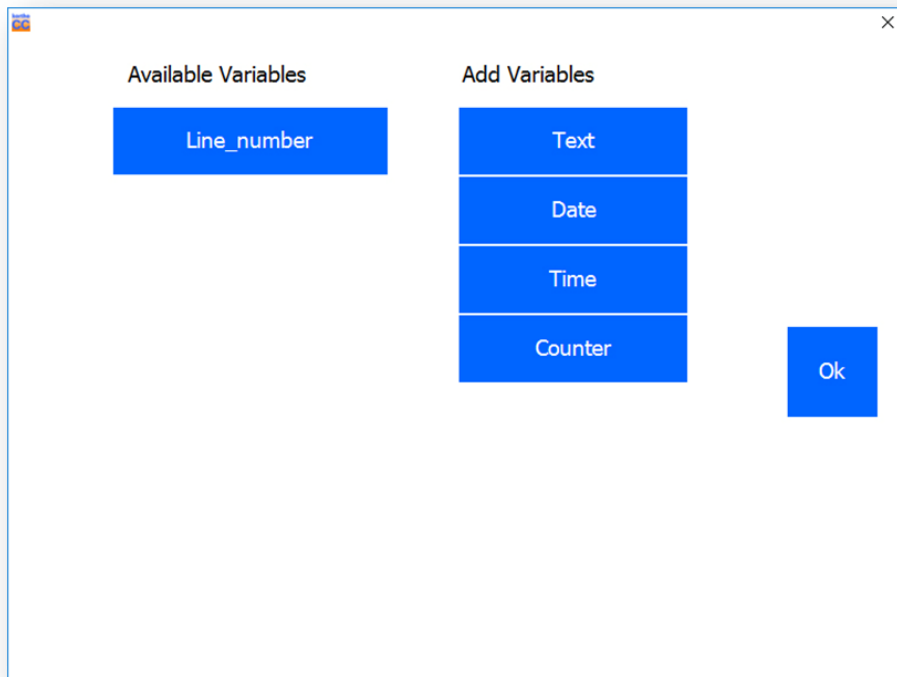

In this case we entered production_date as the variable name. The content of the Date Variable is set to Day, Month and Year (2 digits). Select OK to add the variable

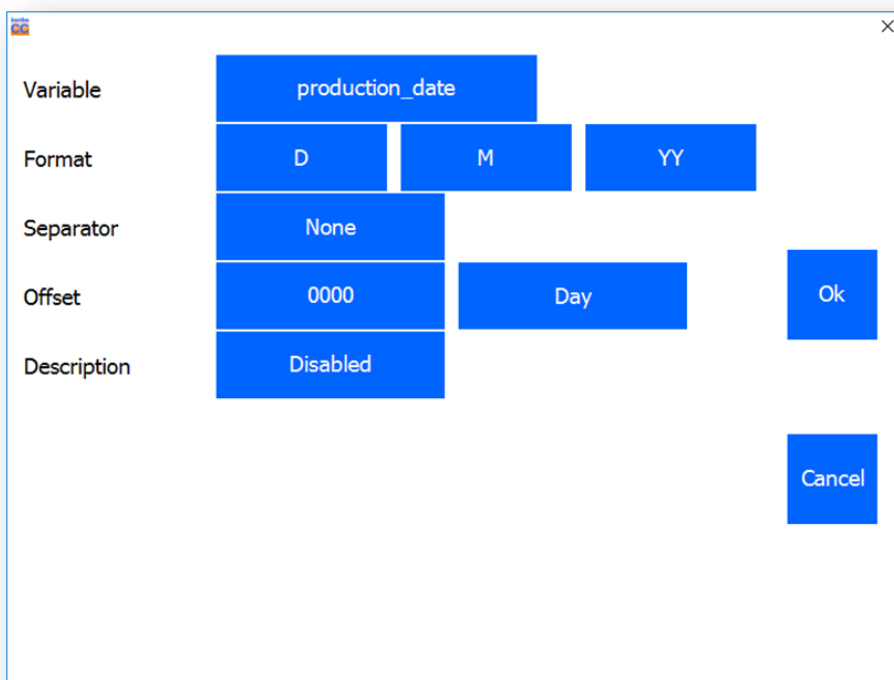

Now select Time to create a Time Variable. In this case we entered current_time as the variable name. The content of the Time Variable is set to a 24 hour clock. Select OK to add the variable

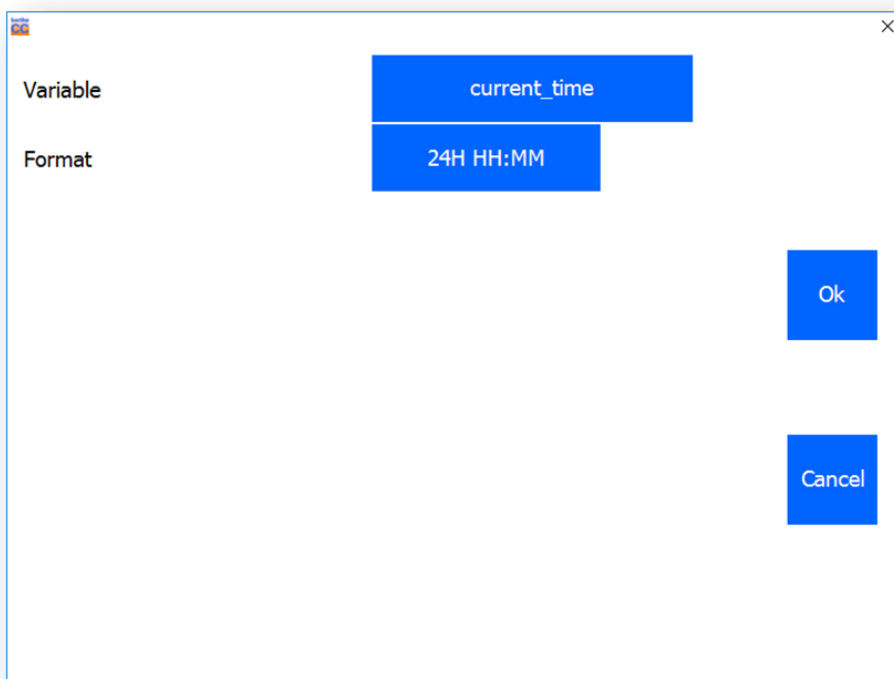

Now select counter to create a Counter Variable. In this case we entered box_counter as the variable name. The content of the Time Variable is set to a regular counter that resets after 99999 boxes. Select OK to add the variable

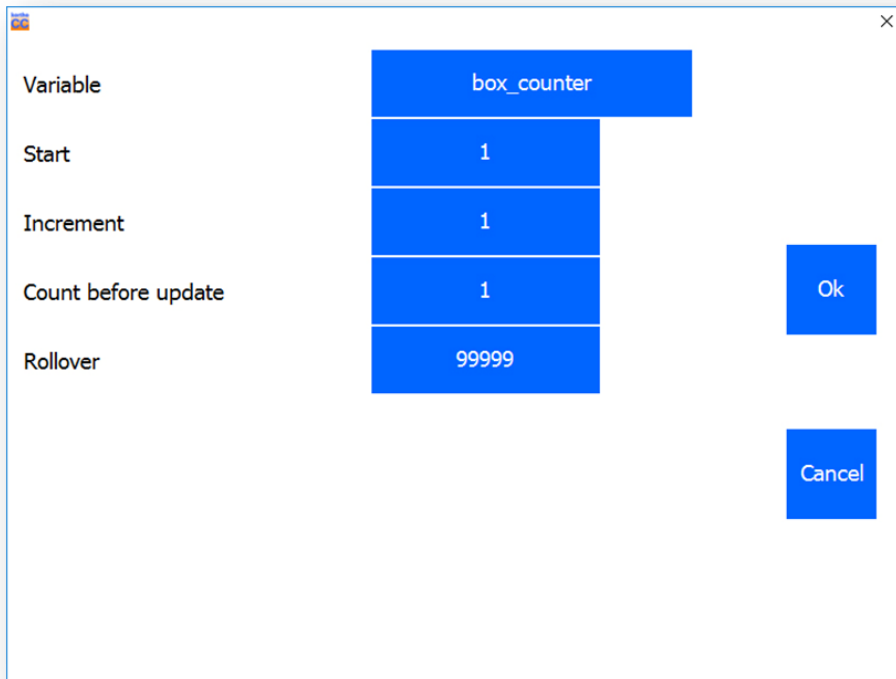

All the variables are set and appear in the variable list on the left.
Select Ok to go back to the variables main menu.

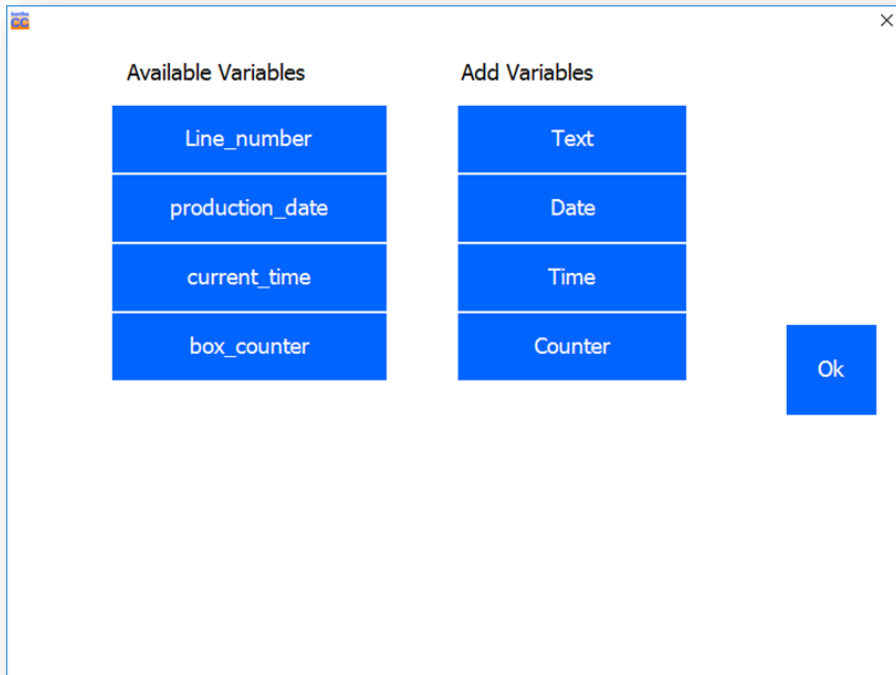

Select the Text button "ABC" to add a text with variable data.

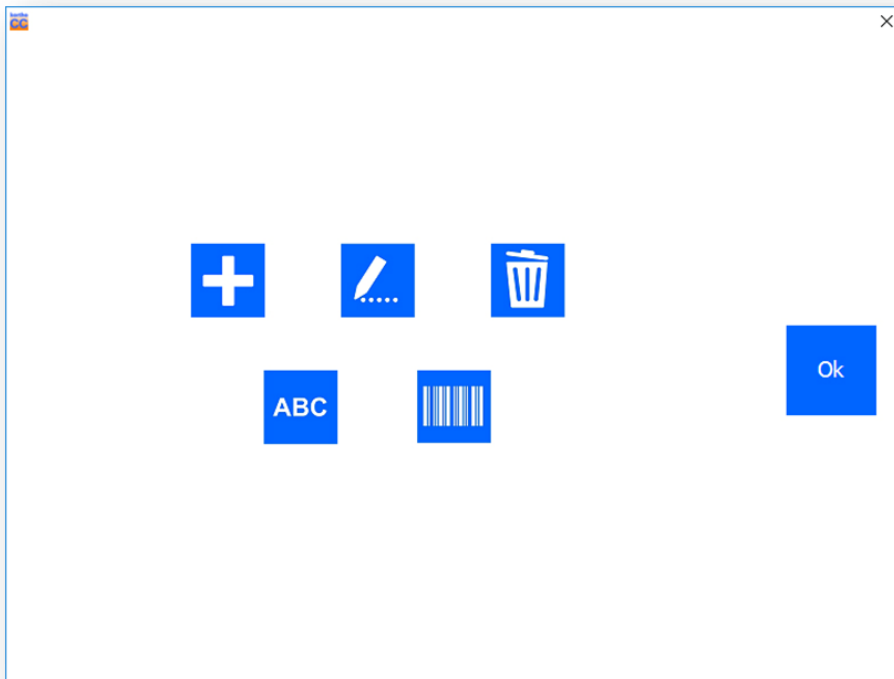

There will be a list with the available variables on the left side of the screen. Select the variables that will be used in the order that they need to appear.

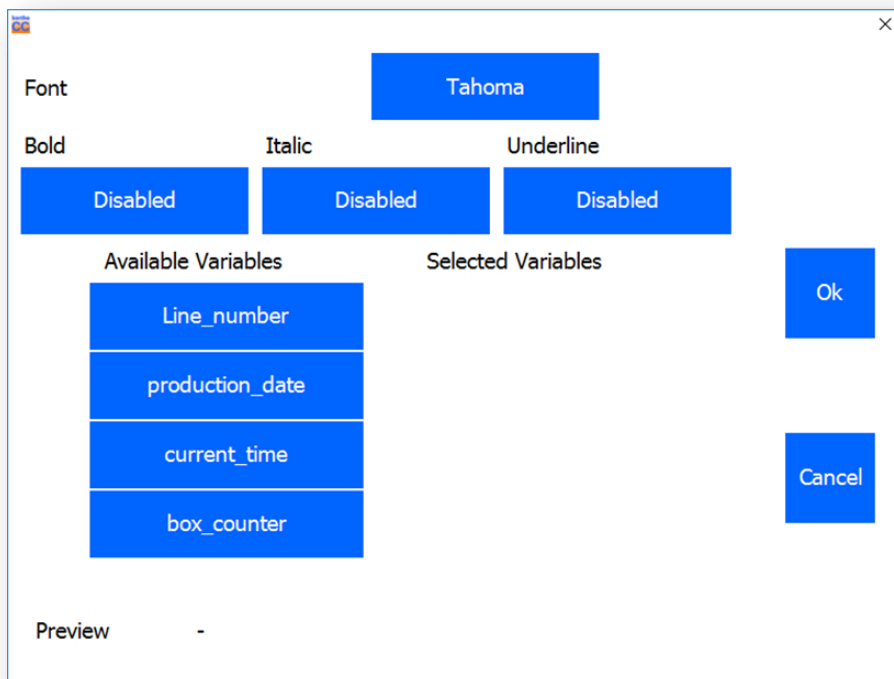

In this case, the order of the variable data is set to production_date, current_time, Line_number and box_counter. A preview of the complete string is displayed in the bottom of the screen.

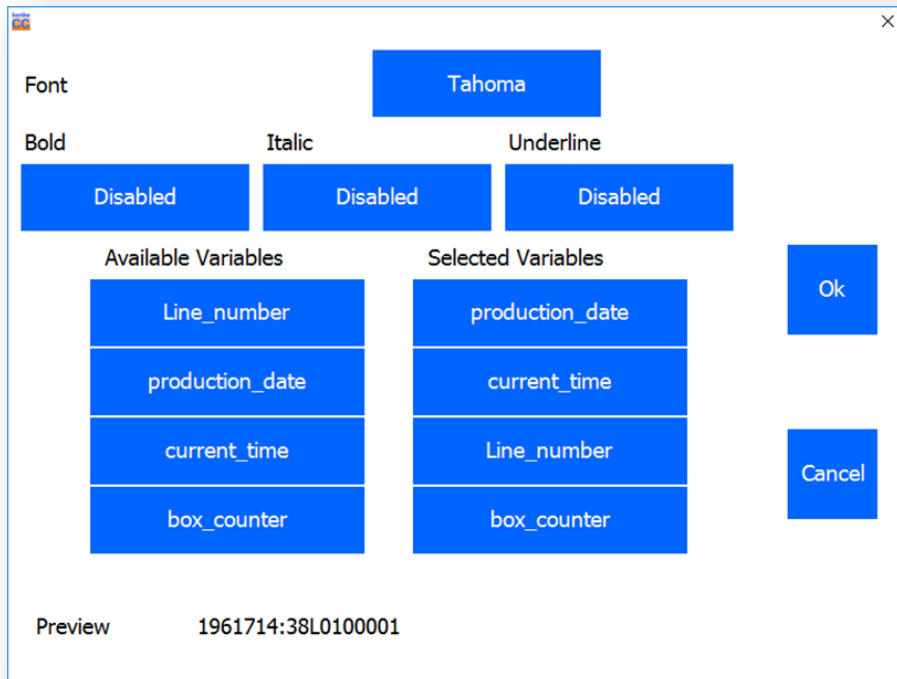

Select Ok to add the variable text item to the label

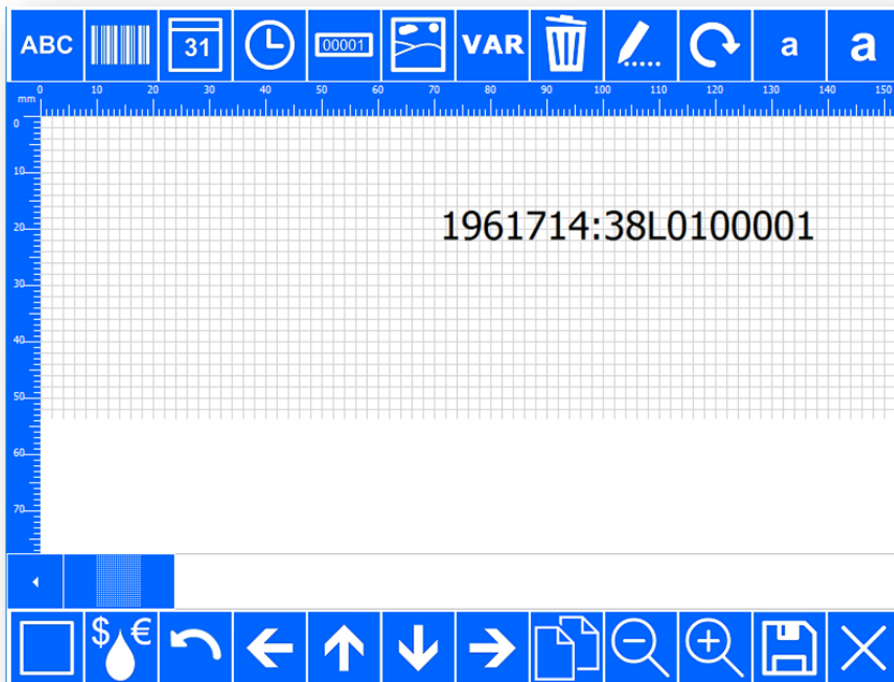

End of example.

Appendix J Setting and using the security option

To prevent unauthorized people from accessing the settings in the TsC20 controller, a security option has been provided for.

The system uses two passwords, a fixed system password (cannot be changed) and a user password can be changed).

When the security feature is activated, the screensaver is automatically set to 10 minutes. As long as the screensaver is inactive, the system can be accessed without entering the user password. To make sure the TsC20 is secured directly after the user has accessed the system, there is a button in the top right of the display called "Lock screen". Touching this button will lock the system manually.

Setting up the security option requires following these two steps sequentially:

1. Set the user password (system password required)
2. Enable the security option

To set the user password, go to the Settings – Printer page:

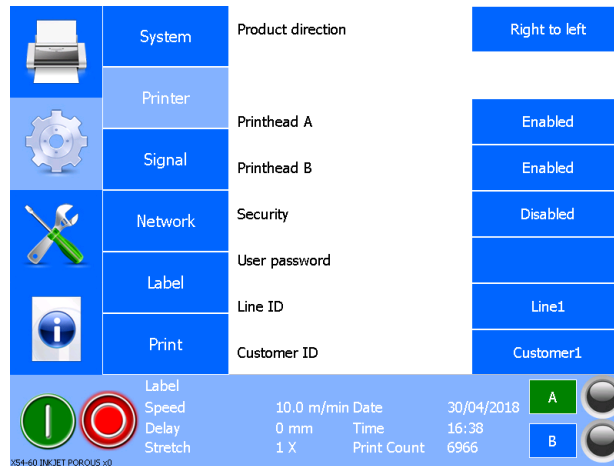

Select the empty field behind User password. In the next window, enter the system password

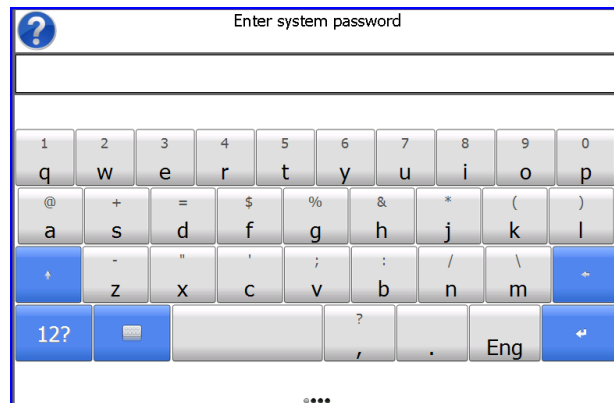

After entering the system password, you will be asked to enter a user password:

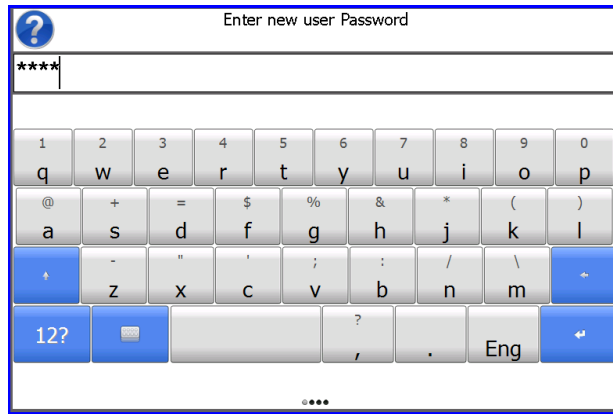

When entering the user password, the characters one enters will be shown as asterisk characters (*). Be careful when entering the characters.

After entering the password, press the enter key. The system will ask you to reenter the password:

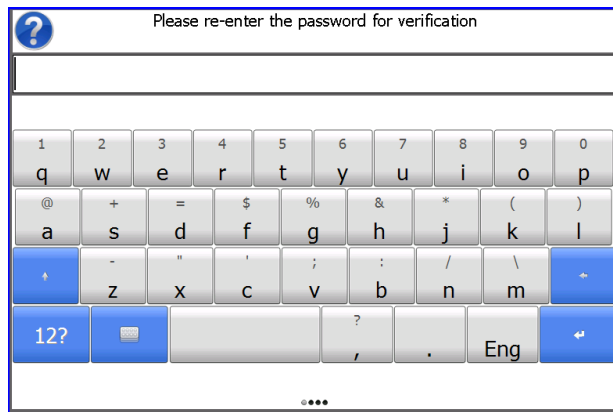

If you entered the user password correctly, the previous menu will be shown.

Next, enable the security option. You will be asked to enter the system password to activate the security option.

Turn off the controller and switch it back on after 10 seconds. When the controller has booted, one will see the lock screen:



When the screen is touched, you will be asked to enter the user password. If you enter the correct user password, the main screen will be shown. Also notice the extra button in the top right of the screen:

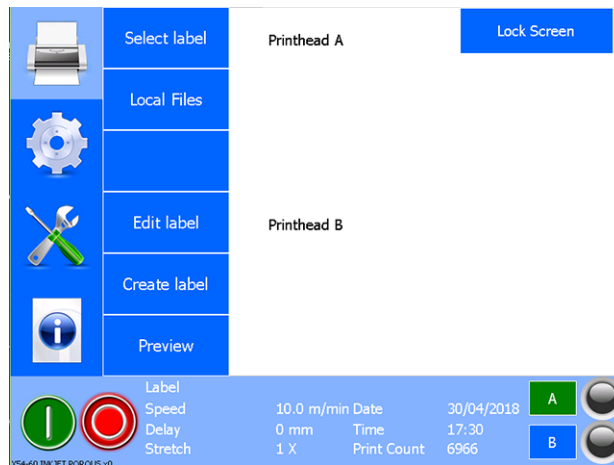

To lock the system straight away instead of waiting for 10 minutes to lock automatically, press the Lock screen button.

When the security is disabled, the user password is also cleared. So, when activating the security, one also needs to set the user password again.

The system password can be requested from Korthofah bv (or distributor).

Appendix K Restore factory settings using dipswitch

In rare occasions, when nothing else will help, it is possible to reset the controller back to the default factory settings. This can be done in two ways:

- Use the function accessible through the menu Service – Test – Reset to defaults,
- By setting dipswitch 4 of SW2 on the controller PCB to ON.

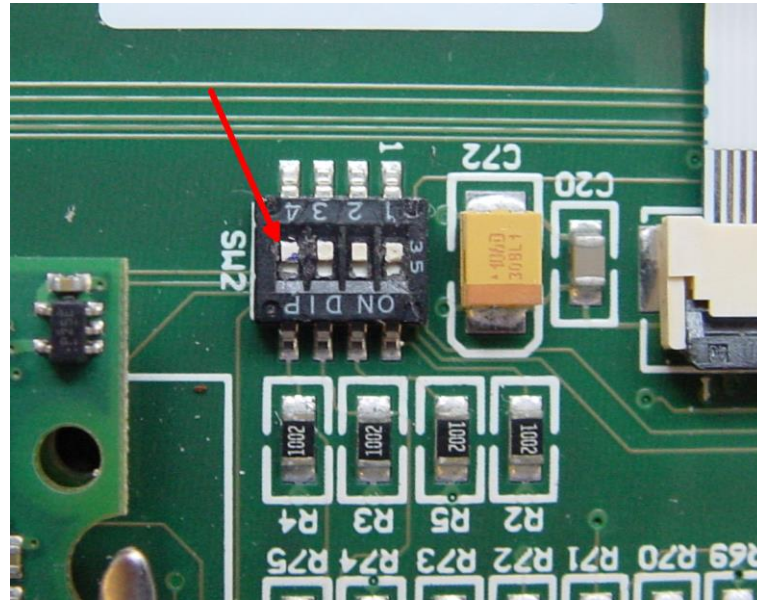

If for any reason it is not possible to use the software option to default the controller, it is possible to do it by setting a dipswitch 4 of SW2 to the ON position and switch the controller on. Once the controller has booted, it will show a warning that the system has been reset to the default factory settings. Once the system is running, do not forget to switch the system off and slide dipswitch 4 back to the OFF position again!

Appendix L The automation feature

For automation purposes, we received requests asking us to make it possible for the system to send a message over TCP/IP to a specific IP address and port number after a label has been printed. We have added new network enabled functionality so the print system can even be more tightly integrated into existing and newly developed packaging and automation applications. The message that the controller will send after each print is "PRINT_COMPLETE" (ASCII, capital letters).

The main purpose of this feature, but not restricted to, is to use this in combination with the Nicelabel automation feature. NiceLabel Automation is an application that automates repetitive tasks. In most cases one would use it to integrate label printing processes into existing informational systems, such as existing business applications, production and packaging lines, distribution systems, supply chains.

To setup the controller to send a PRINT_COMPLETE after a label has been printed is, again, very simple. Press Settings – Network:

- Enter the automation IP address of the system that needs to receive the PRINT_COMPLETE message,
- Set the automation port number of the system to which the message will be send,
- Enable "automation" by pressing the "disabled" button behind "Automation".
- Activating this command requires a reboot of the system. Switch off and back on after 10 seconds.

A few things to be aware about:

Once the automation feature has been activated, a TCP/IP server will be started in order to be able to send the message to the set IP etc. The controller will create a connection to the other IP address when the first message is about to be send. If there is no active IP address / port is found, the system will create an error message and the TCP/IP server is shut down. To restart the process, make sure the set IP address exists and is active. Toggle the automation option to try again.

The PRINT_COMPLETE string, send after each print when this function is activated, can be used by Nicelabel automation as an event on which defined actions can be executed. One of the most used actions is to get new data from a database, create a new label and send it to the printer. Effectively, the data to be printed on the products is synchronized with the printing process this way. One needs to be aware that after PRINT_COMPLETE has been received by the automation application, time is required to rebuild the e.g. new label, send it to the printer and for the printer to generate a bitmap for printing it on the product.

Part 1; selecting a label for printing over Ethernet.

As mentioned in the new features section, functionality has been added in order to be able to select a label for printing by sending a command over Ethernet. To make that possible, we have actually added two commands that perform the exact same operation, selecting a label for printing.

Select Label command standard version (Unicode)

The first command is in line with the default command protocol as is used in the X-series. The command provided is called SELECT_LABEL. The command must be used with 1 parameter, the location of the label. The label that is selected for printing needs to be in the controller.

The full command is as follows: SELECT_LABEL \NANDflash\QicControl\Labels\barcodes.X18

The first part is the command, SELECT_LABEL. This part is followed by a space character which is followed by the filename of the label complete with the full path. The text of this part must be Unicode encoded. Here a real example including the header and dummy CRC characters at the end (the "." Characters are actually <NULL> characters. The "." Is used to make it more readable and shorter):

```
^R.US0000095SELECT_LABEL<SP>\.N.A.N.D.f.l.a.s.h.\.Q.i.c.C.o.n.t.r.o.l.\.L.a.b.e.l.s.\.b.a.r.c.o.d.e.s...X.1.8.&%
```

This example shows the header indicating a payload of 95 bytes,

- <SP> is the space character (0x20),
- \.N.A.N.D.f.l.a.s.h.\.Q.i.c.C.o.n.t.r.o.l.\.L.a.b.e.l.s.\. is the path to the label location
- b.a.r.c.o.d.e.s...X.1.8. is the filename of the label
- &% are the two dummy CRC characters (could also be 0xFF)

The controller will respond with ^....0000002OK##

When the command has been send, the controller will select it for printing and show the selected label on the display in the "Live preview" area.

The extension used behind the label filename also needs to be added as one can see above. This is done because the controller can also contain labels which are created by an external application.

Extensions that one can come across are:

- X18, labels made on the Tsc20 controller with a X18 coding unit
- X54, labels made on the Tsc20 controller with a X54 coding unit
- X72, labels made on the Tsc20 controller with a X72 coding unit
- PRN, PNL, labels exported from Nicelabel using the windows driver for the X-series
- QDL, a legacy format that was used in the past with PC software QicDraw, which is obsolete.
- QDM, a multi label format containing labels that will be printed sequentially.

Select Label command standard version (ANSI)

The above command is the default command to select a label for printing over TCP/IP. However, there are cases that Unicode characters cannot be generated by the host or are difficult to generate by the host. To facilitate these circumstances, it is also possible to use the ANSI version of the command.

Here an example:

```
^R..S0000054SELECT_LABEL<SP>\NANDflash\QicControl\Labels\barcodes.X18&%
```

This example shows the header indicating a payload of 54 bytes,

- <SP> is the space character (0x20),
- \NANDflash\QicControl\Labels\ is the path to the label location
- barcodes.X18 is the filename of the label
- &% are the two dummy CRC characters (could also be 0xFF)

The controller will respond with ^...0000002OK##

The advantage is that the total length of the command is shorter (54 vs 95 bytes) and is easier to generate by the host. The disadvantage is that one cannot choose a file that has a filename made up out of Unicode characters.

Select Label command Escape version

Selecting a label for printing in an automated process is often done by PLC devices. Depending on the PLC and the integration level, the SELECT_LABEL command can be a bit long. For that reason, an alternative command has been added to the protocol which is a lot shorter. There are two things to think about when using this command:

1. The label name **MUST** consist of two integers in the range of 00-99, always two digits.
2. The labels **MUST** be located in the Label folder, not in any sub-folder (on the controller).
3. The label files need to have the extension of the coding unit connected, X18, X54 or X72. (e.g. 23.X18 or 04.X54 or 16.X72). Using label names with other extensions is not supported by this command

The command does not require a header nor does it require the two dummy CRC characters:

```
<ESC>xx<CR>
```

- <ESC>, the start of the command (0x1B, CTRL + [)
- xx, the label name without extension, always 2 digits 00-99
- <CR>, the end of the command (0x1D, CTRL + M)

Example: <ESC>03<CR> This will select the label named 03.X18 or 03.X54 or 03.X72 for printing.

The controller will respond with "Y<CR>". If the label does not exist, it will respond with "N<CR>"

Part 2; updating text fields inside the printed label over TCP/IP

There are more and more situations where the information, printed on the product, needs to change frequently. A very good way to make this possible is to use Nicelabel software in combination with the free printer driver for the X-series. Applications can be created which will send the correct data to the controller at all times.

Sending over a new label is one solution to update the information to be printed, but there are lot's of instances that require only a part of the printed information to be updated. This requires less data to be sent over to the controller. We have now added the functionality to update:

- Single line or multi-line text fields
- Contents of variables,
- Contents of barcodes (supported at the moment are GS1 128, Code 128, QR-code and Data Matrix),
- Current value of a counter,

In order to "address" the data in the label, each item in the label is identified by a "field number". The field number is assigned by the onboard label editor and is actually a sequential number that starts with "00". To make use of this feature, the labels need to be created on the controller or one needs to use the Nicelabel driver V5.3.00.7164 or higher to create labels which have the Field identifiers present.

Here too, we have implemented two commands to support field updating, just like with selecting a new label for printing.

Important to remember:

- Overwriting the contents of fields is not permanent. The FIELD contents will return to the default contents entered at design time. So, after a power toggle or selecting another label and selecting the current one again will print the label as it was designed.
- The exception is the counter item. As usual, the counter value is stored when the system is powered off and on the next boot, the counter will start where it left off. Selecting the same or another label will reset the counter(s)

Update text field command; standard version

Updating a text field using the standard protocol command UPDATE_TEXT_FIELD requires that the data is formatted as Unicode. Here an example of how to update field 00 inside a label:

```
^R...0000073UPDATE_TEXT_FIELD 00<CR><LF>UNICODE_TEXT=U.p.d.a.t.e. .t.e.k.s.t. .i.n. .v.a.r.&%
```

- ^R...0000073, the header showing a payload of 73 bytes
- UPDATE_TEXT_FIELD 00, the update command with FIELD number
- <CR><LF>, separator between command and actual contents. (<LF> is optional, but makes it more readable)
- UNICODE_TEXT=, this is always required so that the system knows that the following text is Unicode
- U.p.d.a.t.e. .t.e.k.s.t. .i.n. .v.a.r., the actual contents that will be place in FIELD 00 and printed
- &%, the dummy CRC characters. (can also be other characters)

The controller will respond with: ^....0000019UPDATE_TEXT_FIELD=0##

It is also possible to update a multi line text item using this command. The lines should be separated using the <ESC> (or 0x1B) character:

```
^R...0000073UPDATE_TEXT_FIELD 00<CR><LF>UNICODE_TEXT=L.i.n.e. .1.<ESC>L.i.n.e. .2<ESC>L.i.n.e. .3.&%
```

There are a few things to keep in mind using this command:

- The data needs to be formatted in Unicode
- When changing the label in regards to deleting and adding items (Fields), be aware that the onboard editor will renumber the fields. Use the option to show the field numbers to verify that the field numbers of the items that require updating are the same as used in external software that uses these commands.

Update text field command; Escape version

It is also possible to update a text field using the escape command version. Using the Esc command version, one can only use ASCII and extended ACSCII (0x20 - 0xAF) as data.

Here is an example of how to update text field 05 in a label:

```
<ESC>J00Update tekst in var<CR>
```

- <ESC> is the header (also known by CTRL+[or 0x1B)
- J is the command to update the field (ASCII "J" or 0x4A)
- "00" is the field number of the tekst that requires updating. The value needs to be between 00 and 99
- The closing character is carriage return (<CR> or CTR+M or 0x0D) (<CR><LF> is also accepted)

The controller will confirm by sending Y<CR> if the command is accepted or N<CR> if it is not.

There are a few things to keep in mind using this command:

- Only use ASCII between (0x20 - 0xAF) as data and do not use the <ESC> or <CR> characters in the data. <ESC> is used as separator character in multiple line text fields.
- After sending an update command, the label is updated. That is logical, but remember that using this command to update a lot of fields, will require the label to be updated after each single command. This will require time. Each update will also be confirmed by the controller. Make sure there is enough time between prints to be able to update the label completely.
- When changing the label in regards to deleting and adding items, be aware that the onboard editor will renumber the fields. Use the option to show the field numbers to verify that the field numbers of the items that require updating are the same as used in external software that uses these commands.

Appendix N Remapping inputs & outputs

This feature allows one to remap the mentioned input and output signals to a specific input or output pin on X03. The inputs for print request and product detect cannot be remapped. Remapping the general output is possible, but the default output can switch more power than the other outputs (default general error can switch 24V / 2A, the other outputs can switch 24V / 300mA).

These are the default settings:

Outputs:

X03-16A-7B Busy

X03-14A-5B Ink Out

X03-15A-6B Ink Low

X03-18A-9B General Error

Inputs

X03-19A-20B Inhibit

X03-13A-4B Trigger

Appendix O EC Declaration of conformity

(According to Annex II.A of the Machinery Directive 2006/42/EC)

We, BV Korthofah
 Lageweg 39
 2222 AG Katwijk ZH
 Nederland

declare under own responsibility that the product

Controller TsC20	(817807)
Controller TsC20-Duo	(818131)
Coding unit X18	(817752)
Coding unit X18+	(818157)
Coding unit X18si	(818227)
Coding unit X54	(817555)

to which this declaration relates is in conformity with the following standards or other normative documents

EN 61000-6-4 (2007) + A1 (2011)
EN 61000-3-2 (2014)
EN 61000-3-3 (2013)
EN 61000-6-2 (2005) + AC (2005)
EN 60950-1: 2006 + A1: 2010 + A11: 2009 + A12: 2011 + AC: 2011 + A2:2013

following the provisions of the

EMC Directive 2014/108/EU
Low Voltage Directive 2014/35/EU



M.P.J.J. de Groot, Directeur
November 30th 2015, Katwijk ZH, Nederland

bv korthofah

P.O. box: 3040
2222 AG, Katwijk
The Netherlands
